

NTIA

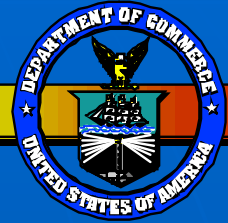

Effects of Pulsed Radar Waveforms on LTE (TDD) Receiver Performance

January 2014

Robert Sole: Rsole@ntia.doc.gov

Frank Sanders: FSanders@its.bldrdoc.gov

John Carroll: Jcarroll@its.bldrdoc.gov

National Telecommunications and Information Administration
1401 Constitution Avenue, NW
Washington, DC 20230

Background

- **FCC 3.5 GHz NPRM:**
Calls for effects of pulsed radar signals on performance of LTE receivers to be investigated
- **NTIA / ITS action to date:**
 - Designed tests to demonstrate the effects of pulsed radar signals on the performance of LTE receivers
 - Worked with a carrier to perform tests in realistic conditions
 - Published results in an NTIA Technical Report (TR-14-499)

Test Design and Execution

- Develop a matrix of test waveforms
 - Types of radar signals in and around 3550-3650 MHz
 - Not specifically matched to any particular operational radars
 - Span the parameter range of existing and future radar systems in band
 - 2 Gaussian noise waveforms
 - Other waveforms used in previous ECC tests
- Work with a carrier to perform the tests
 - Inject radar waveforms into TDD 4G LTE base station receiver
 - Measure
 - Data throughput (handset to base station)
 - Block error rate
 - Receiver noise

Radar Waveform Matrix

P0N (carrier wave) pulsed radar waveform parameters.			
Duty Cycle (%)	PRR = 1000/sec	PRR = 3000/sec	PRR = 10,000/sec
0.1	PW = 1 μ s P0N-1	PW = 0.33 μ s P0N-2	PW = 0.1 μ s P0N-3
1	PW = 10 μ s P0N-4	PW = 3.33 μ s P0N-5	PW = 1 μ s P0N-6
3	PW = 30 μ s P0N-7	PW = 10 μ s P0N-8	PW = 3 μ s P0N-9
10	PW = 100 μ s P0N-10	PW = 33.3 μ s P0N-11	PW = 10 μ s P0N-12

Q3N (swept-frequency) pulsed radar waveform parameters, 1 MHz/ μ s chirp.						
Duty Cycle (%)	Chirped Pulse Group 1		Chirped Pulse Group 2		Chirped Pulse Group 3	
	PW (μ s)	PRR (s^{-1})	PW (μ s)	PRR (s^{-1})	PW (μ s)	PRR (s^{-1})
1	10	1000 Q3N-1	1	10,000 Q3N-2	0.33	30,000 Q3N-3
10	100 \rightarrow 20	1000 \rightarrow 200 Q3N-4	10	10,000 Q3N-5	3.3	30,000 Q3N-6
20	200 \rightarrow 20	1000 \rightarrow 100 Q3N-7	20	10,000 Q3N-8	6.6	30,000 Q3N-9
30	300 \rightarrow 20	1000 \rightarrow 67 Q3N-10	30 \rightarrow 20	10,000 \rightarrow 6,667 Q3N-11	10	30,000 Q3N-12

Radar Waveforms (continued)

Additional special interference waveforms used in testing.			
Duty Cycle (%)	Waveform Names	PW (μ s)	PRR (pulses/sec)
0.4	ECC-1 — WFM-1	4	1000
3	ECC-2 — WFM-2	100	300
.05	TDWR — P0N-13	1	500

- Interference waveform design overall goal: vary interference duty cycle (DC) values in an approximately logarithmic progression
- Chirp bandwidth of Q3N (chirped) pulses was an additional degree of freedom in the waveform design. Solution:
 - Hold chirp frequency-sweeping rate constant at 1 MHz / μ s
 - Hold pulse widths to 20 μ s
 - Full explanation and documentation in NTIA Technical Report TR-14-499

Coupling Scenario

- Air search radars' beams look slightly above the local horizons, coupling most strongly into base stations
- Test bed needed to replicate this coupling scenario

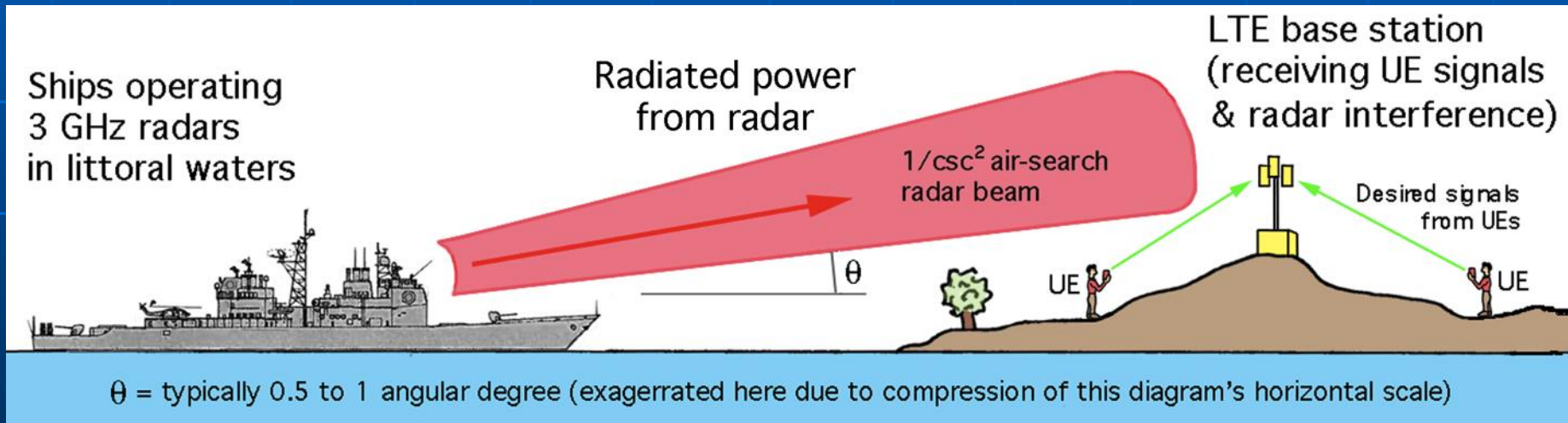

Test Bed High-Level Schematic

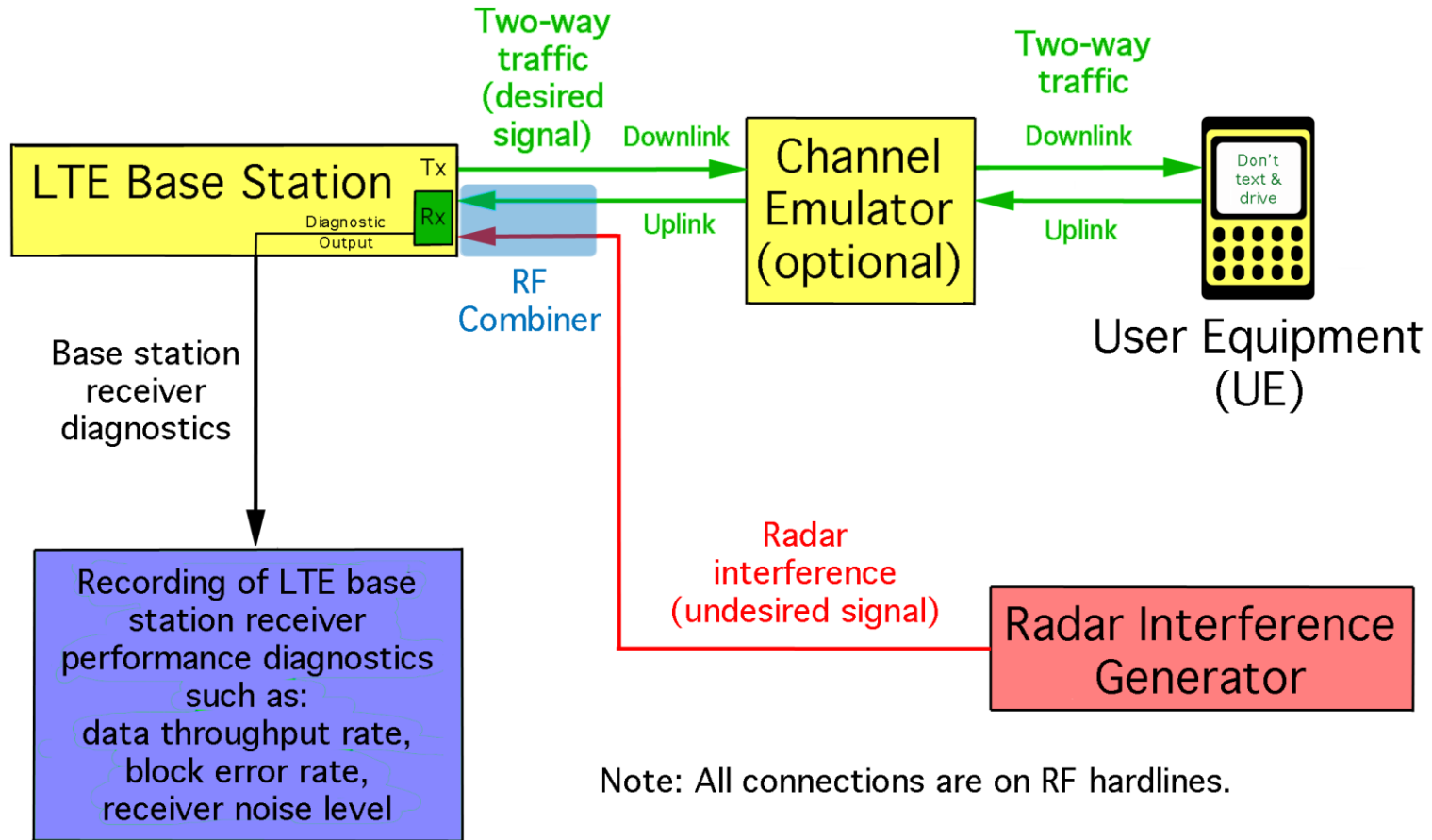

Test Bed Detailed Schematic

- Radar signals isolated to only appear on base station receiver side of LTE system
- Diagnostic software monitored, recorded once every second:
 - Data throughput
 - BLER
 - Receiver noise power
- 30 raw data points recorded per radar signal power level

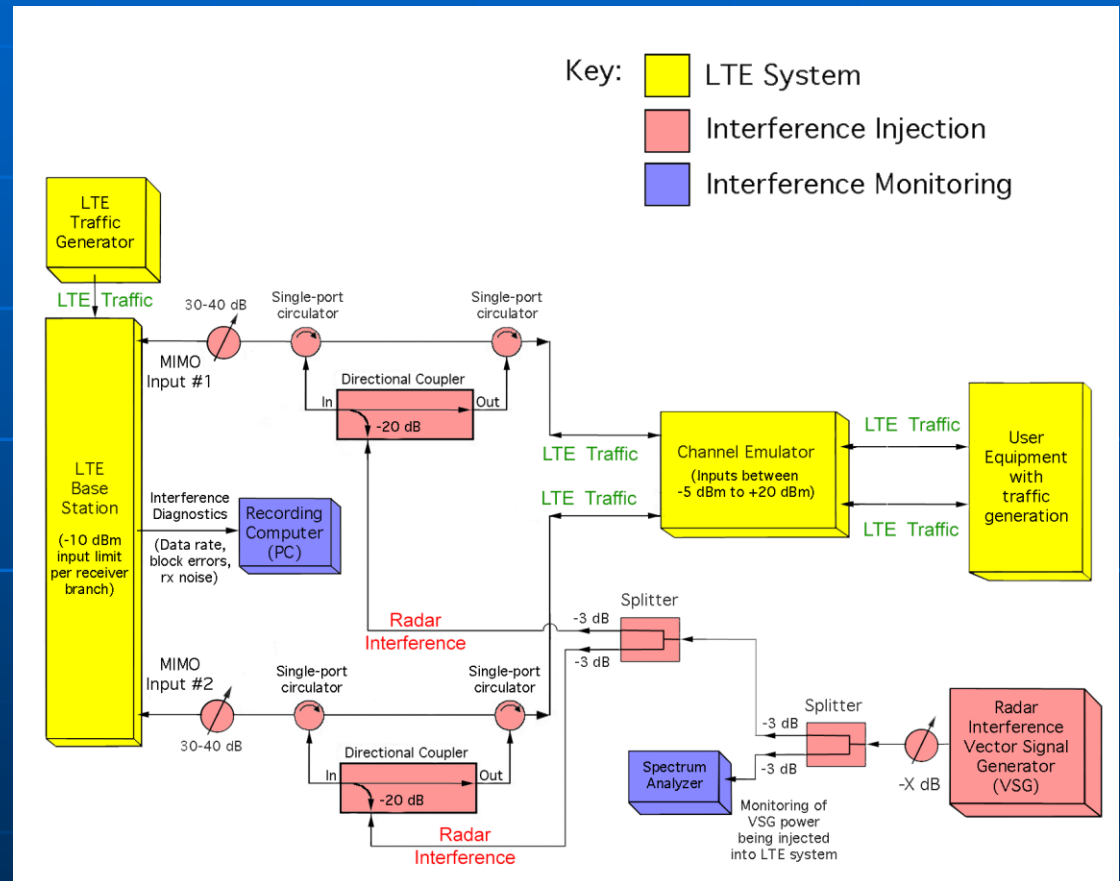

Baseline Test State

- Handset → base station nominal data rate 16 Mbit/s with no radar signal present
- Handset power at base station receiver input = -83 dBm/180 kHz resource block, held constant throughout
- Radar signals not synchronized to any TDD time slots
- Not tested:
 - Call initiation and call hand-off
 - LTE receiver saturation and burnout levels

Baseline Test Methodology

- Un-modulated radar signals on-tuned with center frequency of the 20 MHz wide LTE channel
 - Chirp center on-tuned with the LTE center frequency
 - Chirp was low to high frequency, linear
- Radar signal power
 - Initiated at a low level
 - Increased in 4 and 10 dB steps to close to maximum permissible power set by the carrier's conditions
 - Pulsed radar signal continuously applied at each power level
- Data post processed to produce figures showing data throughput, BLER, and receiver noise level as a function of $S/(I+N)$ for each radar waveform

Test Results

- NTIA is not specifying any particular acceptable radar signal power level for LTE receivers for the NPRM
- NTIA work has only shown effects that can happen in the presence of radar signals
 - Some radar waveforms had a drastic effect on the data throughput and caused the link to crash
 - Some radar waveforms had moderate effects
 - A few radar waveforms had no effect
 - NTIA has not investigated why or how the effects are different
- NTIA looks to the 4G LTE Industry to assist in analyzing the data and the results, and perhaps performing additional tests

Example $S/(I+N)$: Extreme Effect on Throughput Waveform P0N-10

PW = 100 μ s, PRR = 1,000/sec, DC = 10%

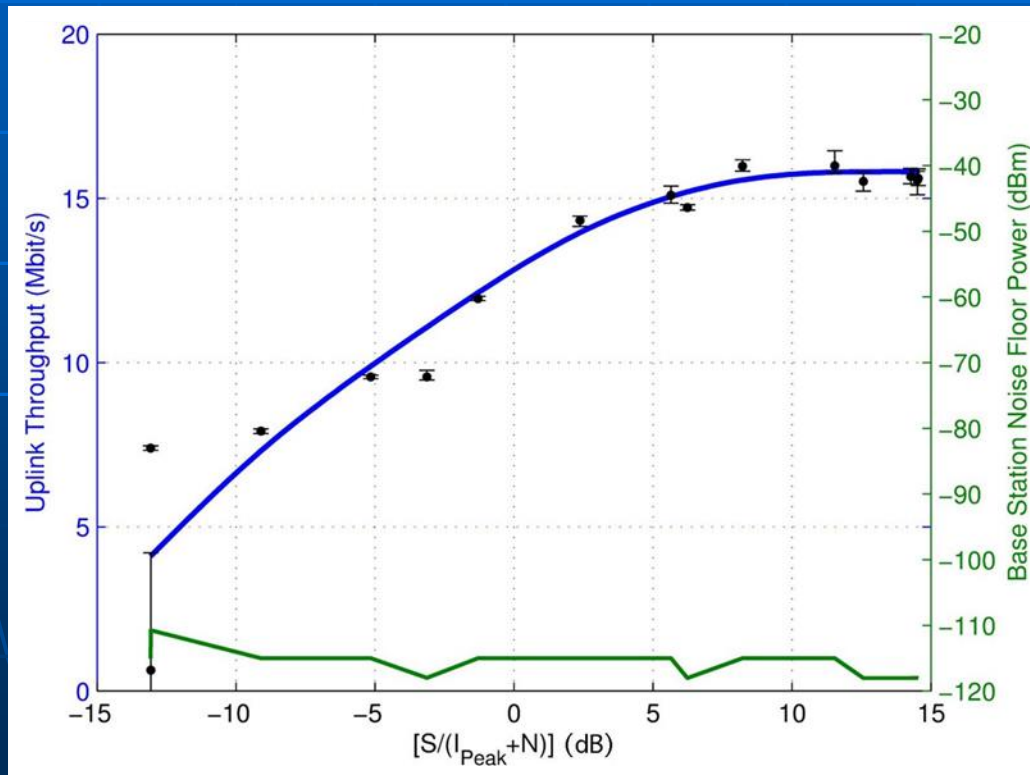

Example $S/(I+N)$: Extreme Effect on Throughput Waveform Q3N-5

PW = 10 μ s, PRR = 10,000/sec, DC = 10%

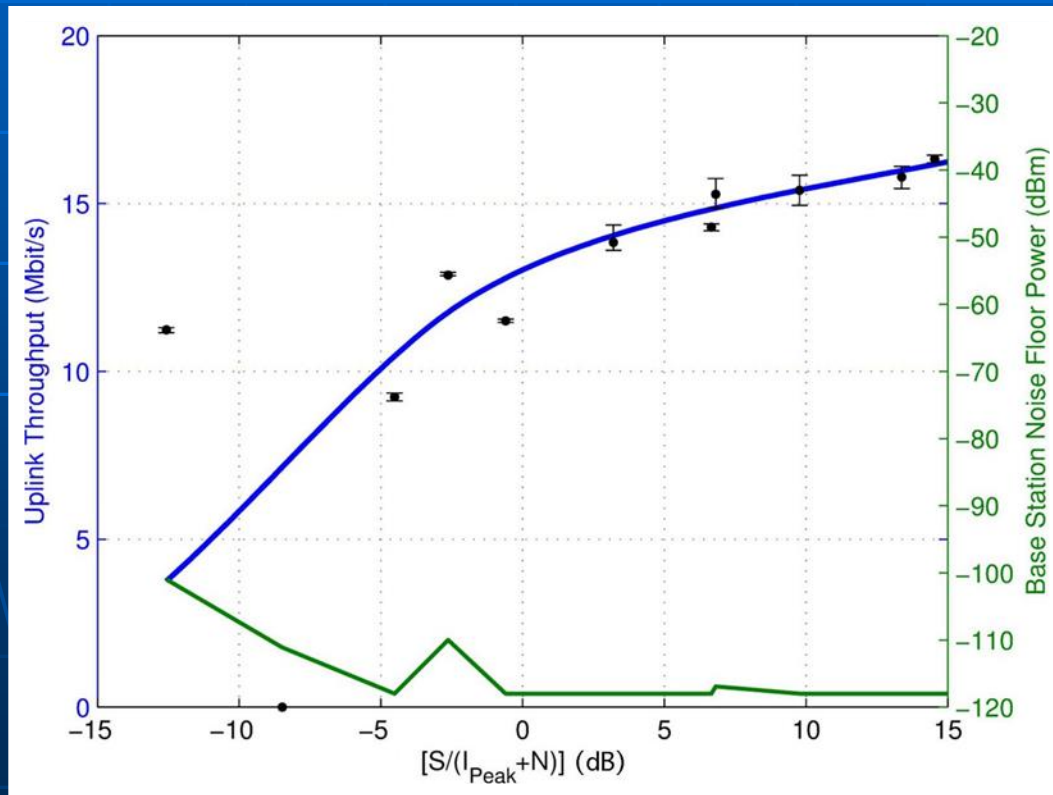

Example $S/(I+N)$: Moderate Effect on Throughput Waveform Q3N-6

PW = 3.3 μ s, PRR = 30,000/sec, DC = 10%

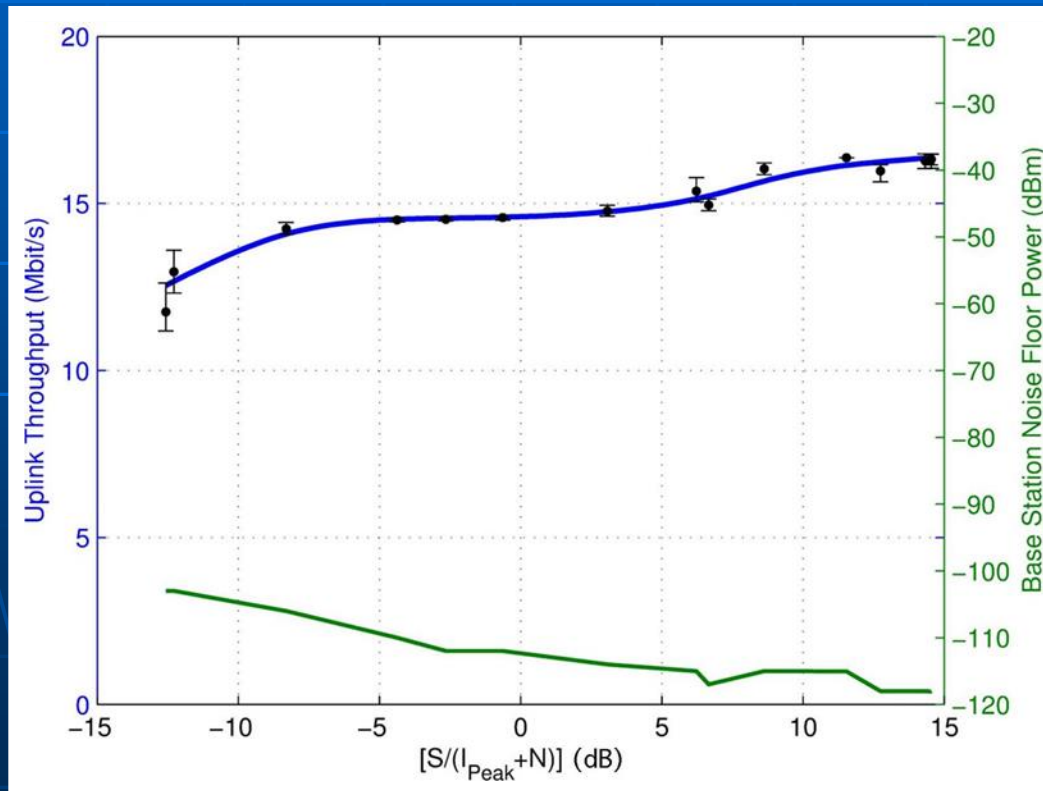

Example $S/(I+N)$: No Effect on Throughput Waveform Q3N-7

PW = 20 μ s, PRR = 100/sec
(equivalent to PW = 200 μ s, PRR = 1,000/sec), DC = 20%

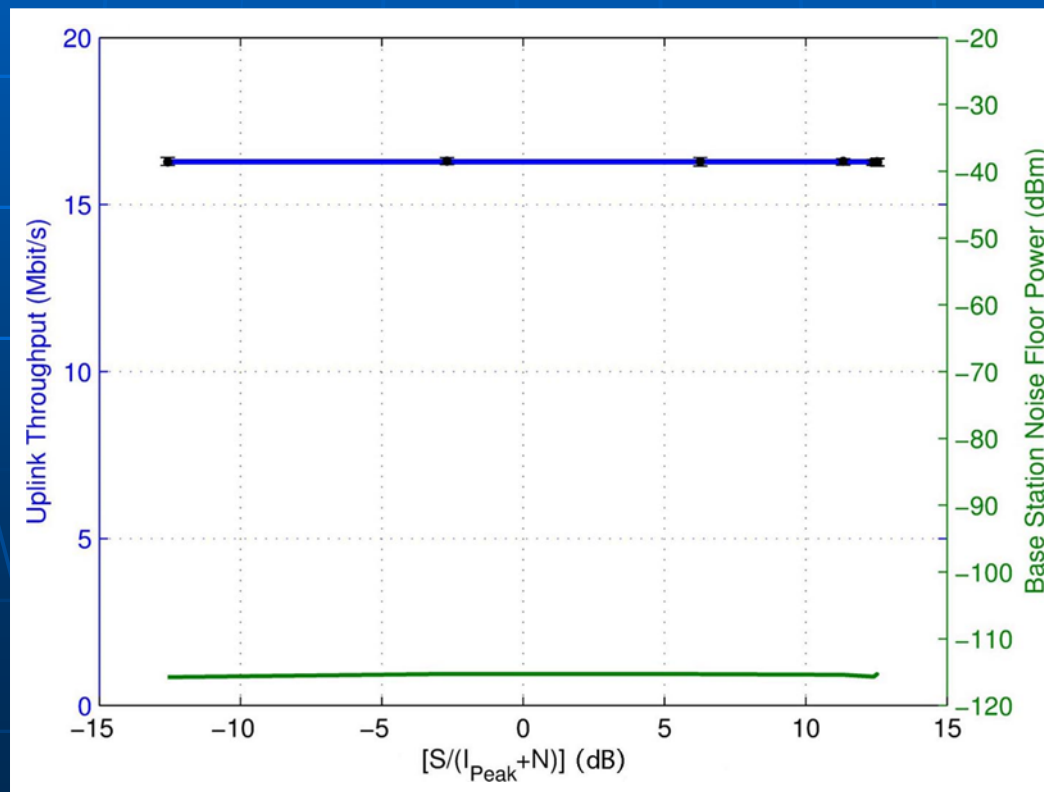

Future Work

NTIA looks forward to working with Industry on tests to:

- Test the authors' hypothesis that similar tests on a micro-cell LTE system will yield similar results
- Theoretical analysis to better understand why various radar interference waveforms have particular effects
- Increase understanding of LTE signal detection and processing
- Determine the non-linear effects of saturation and front-end overload from radar signals on LTE receivers
- Determine effects of a variety of radar beam-dwell periods on LTE base station receivers by testing with bursts of pulses to simulate radar beam scanning or antenna rotation

References

- [1] “Proposal to Create a Citizen’s Broadband Service in the 3550-3650 MHz Band”, FCC Docket No. 12-354. <http://www.fcc.gov/document/enabling-innovative-small-cell-use-35-ghz-band-nprm-order>
- [2] “An Assessment of the Near-Term Viability of Accommodating Wireless Broadband Systems in the 1675-1710 MHz, 1755-1780 MHz, 3500-3650 MHz, 4200-4220 MHz and 4380-4400 MHz Bands (President's Spectrum Plan Report)”, NTIA, U.S. Dept. of Commerce, Nov. 2010. <http://www.ntia.doc.gov/report/2010/assessment-near-term-viability-accommodating-wireless-broadband-systems-1675-1710-mhz-17>
- [3] CEPT ECC Report 174, “Compatibility Between the Mobile Service in the Band 2500-2690 MHz and the radiodetermination service in the band 2700-2900 MHz”, CEPT Electronic Communications Committee, Mar. 2012. <http://www.eroocdb.dk/docs/doc98/official/Pdf/ECCRep174.pdf>

References

- [4] "LTE radio link budgeting and RF planning", Section 2.1 (Typical parameter values). <https://sites.google.com/site/teencyclopedia/lte-radio-link-budgeting-and-rf-planning>
- [5] Sanders, F. H., R. L. Hinkle and B. J. Ramsey, "Measurement Procedures for the Radar Spectrum Engineering Criteria (RSEC)", NTIA Technical Report TR-05-420, U.S. Dept. of Commerce, Mar. 2005.
<http://www.its.bldrdoc.gov/publications/2450.aspx>
- [6] Sanders, F. H., R. L. Sole, J. E. Carroll, G. S. Secrest and T. Lynn Allmon, "Analysis and Resolution of RF Interference to Radars Operating in the Band 2700-2900 MHz from Broadband Communication Transmitters," NTIA Technical Report TR-13-490, U.S. Dept. of Commerce, Oct. 2012.
<http://www.its.bldrdoc.gov/publications/2684.aspx>
- [7] Sanders, F. H., "The Rabbit Ears Pulse Envelope Phenomenon in Off-Fundamental Detection of Pulsed Signals", NTIA Technical Report TR-12-487, U.S. Dept. of Commerce, Jul. 2012.
<http://www.its.bldrdoc.gov/publications/2678.aspx>

References

- [8] Sanders, F. H., R. L. Hinkle and B. J. Ramsey, "Analysis of Electromagnetic Compatibility Between Radar Stations and 4 GHz Earth Stations", NTIA Technical Report TR-94-313, U.S. Dept. of Commerce, Jul. 1994.
<http://www.its.bldrdoc.gov/publications/2340.aspx>
- [9] Sanders, F. H., Sole, R. L., J. E. Carroll, G. S. Secrest and T. L. Allmon, "Analysis and Resolution of RF Interference to Radars Operating in the Band 2700-2900 MHz from Broadband Communication Transmitters," NTIA Technical Report TR-13-490, Oct. 2012. Available:
<http://www.its.bldrdoc.gov/publications/2684.aspx>
- [10] Sanders, F. and R. Dalke, "Relationships Between Measured Power and Measurement Bandwidth for Frequency-Modulated (Chirped) Pulses," NTIA Technical Report TR-12-488, Aug. 2012. Available:
<http://www.its.bldrdoc.gov/publications/2680.aspx>
- [11] Sanders, F., J. E. Carroll, G. A. Sanders and R. L. Sole, "Effects of Radar Interference on LTE Base Station Receiver Performance," NTIA Technical Report TR-14-499, Dec. 2013. Available:
<http://www.its.bldrdoc.gov/publications/2742.aspx>

This Presentation

