

NTIA-REPORT-79-23

A COMPATIBILITY ANALYSIS OF SPREAD-SPECTRUM AND FM LAND MOBILE RADIO SYSTEMS

J. R. Juroshek



U.S. DEPARTMENT OF COMMERCE
Juanita M. Kreps, Secretary

Henry Geller, Assistant Secretary
for Communications and Information

August 1979



TABLE OF CONTENTS

	<u>Page</u>
LIST OF FIGURES.	v
LIST OF TABLES	vii
ABSTRACT	1
1. INTRODUCTION.	1
2. BACKGROUND.	2
3. SPREAD-SPECTRUM PERFORMANCE CALCULATIONS.	3
3.1 General Description.	3
3.2 Spread-Spectrum Performance in Gaussian Noise.	6
3.3 Spread-Spectrum Performance in Interference.	8
3.4 Performance in Multipath	11
4. FM PERFORMANCE CALCULATIONS	19
5. PROPAGATION MODELS.	22
6. SPREAD-SPECTRUM INTERFERENCE TO FM	25
7. FM INTERFERENCE TO SPREAD-SPECTRUM.	38
7.1 Single FM Interference	38
7.2 Multiple FM Interference	38
8. FM SQUELCH THRESHOLD.	52
9. ADDITIONAL FH SUPPRESSION	52
10. CONCLUSIONS	55
11. REFERENCES.	62
APPENDIX. COOPER-NETTLETON SYSTEM PARAMETERS.	65
1. System Description.	65
2. References.	69



LIST OF FIGURES

	<u>Page</u>
Figure 1.	Block diagram of direct sequence (a) and frequency hopping (b) systems. 4
Figure 2.	Spectra of SS systems operating in cw interference environments. Direct sequence system is shown in (a) while frequency hopping is shown in (b). 9
Figure 3.	Channel models used to evaluate effects of multipath . . 12
Figure 4.	Performance of a 2-phase, CPSK DS system over a channel composed of two equal strength specular paths. . . . 13
Figure 5.	Performance of a 2-phase, CPSK DS system over a channel composed of a direct specular path plus a diffuse, Rayleigh fading, reflected path. 15
Figure 6.	Channel impulse model used in performance calculations . 16
Figure 7.	Expected performance of an n = 32 frequency hop system for various channel conditions 18
Figure 8.	Signal-to-noise ratio out at an FM discriminator as a function of the signal-to-noise ratio into the discriminator for nonfading and Rayleigh fading channels. . 21
Figure 9.	Geometry involved in measuring d_{SS} and d_{FM} 27
Figure 10.	Separation distance d_{SS} versus d_{FM} to insure that S/I OUT > 20 dB. SS base interference to an FM base station, 150 MHz 28
Figure 11.	Separation distance d_{SS} versus d_{FM} to insure that S/I OUT > 20 dB. SS base interference to an FM mobile, or SS mobile interference to an FM base, 150 MHz 29
Figure 12.	Separation distance d_{SS} versus d_{FM} to insure that S/I OUT > 20 dB. SS base interference to an FM base, 900 MHz. 31
Figure 13.	Separation distance d_{SS} versus d_{FM} to insure that S/I OUT > 20 dB. SS base interference to an FM mobile, or SS mobile interference to an FM base, 900 MHz 32
Figure 14.	Separation distance d_{SS} versus d_{FM} that is required to insure that S/I OUT > 20 dB with a 1 MHz SS system at 150 MHz. 33
Figure 15.	Separation distance d_{SS} versus d_{FM} that is required to insure that S/I OUT > 20 dB with a 10 MHz SS system at 150 MHz. 34

	<u>Page</u>
Figure 16. Separation distance d_{SS} versus d_{FM} that is required to insure that $S/I_{OUT} > 20$ dB with a 1 MHz SS system at 900 MHz.	35
Figure 17. Separation distance d_{SS} versus d_{FM} that is required to insure that $S/I_{OUT} > 20$ dB with a 10 MHz SS system at 900 MHz.	36
Figure 18. Separation distance d_{FM} versus d_{SS} that is required to insure $10 \leq E_b/N_o \leq 20$ dB with $G_p = 30$ dB, 150 MHz . .	40
Figure 19. Separation distance d_{FM} versus d_{SS} that is required to insure $10 \leq E_b/N_o \leq 20$ dB, with $G_p = 40$ dB, 150 MHz. .	41
Figure 20. Separation distance d_{FM} versus d_{SS} that is required to insure $10 \leq E_b/N_o \leq 20$ dB, with $G_p = 30$ dB, 900 MHz. .	42
Figure 21. Separation distance d_{FM} versus d_{SS} that is required to insure $10 \leq E_b/N_o \leq 20$ dB, with $G_p = 40$ dB, 900 MHz. .	43
Figure 22. Geometry used in Monte-Carlo simulation.	46
Figure 23. Monte-Carlo simulation results for an SS system with $G_p = 30$ dB and E_b/N_o requirements of 20 dB at 150 MHz. .	48
Figure 24. Monte-Carlo simulation results for an SS system with $G_p = 30$ dB and $E_b/N_o = 10$ dB. The results also apply for a $G_p = 40$ dB system with E_b/N_o requirements of 20 dB at 150 MHz	49
Figure 25. Monte-Carlo simulation results for an SS system with $G_p = 40$ dB and E_b/N_o requirements of 10 dB at 150 MHz. .	50
Figure 26. Separation d_{th} that is required to avoid exceeding a -157 dBW squelch threshold on a $b_{IF} = 25$ kHz receiver. Frequency is 150 MHz	53
Figure 27. Separation d_{th} that is required to avoid exceeding a -157 dBW squelch threshold on a $b_{IF} = 25$ kHz receiver. Frequency is 900 MHz	54
Figure 28. Example of a frequency hopper with (a) all frequencies present and (b) a missed frequency	56
Figure 29. Separation distance d_{SS} versus d_{FM} that is required to insure $S/I_{OUT} > 20$ dB with a 1 MHz SS system at 150 MHz. Assumes additional 30 dB suppression due to FH pattern.	57

	<u>Page</u>
Figure 30. Separation distance d_{SS} versus d_{FM} that is required to insure $S/I_{OUT} > 20$ dB with a 10 MHz SS system at 150 MHz. Assumes additional 30 dB suppression due to FH pattern.	58
Figure A-1. Typical frequency-hopped, time-encoded signal	66
Figure A-2. Proposed decoder	68

LIST OF TABLES

Table 1. Constants Used in Propagation Formulas.	23
Table 2. Equations of Output Signal-to-Noise Ratio for an FM Base Station Receiving Interference from an SS Base Station	26
Table 3. Equations of Output Signal-to-Noise Ratio for an FM Base Station Receiving Interference from an SS Mobile or an FM Mobile Receiving Interference from an SS Base Station	26
Table 4. Summary of Separation Distance, d_{SS} , that is Required to Insure $S/I_{OUT} > 20$ dB (SS System Bandwidth is 1 MHz).	37
Table 5. Summary of Separation Distance, d_{SS} , that is Required to Insure $S/I_{OUT} > 20$ dB (SS System Bandwidth is 10 MHz)	37
Table 6. Equations of Output Signal-to-Noise Ratio, E_b/N_o , for an SS Base Station Receiving Interference from an FM Base Station.	39
Table 7. Equations of Output Signal-to-Noise Ratio, E_b/N_o , for an SS Base Station Receiving Interference from an FM Mobile or an SS Mobile Receiving Interference from an FM Base Station	39
Table 8. Summary of Separation Distance, d_{FM} , that is Required to Insure $10 \leq E_b/N_o \leq 20$ dB with $G_p = 30$ dB.	44
Table 9. Summary of Separation Distance, d_{FM} , that is Required to Insure $10 \leq E_b/N_o \leq 20$ dB with $G_p = 40$ dB.	44
Table 10. Summary of Monte Carlo Simulation Program where f_i is the Fraction of SS Mobiles Denied Access in the Circular Urban Model.	51

1. The first part of the document discusses the importance of maintaining accurate records of all transactions and activities. It emphasizes that this is crucial for ensuring transparency and accountability in the organization's operations.

2. The second part of the document outlines the various methods and tools used to collect and analyze data. It highlights the need for consistent and reliable data collection processes to support effective decision-making.

3. The third part of the document focuses on the role of technology in data management and analysis. It discusses how modern software solutions can streamline data collection, storage, and reporting, thereby improving efficiency and accuracy.

4. The fourth part of the document addresses the challenges associated with data management, such as data quality, security, and privacy. It provides strategies to mitigate these risks and ensure that data is used responsibly and ethically.

5. The fifth part of the document concludes by summarizing the key findings and recommendations. It stresses the importance of ongoing monitoring and evaluation to ensure that data management practices remain effective and aligned with the organization's goals.

6. The sixth part of the document provides a detailed overview of the data collection process, including the identification of data sources, the design of data collection instruments, and the implementation of data collection procedures.

7. The seventh part of the document discusses the various methods used for data analysis, such as descriptive statistics, inferential statistics, and regression analysis. It explains how these methods are used to interpret the data and draw meaningful conclusions.

8. The eighth part of the document focuses on the importance of data visualization in presenting complex information in a clear and concise manner. It discusses various visualization techniques, such as bar charts, line graphs, and pie charts.

9. The ninth part of the document addresses the ethical considerations surrounding data management and analysis. It discusses the need for transparency, informed consent, and the protection of individual privacy and data security.

10. The tenth part of the document provides a summary of the key points discussed throughout the document. It reiterates the importance of data management and analysis in supporting organizational success and decision-making.

11. The eleventh part of the document discusses the role of data in strategic planning and decision-making. It explains how data can be used to identify trends, opportunities, and risks, and to inform the development of strategic initiatives.

12. The twelfth part of the document focuses on the importance of data literacy for all employees. It discusses the need for training and education to ensure that employees are equipped with the skills and knowledge to effectively use data in their work.

13. The thirteenth part of the document addresses the challenges of data integration and interoperability. It discusses the need for standardized data formats and protocols to ensure that data from different systems can be easily shared and analyzed together.

14. The fourteenth part of the document discusses the role of data in customer relationship management (CRM). It explains how data can be used to understand customer behavior, preferences, and needs, and to tailor marketing and sales efforts accordingly.

15. The fifteenth part of the document provides a final summary and conclusion. It emphasizes the importance of data management and analysis as a core component of organizational success and decision-making.

A COMPATIBILITY ANALYSIS OF SPREAD-SPECTRUM AND FM LAND MOBILE RADIO SYSTEMS

John R. Juroshek^{*}

The possibility of overlaying a spread-spectrum system into frequency bands containing conventional FM land-mobile systems is examined. Overlaying here is interpreted as meaning the unrestricted operation of spread-spectrum and FM mobiles throughout the same service area and on the same frequency. The report assumes conventional spread-spectrum and FM systems where a single base serves a large urban area. The small cell narrow coverage concept is not discussed. A theoretical compatibility study is described that concludes that significant interference would result to existing FM systems. This conclusion assumes spread-spectrum transmitter powers comparable to existing FM systems. The report considers land-mobile operating frequencies of 150 and 900 MHz.

The study also examines the reverse problem of interference from FM to spread spectrum. Curves are prepared showing separation requirement for various channel multipath conditions. A computer simulation program is also described that simulates the operation of a spread-spectrum system in a multiple FM interferer environment. The conclusions are that an overlaid spread-spectrum system also would receive significant interference.

The report also describes a frequency hopping, spread-spectrum system that is programmed to miss those FM channels in use at a given locality. The advantages obtained with this technique are briefly discussed.

Key words: frequency modulation; interference; land mobile radio; multipath; propagation; spread spectrum

1. INTRODUCTION

The issues of whether or not to allow the use of wideband, spread-spectrum (SS) systems in an already crowded frequency spectrum are numerous and complex. One can undoubtedly find a number of arguments both for and against the wisdom of such a decision. To compound the situation, the arguments become more confusing when one is considering the urban land-mobile environment where spectrum is scarce and propagation conditions are poor.

* The author is with the U.S. Department of Commerce, National Telecommunications and Information Administration, Institute for Telecommunication Sciences, Boulder, Colorado 80303.

This report will attempt to shed some light on at least one facet of the problem; namely, the possibility of spectrum sharing between a spread-spectrum land mobile system and a conventional frequency-modulated (FM), land-mobile system. Specific attention will be given to the problems involved in the overlaying of a new spread-spectrum system into the frequency bands already occupied by existing FM systems. Overlaying here is interpreted as the unrestricted operation of SS and FM land-mobile systems in the same service area and on the same frequency. The scope of this report has been limited to only voice transmission. However, some of the results are applicable to both data and voice as will be shown later.

2. BACKGROUND

The basic principle behind the success of a spread-spectrum system is that the transmitted signal is spread over a frequency band much wider than the information bandwidth of the signal being sent. This increased bandwidth buys a number of advantages as well as, unfortunately, some disadvantages. The major advantage, and probably the most compelling reason behind the development of spread-spectrum systems, is a reduced vulnerability to jamming and interference. It can be easily shown (Dixon, 1976) that the output signal-to-noise ratio of a spread-spectrum system in an interference or jammer dominated environment is

$$\frac{S}{N} \text{ OUT} = \frac{S}{I} \text{ IN} + G_p \quad \text{dB} \quad , \quad (1)$$

where $(S/I) \text{ IN}$ is the ratio in decibels of signal-to-interference power at the input to the receiver and G_p is the processing gain given by

$$G_p = 10 \log \frac{b_{\text{RF}}}{b_{\text{INF}}} \quad \text{dB} \quad . \quad (2)$$

Throughout this report a convention will be used where quantities such as G_p will be shown with upper case letters if it is in decibels and lower case if it is in numeric form. Here $b_{\text{RF}}/b_{\text{INF}}$ represents the ratio of the system's transmission bandwidth to information bandwidth. Thus, with $b_{\text{RF}} = 1 \text{ MHz}$ and $b_{\text{INF}} = 10 \text{ kHz}$, the value of the processing gain will be $G_p = 20 \text{ dB}$, which

means that the spread-spectrum system can have an output signal-to-noise ratio greater than 0 dB even though S/I at the input to the receiver is less than 0 dB.

One must not assume, however, that a spread spectrum system offers any improvement over a narrowband system operating in white Gaussian noise. The output signal-to-noise ratio for an SS system in Gaussian noise can be shown to be

$$\frac{S}{N} \text{ OUT} = 10 \log \left(\frac{s}{b_{\text{INF}} n_o} \right) \text{ dB} , \quad (3)$$

where s/n_o is the ratio of input signal power to noise power density and b_{INF} is the information bandwidth. This means that the output signal-to-noise ratio for white Gaussian noise is independent of the rf bandwidth or processing gain.

These concepts can be generalized to some extent. Generally speaking, a wideband, spread-spectrum system will perform better than a narrowband system in an interference environment where the spectral bandwidth of the interference is much less than b_{RF} . If the spectral bandwidth of the interference is greater than b_{RF} , the performance advantage of a wideband system over a narrowband system is generally minimal since the increase in performance due to processing gain is offset by the increase in interference power due to the wider bandwidth receiver. The word "generally" must be emphasized here since secondary considerations do exist. For example, the performance of most spread-spectrum systems is determined by the average power in the interference signal and thus is fairly insensitive to the interferer's peak power characteristics. This means a spread-spectrum system can potentially offer an advantage in a wideband pulsed type of interference where the average power is much less than the peak.

3. SPREAD-SPECTRUM PERFORMANCE CALCULATIONS

3.1 General Description

Spectrum spreading can be accomplished by many different methods. Figure 1 shows block diagrams of two common methods that will be considered in this report. These are spectrum spreading by direct sequence (DS) techniques as shown in Figure 1(a) and frequency hopping (FH) as shown in Figure 1(b).

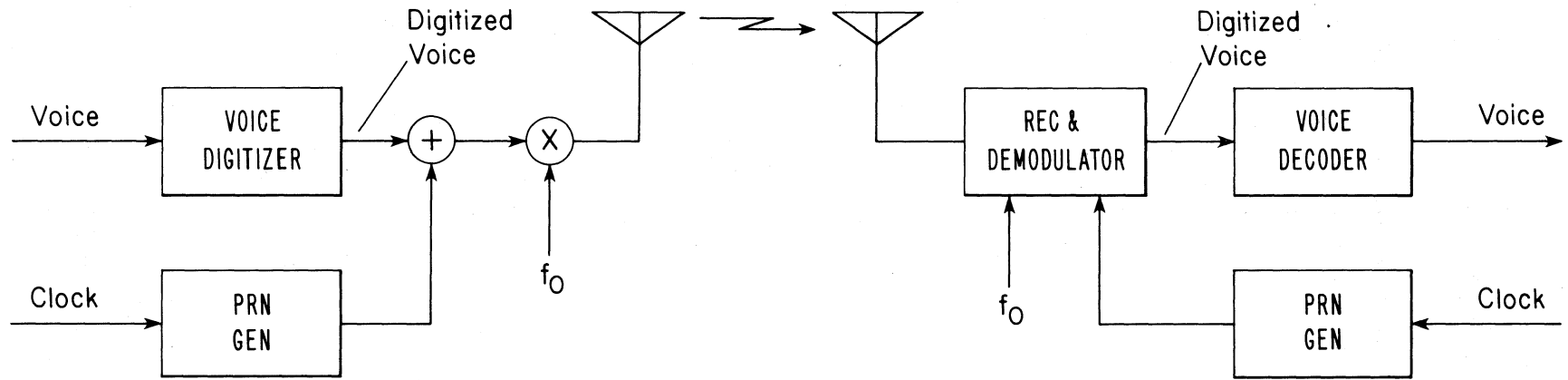

(a)

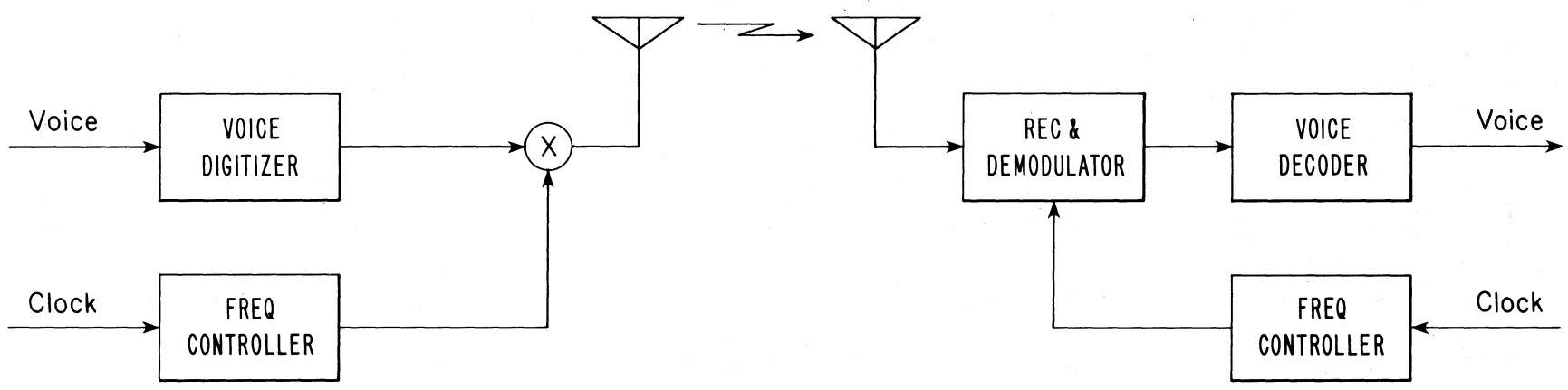

(b)

Figure 1. Block diagram of direct sequence (a) and frequency hopping (b) systems.

Examples of other techniques that exist but are not being examined in this report are chirp modulation, time hopping, and hybrid techniques composed of combinations of the preceding techniques (Dixon, 1976).

Direct sequence spectrum spreading is accomplished by modulo-2 addition of a high rate (typically 1 Mbps or greater) pseudo-random (PRN) code to a slower (50 kHz or less) digitized voice signal. The resulting wideband binary signal is then converted into a bi-phase, phase-shift-keyed signal for transmission over the channel.

Frequency hopping, in contrast, spreads the spectrum by changing the frequency in discrete hops according to some predetermined pseudo-random pattern. The output of a frequency hopper is essentially a narrowband, bi-phase, phase-shift-keyed signal whose center frequency is changing in discrete, pseudo-random hops. The advantages of frequency hoppers are generally said to be in the reduced requirements for time synchronization. With direct sequence, the smallest element of interest is the PRN code element, often called a chip, which for a 10 MHz system is 100 ns. Conversely, the shortest element of a frequency hopper is the time duration between hops which can be as great as 100 μ s for a similar 10 MHz system. Unfortunately, the synchronization advantage leads to a related disadvantage since the performance of a frequency hopper in multipath is usually poorer than that of a direct sequence system. The performance of each of these systems in multipath will be discussed in Section 3.4.

Spread-spectrum systems have other advantages in addition to their ability to combat interference and jamming. Some of the advantages are as follows:

- (a) Relatively low power density: Power spectral density of the radiated signal is generally lower than for narrowband systems. This means the potential for interference to a narrowband system is less.
- (b) Resistance to multipath: A spread-spectrum system exhibits an inherent resistance to multipath. Sufficiently delayed multipath signals are transformed into noise in the decorrelation process.
- (c) Security: The system has security advantages because the low power spectral density characteristics make the signal

harder to find. Also, the spectrum spreading process can provide security, if designed properly, since the user must know the spreading code, or process, before signal detection can be attempted.

- (d) Ranging: The wide bandwidth of the transmitted signal enables the resolution of time differences to a precision that is necessary for ranging.

Some of the disadvantages are:

- (a) Complexity: The complexity of the system results in more sophisticated and costly equipment.
- (b) Synchronization: Synchronization and acquisition problems are often a major factor in system design and system performance, particularly under conditions where multipath exists.
- (c) Capture effects: A spread-spectrum system can always be captured by a sufficiently strong interfering signal.
- (d) Bandwidth requirements: A spread-spectrum system requires a considerable amount of spectrum. Implementation of systems with bandwidth expansion factors much below 100 is generally considered impractical.

Although the discussions in this report are primarily directed toward an SS system carrying voice traffic, the results are also generally applicable to an SS system carrying data. In other words, the results are generally independent of whether the information being transmitted is digitized voice or data provided the bit rates involved are the same.

3.2 Spread-Spectrum Performance in Gaussian Noise

In estimating the performance of the DS and FH systems, we shall assume that the receiver-decorrelators, as shown in Figure 1, are optimum matched filters. This will probably not be the case in actual practice since a sub-optimum detection scheme, which is better adapted to the harsh land-mobile environment will probably be used. Nevertheless, the errors involved are minor considering the other unknowns and generalized nature of this report.

Given the assumption of matched filters, the ratio of signal power to noise power at the output of the SS decorrelator is

$$\frac{s}{n} \text{ OUT} = \frac{e_s}{n_o} \cdot \frac{1}{t_s b_{\text{INF}}} , \quad (4)$$

where e_s is the energy of the transmitted waveform, t_s is the waveform time duration, n_o is the Gaussian noise power density, and b_{INF} is the bandwidth of the matched filter. The quantity t_s can also be thought of as the period available to the decision device for viewing the received waveform. At the end of this period, the device must decide as to the status of the received waveform and output the corresponding bits.

The ratio of signal power to noise power at the input to the correlator can be shown to be

$$\frac{s}{n} \text{ IN} = \frac{s}{n_o b_{\text{RF}}} , \quad (5)$$

where b_{RF} is the rf bandwidth of the receiver. Thus, the ratio

$$\frac{\frac{s}{n} \text{ OUT}}{\frac{s}{n} \text{ IN}} = \frac{b_{\text{RF}}}{b_{\text{INF}}} = g_p \quad (6)$$

is defined as processing gain g_p . One can also show that, for a matched filter,

$$b_{\text{INF}} \approx \frac{1}{t_s} , \quad (7)$$

which means that

$$\frac{s}{n} \text{ OUT} \approx \frac{e_s}{n_o} . \quad (8)$$

As noted previously, the decision device can output more than one information bit for each decision. If k information bits are obtained for each decision, the system is said to be using M -ary transmission, where

$$k = \log_2 M \quad (9)$$

and M is the number of waveforms that must be recognized by the decision device. For binary encoded transmission, $M = 2$ and $k = 1$. The ratio of energy-per-bit e_b to noise power density n_o is also useful and is defined as

$$\frac{e_b}{n_o} = \frac{e_s}{n_o \cdot k} \quad (10)$$

3.3 Spread-Spectrum Performance in Interference

Unfortunately, the simple tractable solutions common to Gaussian noise disappear when one considers performance in interference. The reason for this is due, at least in part, to the fact that the interferer's statistics are either unknown or mathematically complex. Thus, in the following material, we will be forced to make some estimates based on current SS systems.

One of the facts that is often overlooked is that an optimum matched filter receiver is optimized only for additive Gaussian noise. This means that its performance can be surprisingly poor in interference. This is particularly true for the frequency-hopping receiver where interference can cause significant problems if the receiver has not been properly engineered with interference in mind.

The interference environment of concern here is one composed of multiple, narrowband, FM, land-mobile signals whose spectra are typically about 10 kHz wide. For all practical purposes, the FM signal will appear to be cw interference to the much wider bandwidth, spread-spectrum system. If the spread-spectrum system has an rf bandwidth of 10 MHz and the FM channel assignments are 25 kHz, one could expect a maximum of $10/.025 = 400$ such interferers within the receivers operating passband. Practically, of course, only a relatively small fraction of these interferers will be active at any given instant in time.

Figure 2 shows how the DS and FH receivers handle interference. The response of the DS receiver is shown in Figure 2(a), where the various spectra are given before and after multiplication in the receiver by the local PRN reference signal. As can be seen, the desired signal is collapsed into the original narrowband information signal of bandwidth b_{INF} , while the interference is spread in frequency into a noise-like signal of bandwidth

Before Multiplication by
Local Reference Signal

After Multiplication

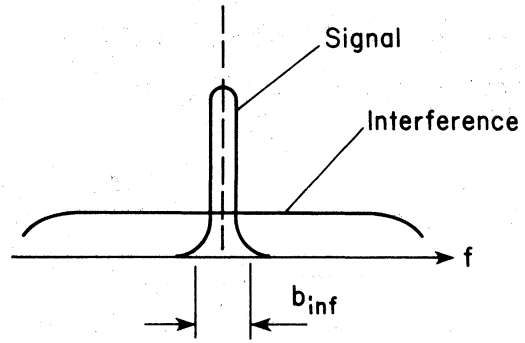
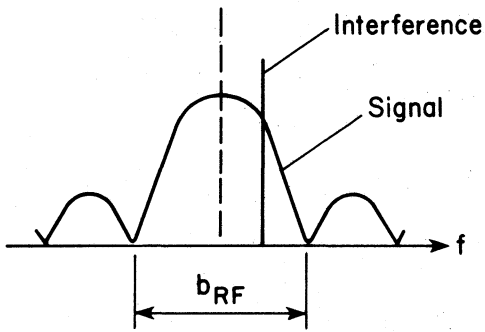

(a)

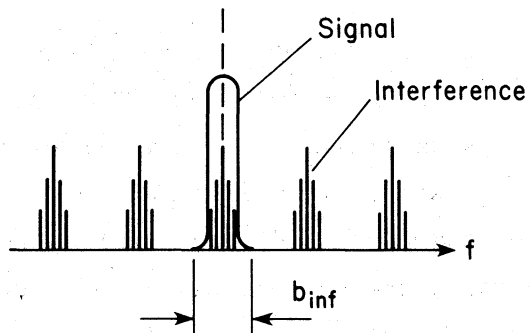
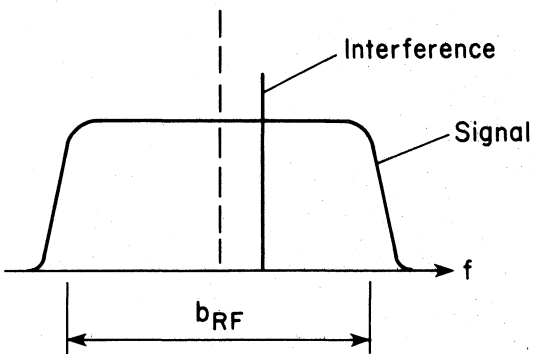

(b)

Figure 2. Spectra of SS systems operating in cw interference environments. Direct sequence system is shown in (a) while frequency hopping is shown in (b).

approximately equal to b_{RF} . These signals are then filtered to a bandwidth b_{INF} , which means that the interference is transformed into Gaussian noise and reduced in power by the factor

$$10 \log \frac{b_{INF}}{b_{RF}} = -G_p \quad \text{dB} \quad , \quad (11)$$

Since the signal power is essentially unchanged by the decorrelator, the output signal-to-interference ratio is

$$\frac{S}{N} \text{ OUT} = \frac{S}{I} \text{ IN} + G_p \quad \text{dB} \quad , \quad (12)$$

as originally described in (1). However, in order to remove the data rate parameter, most technical literature avoids using $\frac{S}{N} \text{ OUT}$, but instead measures performance in terms of E_s/N_o or E_b/N_o . For the binary case ($k = 1$), expressions (8), (10), and (12) can be combined to yield

$$\frac{E_b}{N_o} = \frac{S}{I} \text{ IN} + G_p \quad \text{db} \quad . \quad (13)$$

The effect of cw interference on a frequency hopper is somewhat different as shown in Figure 2(b). As can be seen, the FH decorrelator "maps" the cw interferer to a new frequency at each hop of the local reference signal. Exactly what frequency and how many frequencies the interfering signal can be mapped to depends on the design of the PRN frequency hopping sequence. In fact, one can visualize the case where the frequency increments are sufficiently close to each other that the interference spectra would be continuous. In other words, the FH system would remap the cw interference into a continuous spectra spread through a frequency band of b_{RF} . The interference spectra out of the decorrelator would thus be identical for the FH and DS systems, which means that (12) and (13) apply to both types of systems.

So far the discussion on the performance of SS systems in interference has been idealized, and has concluded that the cw interference power out of the decorrelator will be reduced by the factor G_p . Unfortunately, there are practical design considerations that prevent one from achieving this limit. This is particularly true for the FH system where numerous articles have appeared describing why the actual improvement can be less than predicted (Pettit, 1977; Kullstam, 1977; and Davies, 1973). The article by Pettit shows

that the actual processing gain for a $G_p = 27$ dB FH system can range anywhere from 6 to 27 dB. One of the major problems that must be overcome in an FH system is that, if there are m available frequencies for hopping to, a cw interferer effectively destroys $1/m$ of the available spectrum. Thus, ideally one would like m to be as large as possible. Digital encoding is also recommended to insure that correct reception will be achieved even though the 1 out of N frequencies has been disabled.

Equations (12) and (13) also apply if there are multiple independent interferers on different frequencies. The value for $(S/I)_{IN}$ now becomes the ratio of signal power to total received power from all interferers.

3.4 Performance in Multipath

The performance of an SS system in multipath can probably best be understood by looking at specific examples. Unfortunately, examples dedicated to the urban multipath environment are almost nonexistent. Calculations do exist, however, for some elementary channels shown in Figure 3.

The first example is the DS system operating in a channel composed of two specular paths. The signal power received over each path is assumed to be equal, with a difference in time of arrival between the two signals $\Delta\tau$. It is also assumed that each of the paths adds a random phase perturbation to the signal and that the phase perturbation is uncorrelated between paths. This means that fading will still occur even as $\Delta\tau$ approaches zero. Estimates of the probability of a bit error P_e for this situation have been derived by Cahn (1973) and are shown in part in Figure 4. Four curves are shown in this figure for different values of differential time delay $\Delta\tau$, where $\Delta\tau$ is expressed relative to the PRN chip element duration t_c (a 1 MHz SS system would have $t_c \approx 1 \mu\text{s}$). As can be seen, the worst case occurs when the time delay between two paths is such that $\Delta\tau = 0$, which is an unlikely condition in nature. Next note that, unlike conventional narrowband systems, the performance improves with increasing time delay until eventually, when $\Delta\tau > t_c$, the system performs as though there were no multipath at all. The reason for this is that a signal delayed by more than t_c is essentially uncorrelated from the direct signal. Therefore, this signal is treated as uncorrelated interference in the decorrelation process, which means that its effective power is reduced by the factor G_p . Thus the performance of a DS

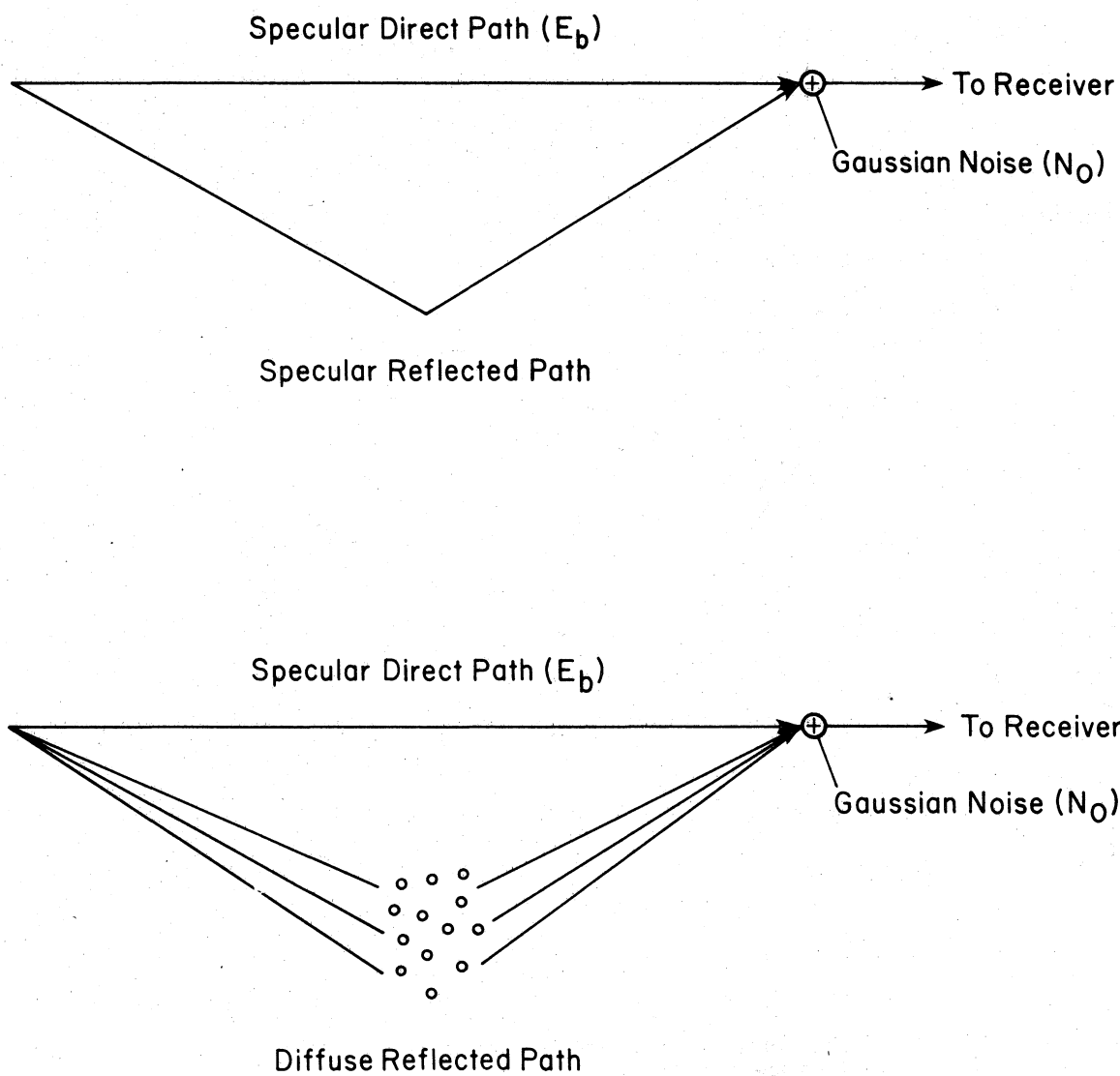

Figure 3. Channel models used to evaluate effects of multipath.

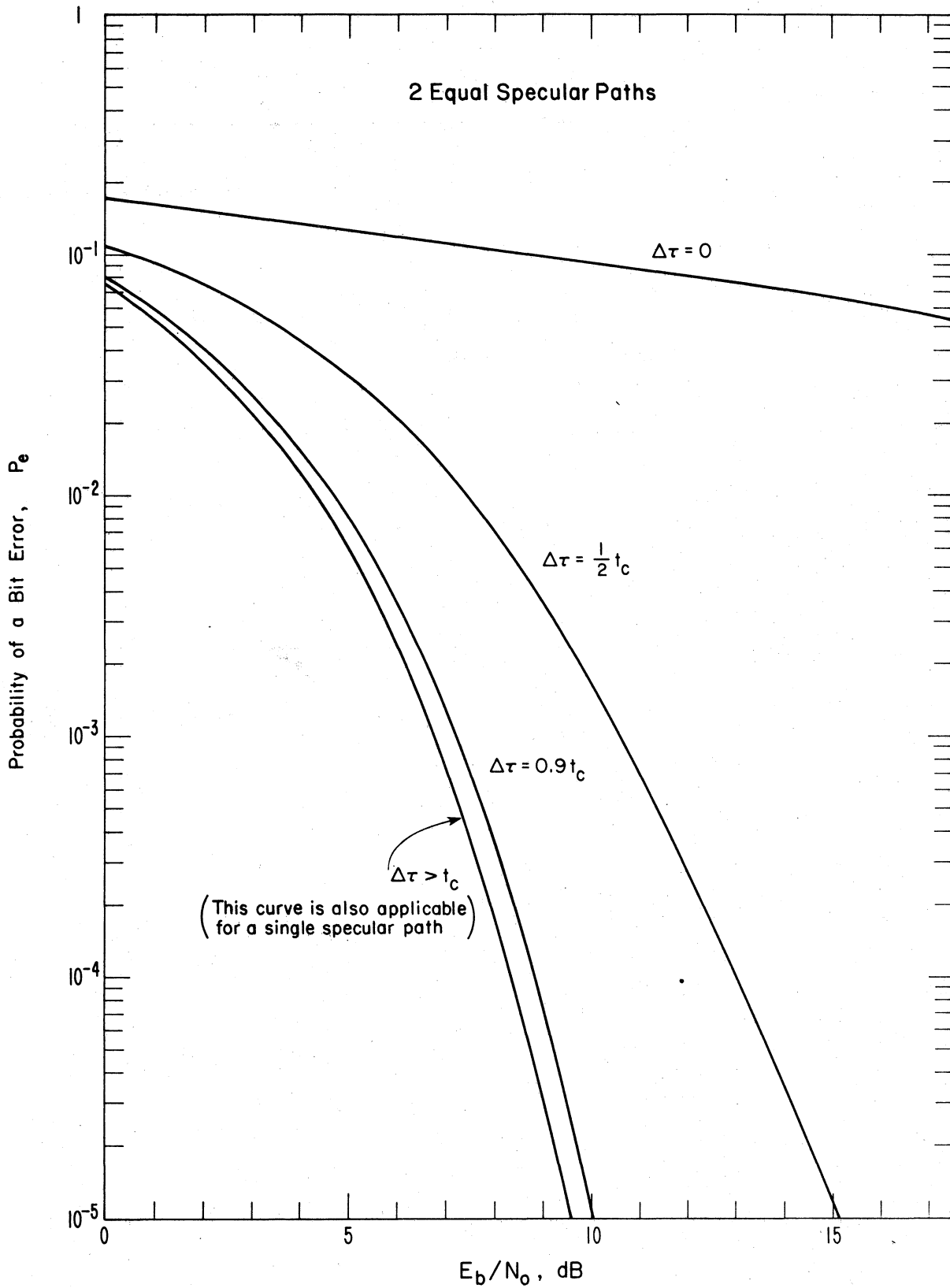

Figure 4. Performance of a 2-phase, CPSK DS system over a channel composed of two equal strength specular paths.

system is generally unaffected by multipath components delayed by more than t_c . This, of course, is a simplified explanation as other considerations exist, particularly in the area of maintaining synchronization.

A similar channel, for which the performance of the DS system is known, is one in which the reflected path is a diffuse or scatter type of reflection (Cline, 1973). The probability of a bit error as a function of E_b/N_o in this situation is shown in Figure 5. The curves in this figure are parametric, in the ratio P_d/P_R , which is the power in the direct path relative to the power in the indirect path. For this case, the worst performance occurs when the channel is all diffuse; however, the performance rapidly improves with the addition of a specular-direct path. These calculations assume that all multipath components have differential time delays such that $\Delta\tau \leq t_c$.

It should be pointed out that the curves in Figures 4 and 5 that are shown for specular-only propagation are also applicable for conventional narrowband CPSK digital systems. In other words, the E_b/N_o requirements for a DS system are identical to those for conventional CPSK on a nonfading, Gaussian, additive-noise, propagation channel. The performance however is significantly different on fading channels with multipath or any propagation channel with narrowband interference.

The last example is an FH system that is designed specifically for the land-mobile environment. This system, as proposed by Cooper and Nettleton (1976), uses a M-ary time encoded waveform that frequency hops over m different frequencies. A detailed description of this system is given in the Appendix.

The performance of this system has been computed for the channel containing both a specular and fading component as shown in Figure 3(b). However, unlike the previous calculations, the multipath is no longer restricted to the case $\Delta\tau < t_c$. Figure 6 shows the channel impulse model that is used in these calculations. It contains a specular component due to the direct path plus a diffuse component whose energy versus time-of-arrival is exponentially decaying. The correlation function of this channel as a function of frequency offset Δf is given as

$$C(\Delta f) = a + \frac{(1 - a)}{1 + \phi(\Delta f)^2} \quad (14)$$

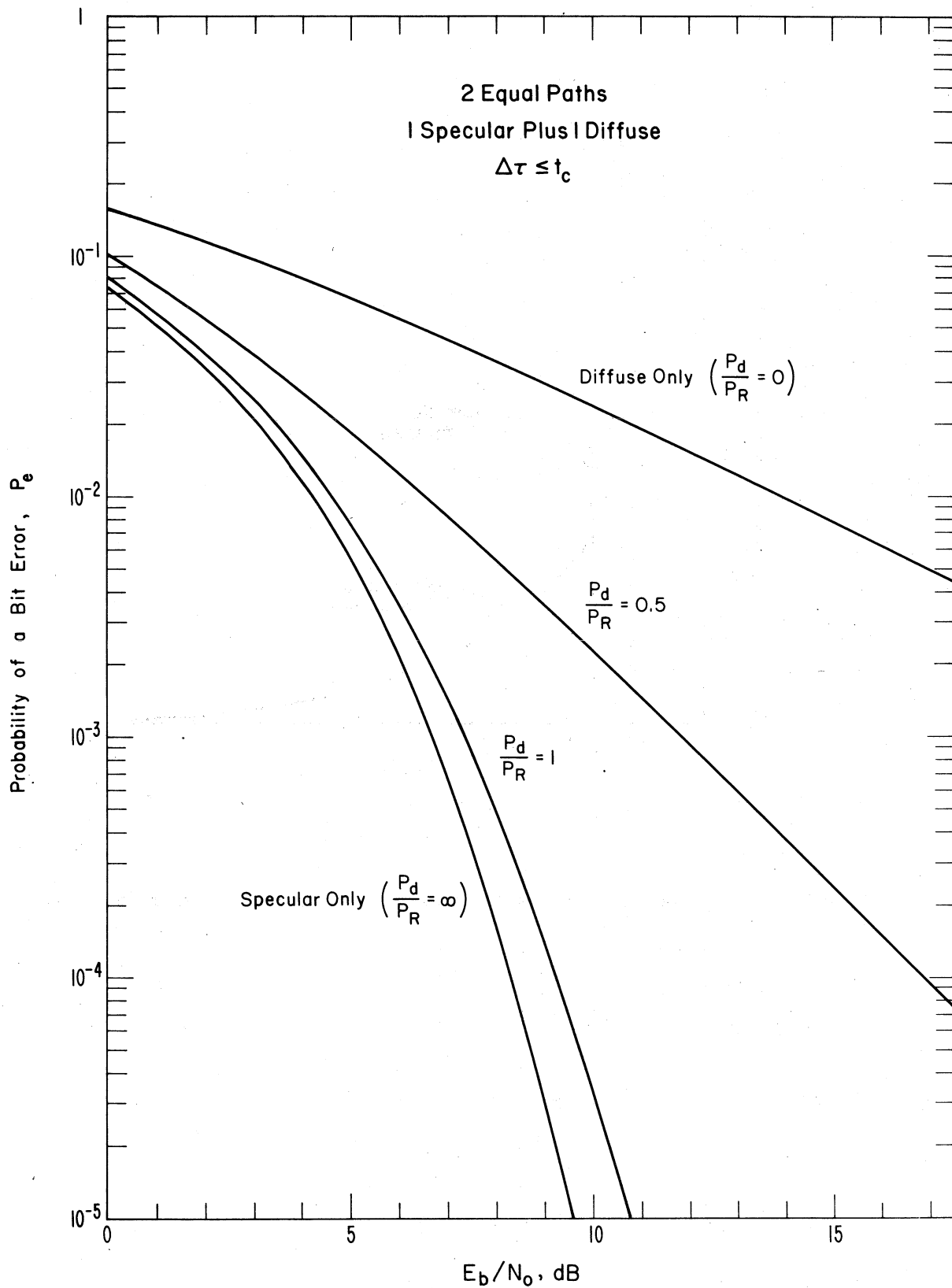

Figure 5. Performance of a 2-phase, CPSK DS system over a channel composed of a direct specular path plus a diffuse, Rayleigh fading, reflected path.

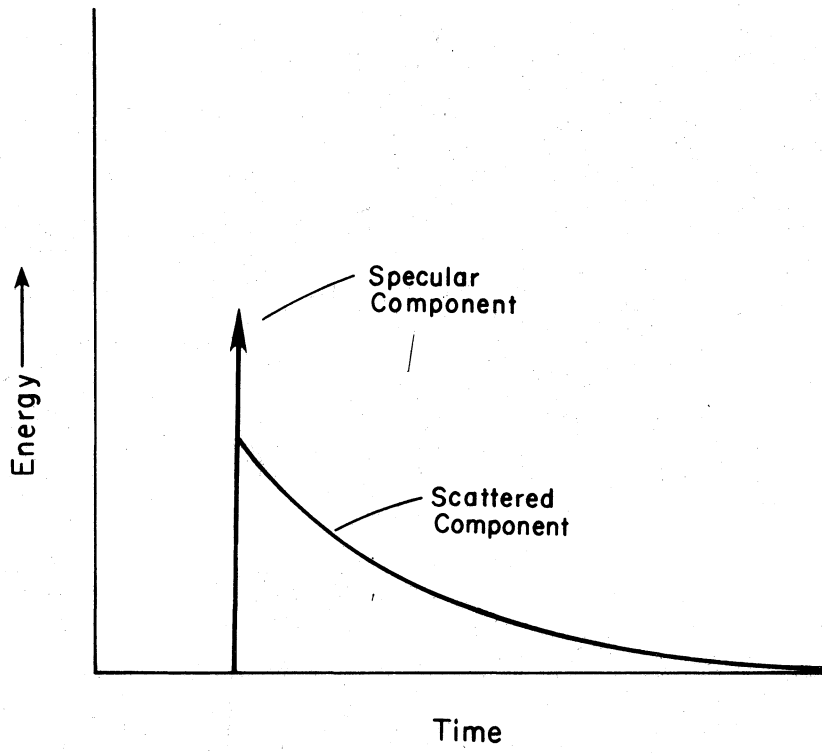

Figure 6. Channel impulse model used in performance calculations.

where ϕ is the parameter that determines the correlation bandwidth and a is the parameter that controls the ratio of specular to scattered energy. A value of $a = 1$ means complete specular propagation while $a = 0$ means only scatter propagation. Correlation bandwidth B_c is defined here as that Δf where

$$C(B_c) = 0.5 \quad . \quad (15)$$

Figure 6 shows the performance of this system for the case where there are $n = 32$ frequencies in the hopping sequence. The curves in this figure are parametric in a and B_c/B_{RF} , which is the ratio of the correlation bandwidth relative to the rf bandwidth. The curves labeled $B_c/B_{RF} = \infty$ are the limiting case where differential time delay is allowed to go to zero. Practically, $B_c/B_{RF} = \infty$ also represents the case where the time delay of all significant components are such that

$$\Delta\tau < \frac{1}{B_{RF}} \quad . \quad (16)$$

The second case shown in the curves is $B_c/B_{RF} = \frac{1}{16}$, which denotes a multipath situation where a significant fraction of the energy is arriving with time delays

$$\Delta\tau > \frac{1}{B_{RF}} \quad . \quad (17)$$

One should note that the error rate in Figure 7 is measured in terms of P_m , the symbol error probability. The reason for this is the system uses M-ary encoding where more than one bit is transmitted for each frequency-hopping pattern. The M-ary encoding also accounts for the fact that the system requires slightly less E_b/N_o than the DS system to achieve a given level of performance.

The important conclusions in regards to spread spectrum in multipath is that unlike narrowband digital systems the performance improves with increasing multipath time delays. Another fact that will be used throughout this report is that an SS system will probably require an E_b/N_o such that

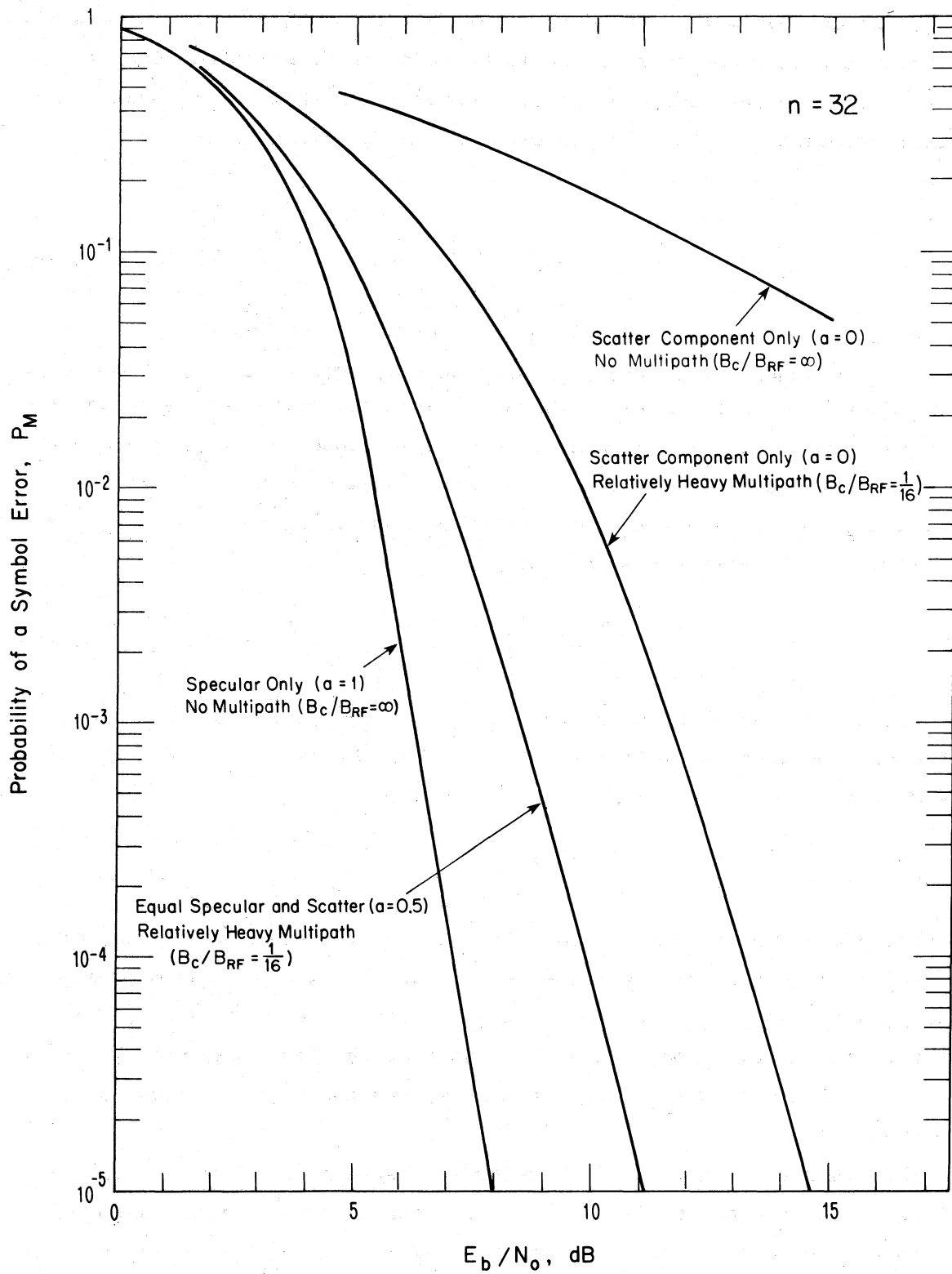

Figure 7. Expected performance of an $n = 32$ frequency hop system for various channel conditions.

$$10 \text{ dB} \leq E_b/N_o \leq 20 \text{ dB} \quad , \quad (18)$$

where the lower 10 dB limit would provide satisfactory performance in urban channels with a dominate specular path, while the 20 dB limit would be required in channels that are predominately diffuse. While it is admitted that these values are largely based on conjecture, they are supported to some extent by the previous discussion. Measurements of spread-spectrum systems in an urban environment would be needed to more accurately define the E_b/N_o requirements. The N_o here is Gaussian noise out of decorrelator due to non-Gaussian interference at the input to the decorrelator.

4. FM PERFORMANCE CALCULATIONS

The interaction between an FM receiver and an interfering, DS, spread-spectrum signal is reasonably straightforward. This is due to the fact that the IF filter in the FM receiver essentially transforms the wideband SS signal into Gaussian noise. Since the FM receiver is a filter with bandwidth b_{IF} , the ratio of average signal power to average noise power out of the FM receiver's IF and therefore at the input of the FM discriminator is

$$\frac{S}{N} \text{ DIS} = 10 \log \frac{b_{SS}}{b_{IF}} + \frac{S}{I} \text{ IN} \quad \text{dB} \quad , \quad (19)$$

where $\frac{S}{I}$ is the ratio of average signal power to average noise power at the input. Here b_{IF} is the IF bandwidth of the FM receiver and b_{SS} is the bandwidth of the SS signal as previously defined. This means that the signal-to-noise ratio after demodulation is given by

$$\frac{S}{N} \text{ OUT} = 10 \log [3\beta^2 (\beta + 1)] + 10 \log \frac{b_{SS}}{b_{IF}} + \frac{S}{I} \text{ IN} \quad \text{dB} \quad , \quad (20)$$

where the first term is the classical FM improvement factor and β is the modulation index (Stein and Jones, 1967). This equation assumes that interference is the dominate source of noise and that the receiver noise is negligible.

Equations (19) and (20) are valid only if the desired signal is specular and the value of S/N_{DIS} is sufficiently large that the receiver is operating

above threshold. The value of this threshold depends, of course, on whether or not the demodulator uses threshold extension techniques as well as the modulation index β . Figure 8 shows the threshold performance of an FM receiver both with and without threshold extension. As can be seen with $\beta = 2$, an S/N_{DIS} greater than 8 dB is required to be above threshold without threshold extension and greater than 4.5 dB with threshold extension. Thus with $\beta = 2$, the threshold occurs when S/N_{OUT} is 20 dB if threshold extension is used and 24 dB with conventional demodulation.

With fading, the output signal-to-noise ratio can be substantially less. Figure 8 shows what can happen when the desired signal is transmitted over a Rayleigh fading channel (Park and Chayaradhanangkur, 1977). The sharp threshold due to capture is no longer apparent. Also, the loss in signal-to-noise ratio for $\beta = 2$ is approximately 29 dB. This means that if a $S/N_{OUT} = 20$ dB is desired with $\beta = 2$, S/I_{DIS} must be approximately 33 dB. This loss is the result of additional noise from random phase modulation that is impressed upon the signal by the fading and the "click noise" that occurs when the FM signal is below threshold. Thus, throughout the report we will assume that

$$\frac{S}{N}_{OUT} = 10 \log[3\beta^2(\beta + 1)] + 10 \log \frac{b_{SS}}{b_{IF}} + \frac{S}{I}_{IN} - M_F \quad \text{dB} \quad , \quad (21)$$

where M_F has been added to account for fading. Since β for FM systems is typically about 2, this report will use a value of M_F

$$0 \leq M_F \leq 29 \text{ dB} \quad , \quad (22)$$

where the lower limit is typical of those urban propagation paths that are largely line-of-sight and the 29 dB limit is encountered on those (probably rare) paths that are largely diffuse (Rayleigh fading).

So far the discussion has avoided the effects of FH interference on FM. This has been intentional because of the different characteristics that can be encountered with FH interference. In order to observe these characteristics, we first define the hit rate as the number of times per second that the frequency hopper's frequency falls within the passband of the victim FM. If the hit rate is significantly greater than the IF bandwidth (nominally 10 kHz to 25 kHz) of the FM receiver, then the output of the IF will be very

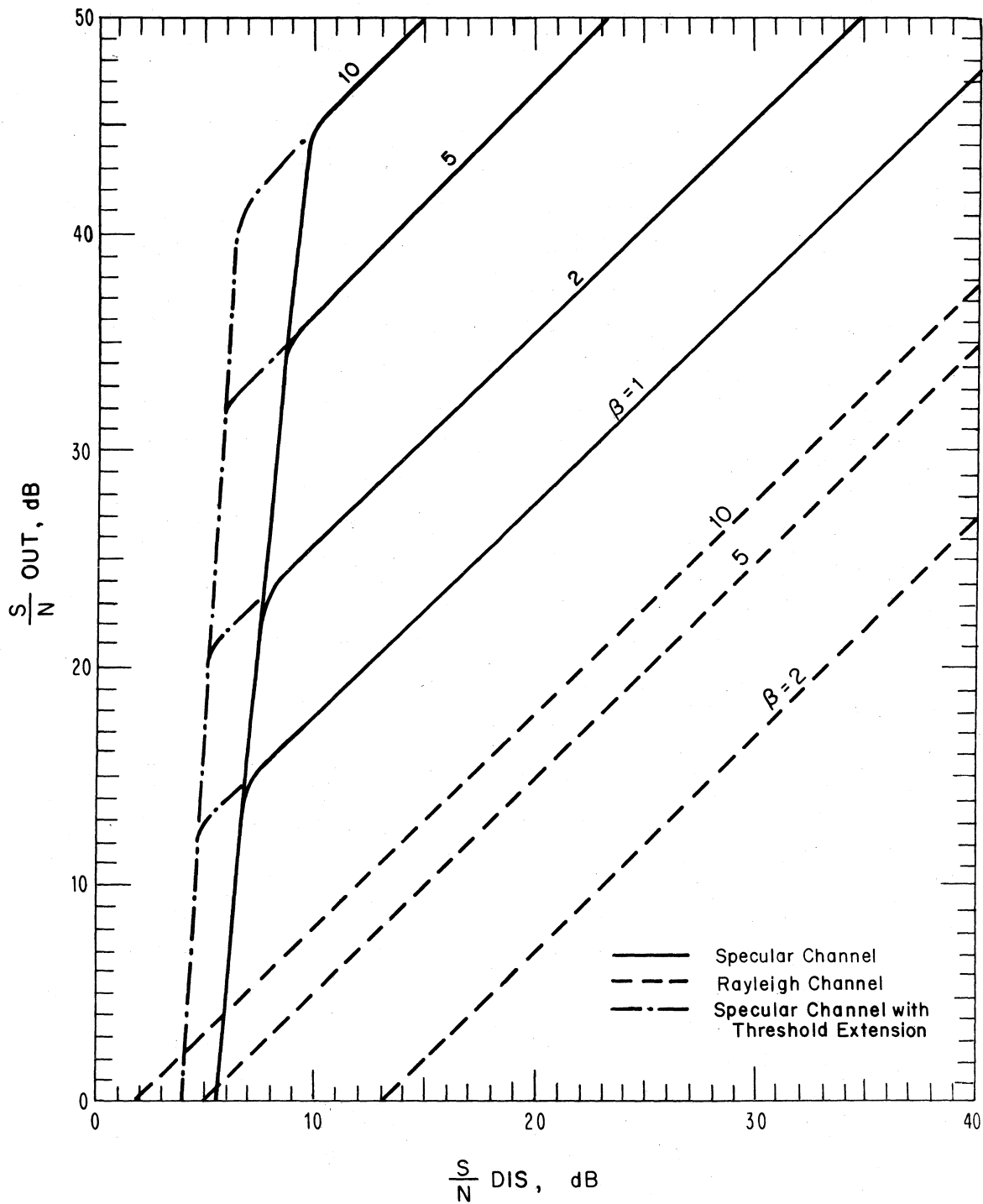

Figure 8. Signal-to-noise ratio out at an FM discriminator as a function of the signal-to-noise ratio into the discriminator for nonfading and Rayleigh fading channels.

nearly Gaussian. This is due to the fact that the impulse response time of the IF is significantly greater than the average duration between hits. Thus integration of the hits occurs and the output approaches Gaussian statistics. This means all of the assumptions made previously for DS also apply for FH in this instance.

As the hit rate is decreased to a value less than the IF bandwidth, the Gaussian assumption is no longer true since the IF now has sufficient time to fully respond to the interferer that has suddenly hopped into its passband. The output of the IF in this instance will become a pulse whose duration is determined by the hopping rate.

The effects of frequency hopping interference on the performance of an FM receiver remain largely unexplored and are beyond the scope of this limited report. A report by Hernandez (1975) which studies the performance of FM receivers in pulsed interference shows that the performance remains relatively constant with decreasing pulse rate, at least until rates of around 200 Hz. Therefore, one can summarize by saying that equation (21) can be expected to be valid for both DS and FH interference provided the hit rate from the FH system is greater than the IF bandwidth of 10 to 25 kHz. There is also some evidence to suggest that the equations are also valid with hit rates as low as 200 Hz.

5. PROPAGATION MODELS

One additional area that needs discussion before interference studies can be completed is in propagation. Antenna heights for base stations will be assumed to be at 200 m, which means that the median path loss between two base stations will be essentially line-of-sight as given by

(a) base-to-base $d \leq 64$ km

$$L(f,d) = 32.5 + 20 \log f(\text{MHz}) + 20 \log d(\text{km}) \text{ dB} , \quad (23)$$

The distance 64 km corresponds to the effective radio horizon between two such base stations. If the separation is greater than 64 km, the median path loss will be assumed as

(b) base-to-base $d > 64$ km

$$L(f,d) = 32.5 + 20 \log f(\text{MHz}) + 20 \log d(\text{km}) + C_4 + H_4 \log d(\text{km}) \text{ dB} , \quad (24)$$

where the constants C_4 and H_4 have been added to account for propagation over the radio horizon. Path loss for over the horizon propagation will be assumed to have a variation of distance of d^6 . For base-to-mobile propagation, the corresponding formulas for median path loss are

(c) base-to-mobile $d \leq 30$ km

$$L(f,d) = 32.5 + 20 \log f(\text{MHz}) + 20 \log d(\text{km}) + C_1 + H_1 \log d(\text{km}) \text{ dB} , \quad (25)$$

and

(d) base-to-mobile $d > 30$ km

$$L(f,d) = 32.5 + 20 \log f(\text{MHz}) + 20 \log d(\text{km}) + C_2 + H_2 \log d(\text{km}) \text{ dB} \quad (26)$$

These formulas are representative of the urban environment at frequencies between 150 and 900 MHz (Berry, 1978). The antenna height for the mobile is chosen as 1.5 m which accounts for the reduction in effective radio horizon to 30 km. The various constants used in these formulas are given in Table 1.

Table 1. Constants Used in Propagation Formulas

Frequency (MHz)	C_1 (dB)	C_2 (dB)	C_4 (dB)	H_1	H_2	H_4
150	19	-25.6	-72.2	10	40.3	40
450	20	-31.7	-72.2	10	45.4	40
900	23	-37.8	-72.2	10	50.4	40

The short-term fading around the median can be assumed to be Rayleigh distributed, while the long-term fading is log normal.

The discussion of propagation models also leads to the question of antenna gain. This report will assume omnidirectional antennas which means that the signal-to-interference calculations are independent of antenna gain. For example, consider the case where the signal level at the input terminals of an FM receiver is

$$S_{IN} = P_{FM} + A_{FM-T} + A_{FM-R} - L(f, d_{FM}) \text{ dB} , \quad (27)$$

where P_{FM} denotes FM transmitter power, A denotes antenna gain relative to isotropic, and $L(f, d_{FM})$ denotes the propagation loss encountered by the victim FM signal as described previously. The subscripts FM-T and FM-R have been added to denote transmitter and receiver, respectively. Similarly, the interference power at this point is

$$I_{IN} = P_{SS} + A_{SS-T} + A_{FM-R} - L(f, d_{SS}) \text{ dB} . \quad (28)$$

The subscripts SS have now been added to denote the spread-spectrum system. This means that the signal-to-interference ratio at this point is

$$\frac{S}{I} IN = P_{FM} - P_{SS} + A_{FM-T} - A_{SS-T} - L(f, d_{FM}) + L(f, d_{SS}) \text{ dB} . \quad (29)$$

If one further assumes that the antenna gain of the FM and SS transmitters are equal, then

$$\frac{S}{I} IN = P_{FM} - P_{SS} - L(f, d_{FM}) + L(f, d_{SS}) \text{ dB} . \quad (30)$$

The assumption that $A_{FM-T} = A_{SS-T}$ is probably a good assumption particularly if both antennas are omnidirectional.

6. SPREAD-SPECTRUM INTERFERENCE TO FM

The definition of interference throughout this report will be based on output signal-to-noise ratio. From the previous discussions in Section 4 on threshold, it is evident that with $\beta = 2$, the threshold level occurs when $S/I \text{ OUT} = 20 \text{ dB}$ in a specular propagation channel ($M_F = 0 \text{ dB}$). Although the sharp threshold no longer exists on a Rayleigh fading channel, a value of $S/I \text{ OUT} = 20 \text{ dB}$ would be considered a minimal level. Thus this report will define interference as

$$\frac{S}{N} \text{ OUT} \leq 20 \text{ dB} \quad . \quad (31)$$

Tables 2 and 3 list the equations that are used in this report for calculating $S/N \text{ OUT}$ due to interference from a single SS source. These equations are obtained by combining equations (21) and (30) with the appropriate path loss equation given in (23) through (26). The expressions therefore represent the median $S/I \text{ OUT}$ since they are based on median propagation losses.

These equations can be further reduced provided one is willing to make some assumptions. The first assumption is that the transmitter power in an SS system is going to be comparable to those currently used in FM. Although this is strictly conjecture, it has already been shown that the E_b/N_o requirements for a DS system and a narrowband CPSK system are the same in a non-fading, Gaussian, additive-noise situation. The only advantages occur on propagation channels with severe multipath or channels with narrowband interference. This report thus assumes that

$$P_{SS} = P_{FM} \quad . \quad (32)$$

Since b_{IF} will probably vary somewhat depending on receiver quality, this report will use the value

$$b_{IF} = 25 \text{ kHz} \quad (33)$$

and

$$\beta = 2 \quad ; \quad (34)$$

Table 2. Equations of Output Signal-to-Noise Ratio for an FM Base Station Receiving Interference from an SS Base Station

d_{FM} (km)	d_{SS} (km)	$\frac{S}{N}$ OUT
≤ 30	≤ 64	$\frac{S}{N}$ OUT = $P_{FM} - P_{SS} - C_1 - (20+H_1) \log d_{FM} + 20 \log d_{SS} + 10 \log \frac{b_{SS}}{b_{IF}} + 10 \log 3\beta^2(\beta+1) - M_F$
> 30	≤ 64	$\frac{S}{N}$ OUT = $P_{FM} - P_{SS} - C_2 - (20+H_2) \log d_{FM} + 20 \log d_{SS} + 10 \log \frac{b_{SS}}{b_{IF}} + 10 \log 3\beta^2(\beta+1) - M_F$
≤ 30	> 64	$\frac{S}{N}$ OUT = $P_{FM} - P_{SS} - C_1 + C_4 - (20+H_1) \log d_{FM} + (20+H_4) \log d_{SS} + 10 \log \frac{b_{SS}}{b_{IF}} + 10 \log 3\beta^2(\beta+1) - M_F$
> 30	> 64	$\frac{S}{N}$ OUT = $P_{FM} - P_{SS} - C_2 + C_4 - (20+H_2) \log d_{FM} + (20+H_4) \log d_{SS} + 10 \log \frac{b_{SS}}{b_{IF}} + 10 \log 3\beta^2(\beta+1) - M_F$

Table 3. Equations of Output Signal-to-Noise Ratio for an FM Base Station Receiving Interference from an SS Mobile or an FM Mobile Receiving Interference from an SS Base Station

d_{FM} (km)	d_{SS} (km)	$\frac{S}{N}$ OUT
≤ 30	≤ 30	$\frac{S}{N}$ OUT = $P_{FM} - P_{SS} - (20+H_1) \log d_{FM} + (20+H_1) \log d_{SS} + 10 \log \frac{b_{SS}}{b_{IF}} + 10 \log 3\beta^2(\beta+1) - M_F$
> 30	≤ 30	$\frac{S}{N}$ OUT = $P_{FM} - P_{SS} + C_1 - C_2 - (20+H_2) \log d_{FM} + (20+H_1) \log d_{SS} + 10 \log \frac{b_{SS}}{b_{IF}} + 10 \log 3\beta^2(\beta+1) - M_F$
≤ 30	> 30	$\frac{S}{N}$ OUT = $P_{FM} - P_{SS} - C_1 + C_2 - (20+H_1) \log d_{FM} + (20+H_2) \log d_{SS} + 10 \log \frac{b_{SS}}{b_{IF}} + 10 \log 3\beta^2(\beta+1) - M_F$
> 30	> 30	$\frac{S}{N}$ OUT = $P_{FM} - P_{SS} - (20+H_2) \log d_{FM} + (20+H_2) \log d_{SS} + 10 \log \frac{b_{SS}}{b_{FM}} + 10 \log 3\beta^2(\beta+1) - M_F$

then the equations in Tables 2 and 3 can be solved for d_{SS} as a function of d_{FM} in order to produce the graphs shown in Figures 9 through 12. Here d_{SS} corresponds to the SS separation distance that is necessary to insure that there is no interference ($S/I_{OUT} > 20$ dB) and is plotted as a function of d_{FM} , the victim FM transmission distance. Figure 9 shows the geometry involved in measuring d_{SS} and d_{FM} .

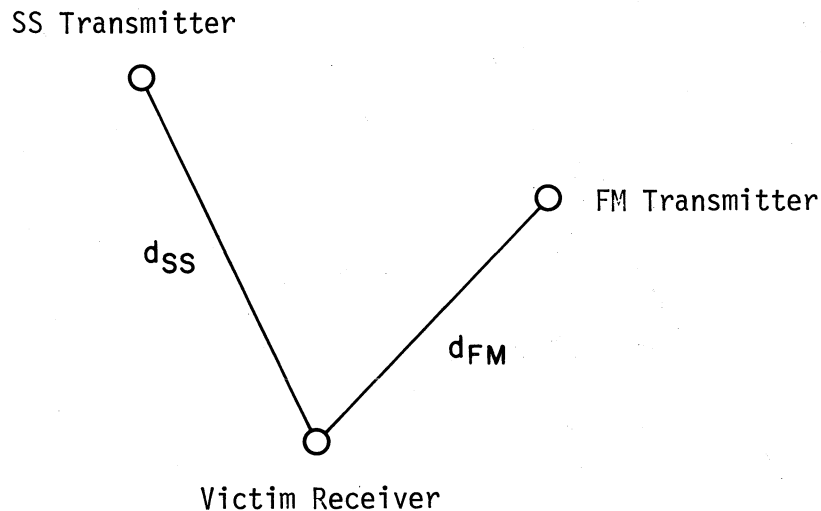

Figure 9. Geometry involved in measuring d_{SS} and d_{FM} .

Figure 10 shows the results for a transmission frequency of 150 MHz with interference from an SS base transmitter to an FM base receiver. These curves are plotted for SS bandwidths of 1 and 10 MHz. As expected, the separation requirements for the wider bandwidth 10 MHz system are less. The curves are also plotted for $M_F = 0$ and 29 dB, which represents the two extremes in propagation conditions when $\beta = 2$. Practically, most propagation channels will probably be somewhere in-between these extremes. The discontinuities that appear in the curves are due to the propagation models and occur when either the SS interferer or FM victim pass over the effective radio horizon. The actual transitions are not abrupt as shown, but gradually change as one crosses the radio horizon. Figure 11 is similar to 10 except the interference is from an SS mobile to an FM base.

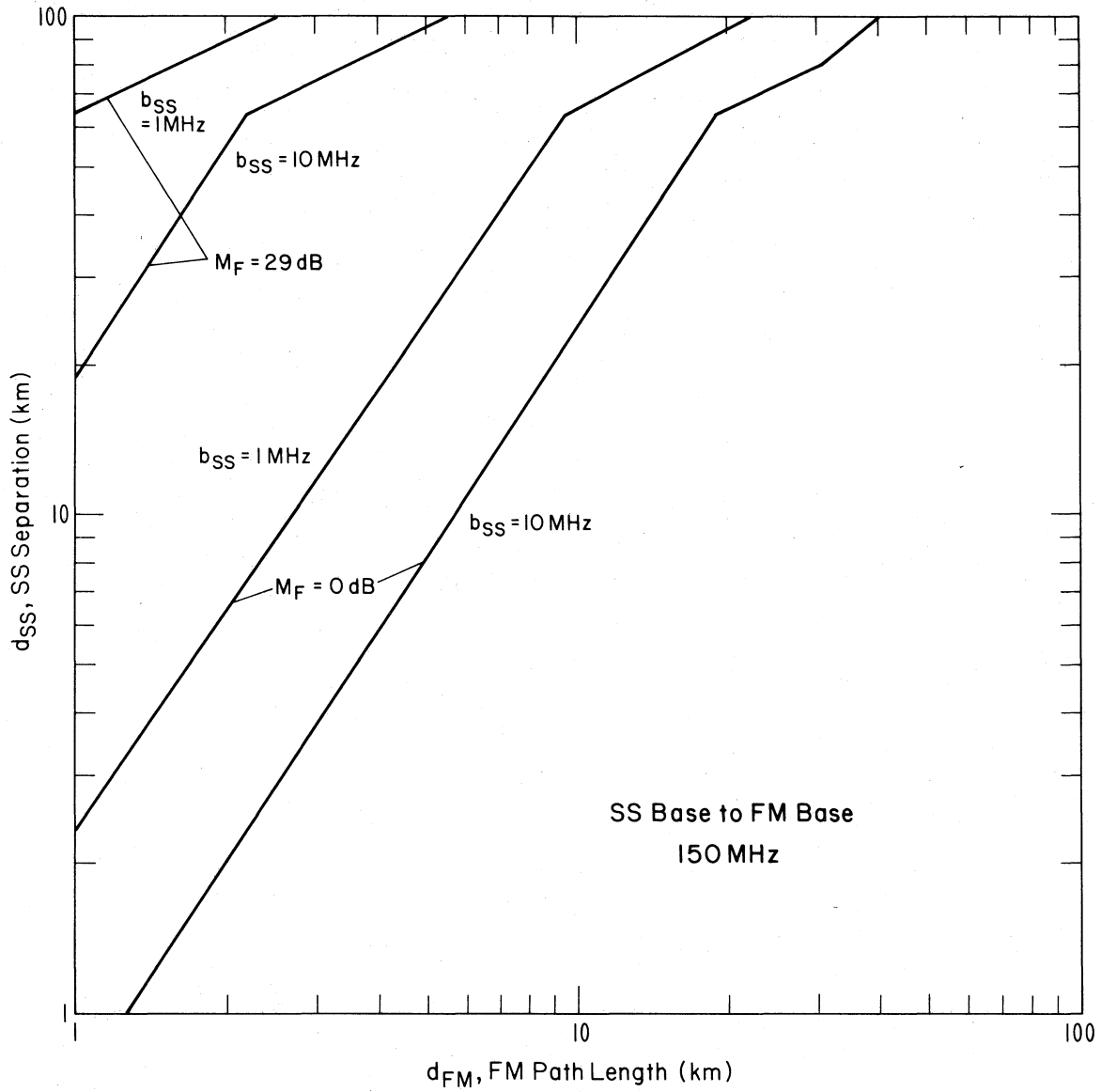

Figure 10. Separation distance d_{SS} versus d_{FM} to insure that $S/I \text{ OUT} > 20 \text{ dB}$. SS base interference to an FM base station, 150 MHz.

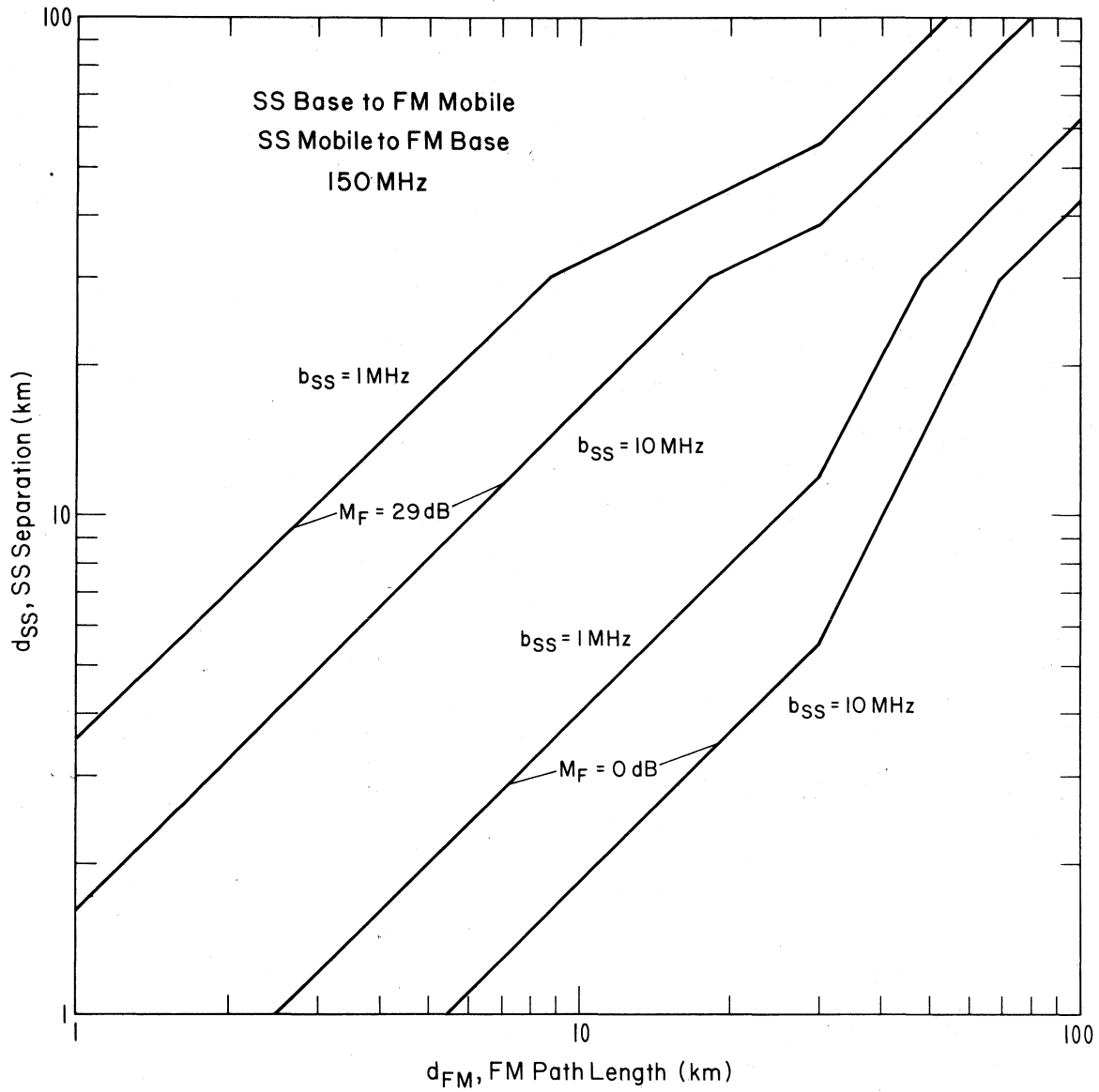

Figure 11. Separation distance d_{SS} versus d_{FM} to insure that $S/I_{OUT} > 20\text{ dB}$. SS base interference to an FM mobile, or SS mobile interference to an FM base, 150 MHz.

Separation requirements for propagation at 900 MHz are shown in Figures 12 and 13. By comparing Figures 10 and 12, one can see that SS base to FM base interference is worse at 900 MHz than at 150 MHz since greater separation distances are required. However, the mobile-to-base or base-to-mobile curves at the two frequencies are nearly identical. Only slight differences occur when either d_{SS} or d_{FM} is over the effective radio horizon. The reason for this is that the increased channel losses at 900 MHz due to the urban environment are incurred by both the victim and interferer in the case of mobile-to-base or base-to-mobile propagation. This is not true with base-to-base interference since the victim path is a mobile-to-base path that has additional losses due to the urban clutter while the interference is base-to-base which, because of the antenna heights, is assumed to be line-of-sight with free space propagation losses.

Additional insight can be gained if the curves are plotted in a different manner. Figure 14 shows the base-to-base and mobile-to-base curves for the $b_{SS} = 1$ MHz system. Shading is added to dramatize where interference is considered to be "highly probable," which is defined as the condition where $S/I_{OUT} < 20$ dB even with $M_F = 0$ dB. Also shown with shading, are regions considered to be "propagation dependent," which means that $S/I_{OUT} < 20$ can occur depending on the channel characteristics ($0 \leq M_F \leq 29$ dB). Unshaded regions are considered to be free from interference since $S/I_{OUT} > 20$ even if $M_F = 29$ dB. Figure 15 shows the corresponding results for a 10 MHz spread-spectrum system at 150 MHz, while Figures 16 and 17 give the results for operation at 900 MHz.

A summary of separation distances, d_{SS} , for a 1 MHz SS system is listed in Table 4. This summary is for desired transmission distances of $d_{FM} = 10$ and 30 km. Values for d_{SS} in the tables correspond to the range expected with channel conditions of $0 \leq M_F \leq 29$ dB. Table 5 gives the corresponding results for a 10 MHz SS system.

The reader is again cautioned that the results here are based on the median values of S/I IN. In reality both S and I can be expected to have a variability due to the motion of the FM mobile and the interfering SS mobile. The effect of the varying I on the system performance is another unknown that needs to be explored.

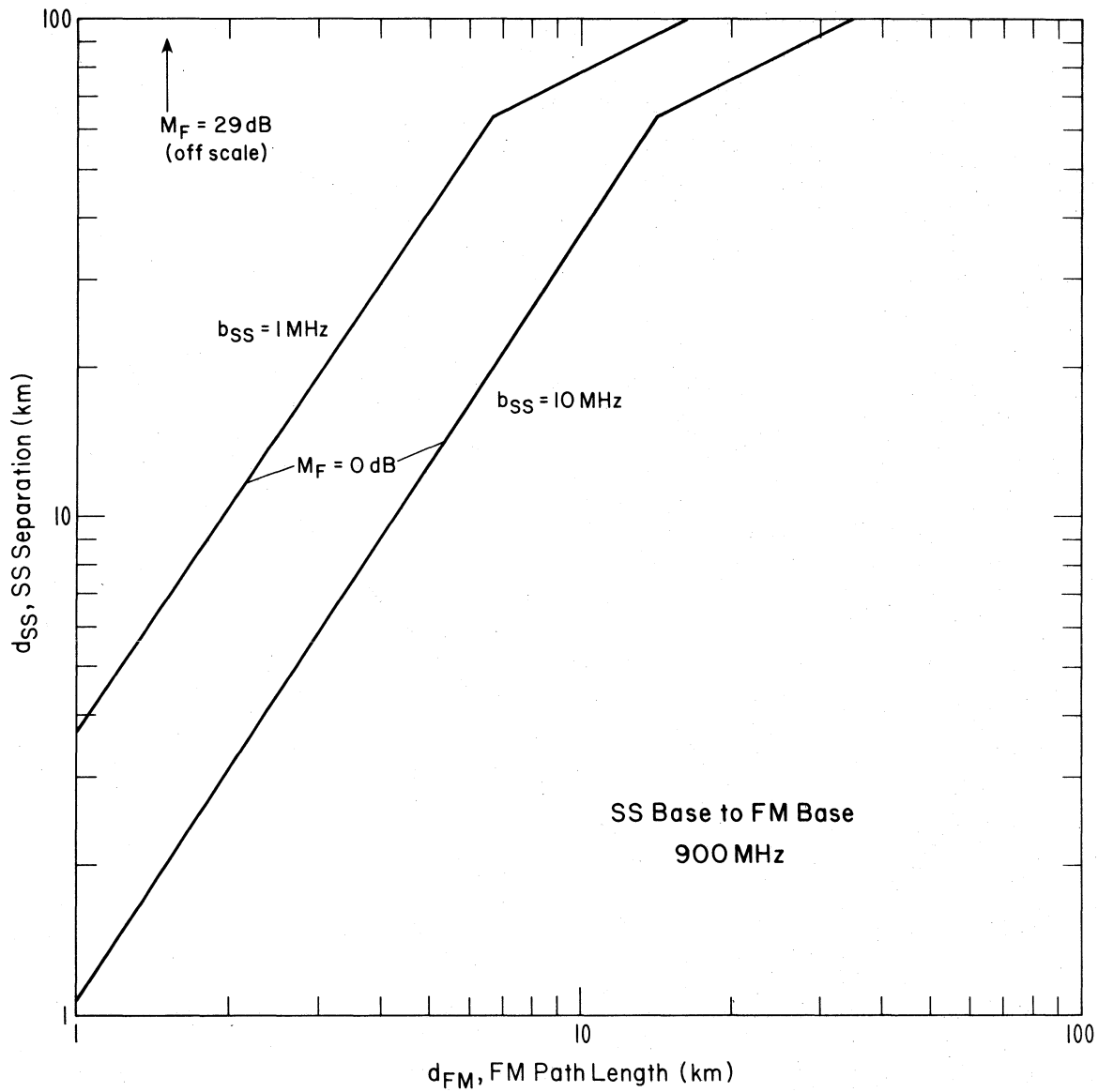

Figure 12. Separation distance d_{SS} versus d_{FM} to insure that $S/I \text{ OUT} > 20 \text{ dB}$. SS base interference to an FM base, 900 MHz.

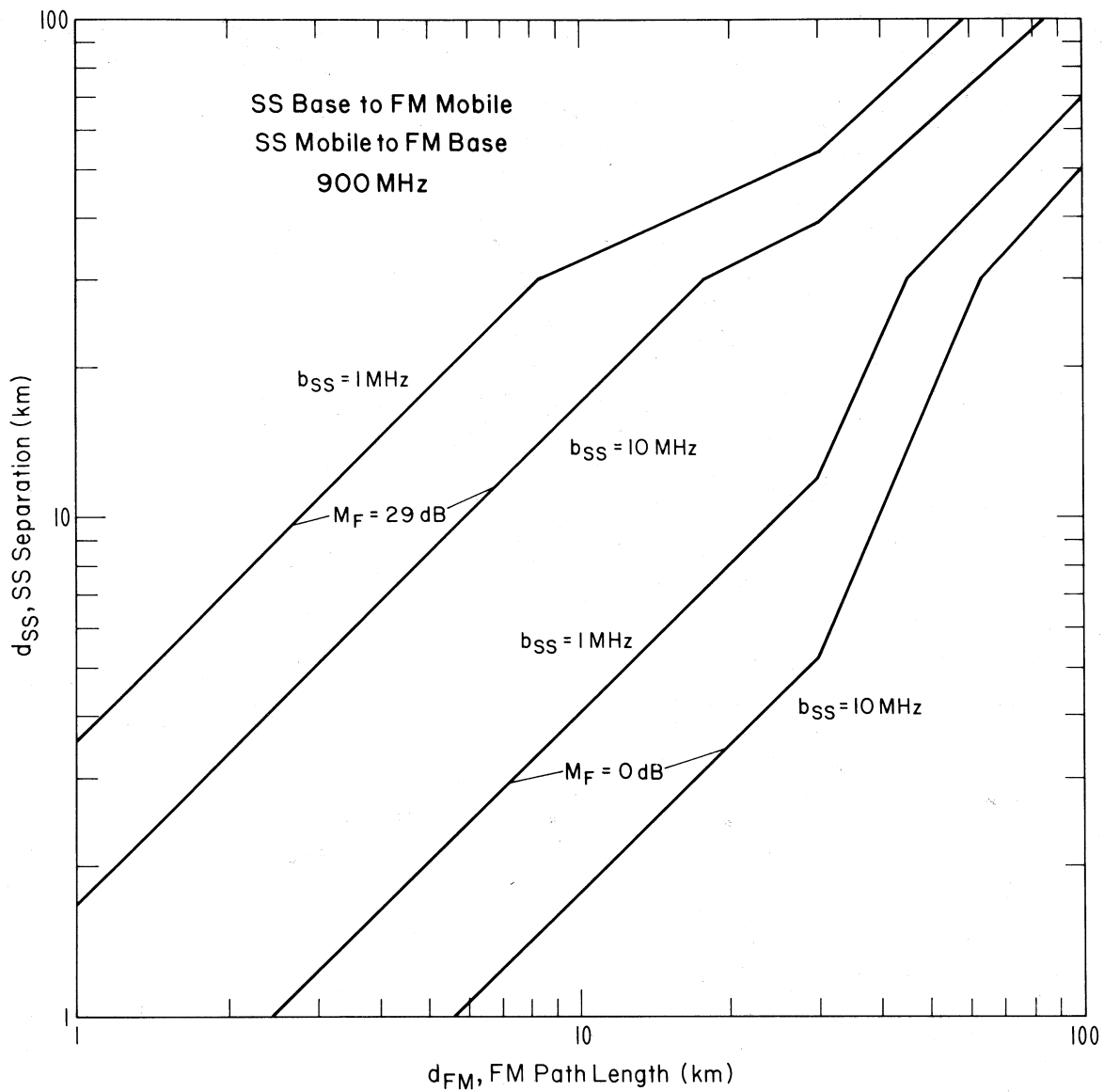





Figure 13. Separation distance d_{SS} versus d_{FM} to insure that $S/I_{OUT} > 20 \text{ dB}$. SS base interference to an FM mobile, or SS mobile interference to an FM base, 900 MHz.

-  SS Base Interference to FM Base - Propagation Dependent
-  SS Base Interference to FM Base - Highly Probable
-  SS Base (Mobile) Interference to FM Mobile (Base) - Propagation Dependent
-  SS Base (Mobile) Interference to FM Mobile (Base) - Highly Probable

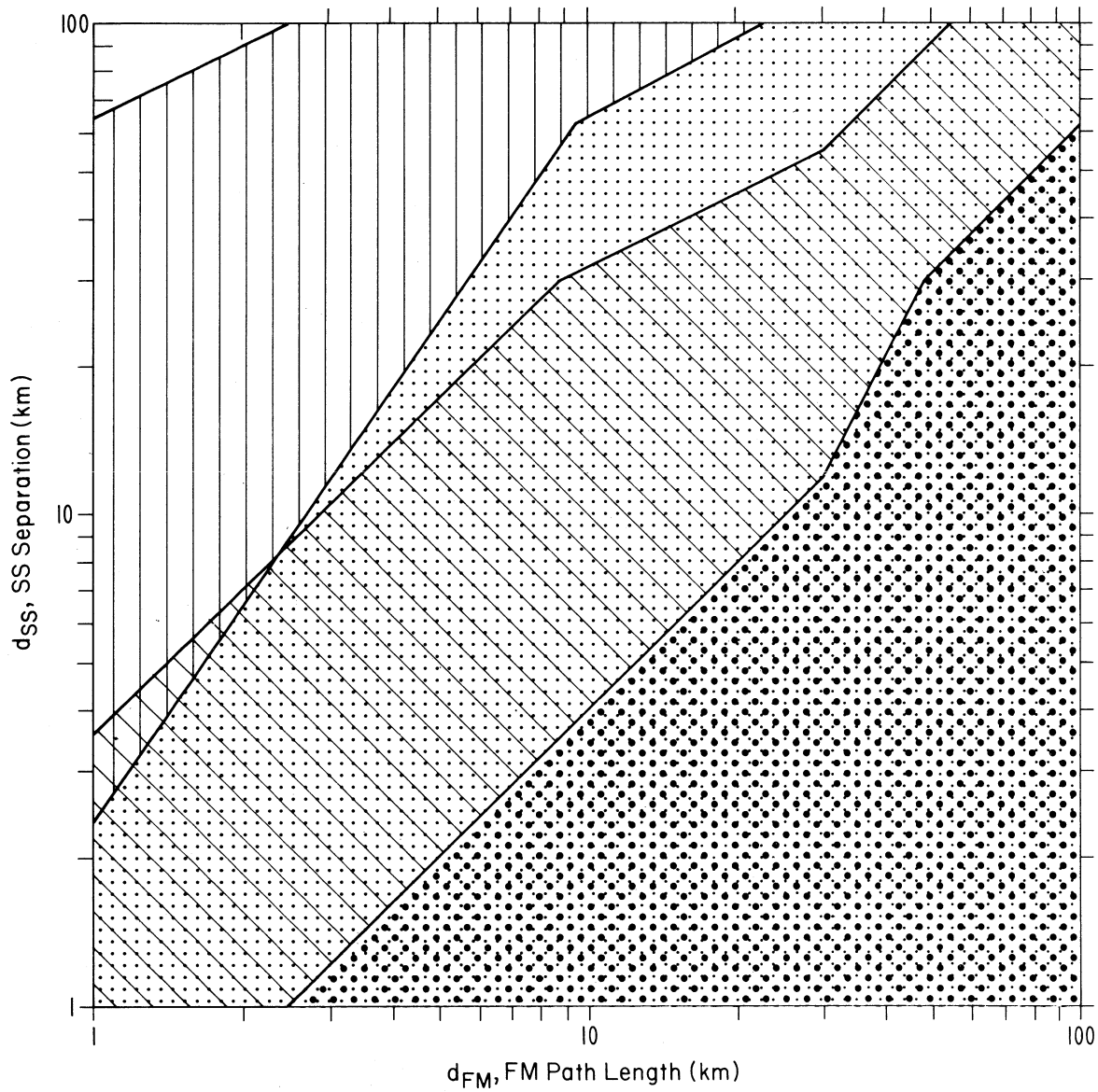





Figure 14. Separation distance d_{SS} versus d_{FM} that is required to insure that $S/I_{OUT} > 20$ dB with a 1 MHz SS system at 150 MHz.

-  SS Base Interference to FM Base - Propagation Dependent
-  SS Base Interference to FM Base - Highly Probable
-  SS Base (Mobile) Interference to FM Mobile (Base) - Propagation Dependent
-  SS Base (Mobile) Interference to FM Mobile (Base) - Highly Probable

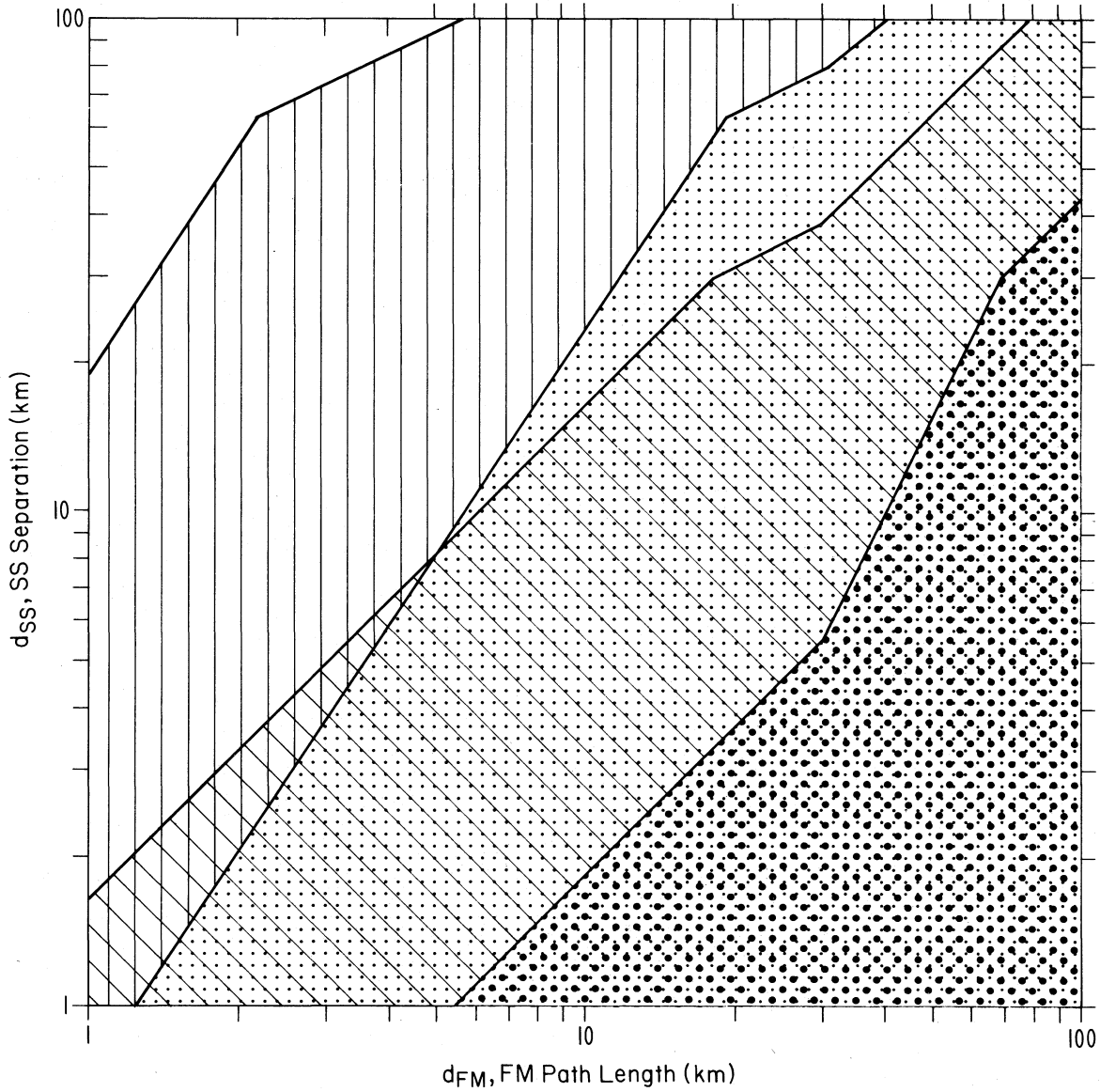





Figure 15. Separation distance d_{SS} versus d_{FM} that is required to insure that $S/I_{OUT} > 20$ dB with a 10 MHz SS system at 150 MHz.

-  SS Base Interference to FM Base - Propagation Dependent
-  SS Base Interference to FM Base - Highly Probable
-  SS Base (Mobile) Interference to FM Mobile (Base) - Propagation Dependent
-  SS Base (Mobile) Interference to FM Mobile (Base) - Highly Probable

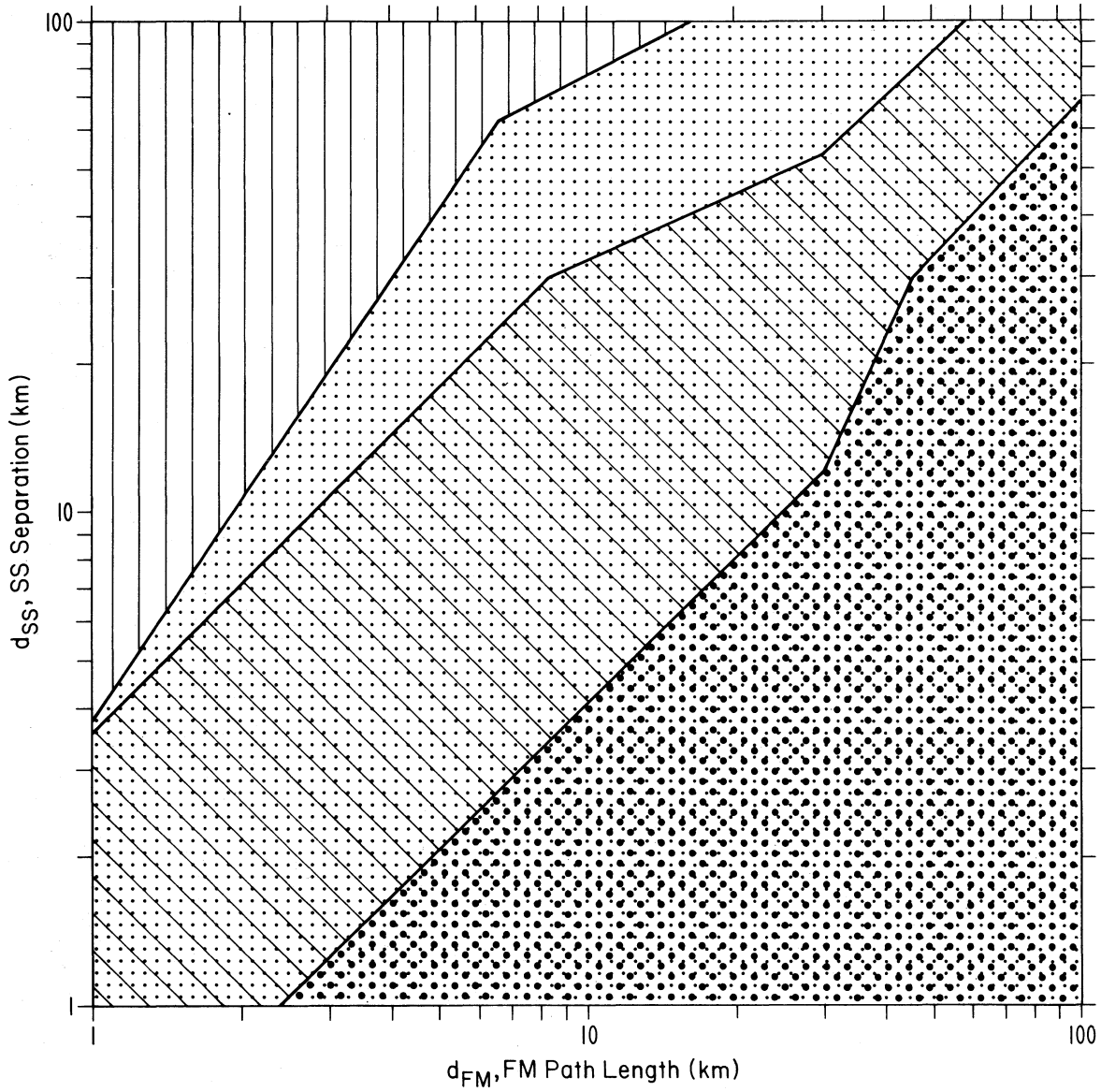





Figure 16. Separation distance d_{SS} versus d_{FM} that is required to insure that $S/I_{OUT} > 20$ dB with a 1 MHz SS system at 900 MHz.

-  SS Base Interference to FM Base - Propagation Dependent
-  SS Base Interference to FM Base - Highly Probable
-  SS Base (Mobile) Interference to FM Mobile (Base) - Propagation Dependent
-  SS Base (Mobile) Interference to FM Mobile (Base) - Highly Probable

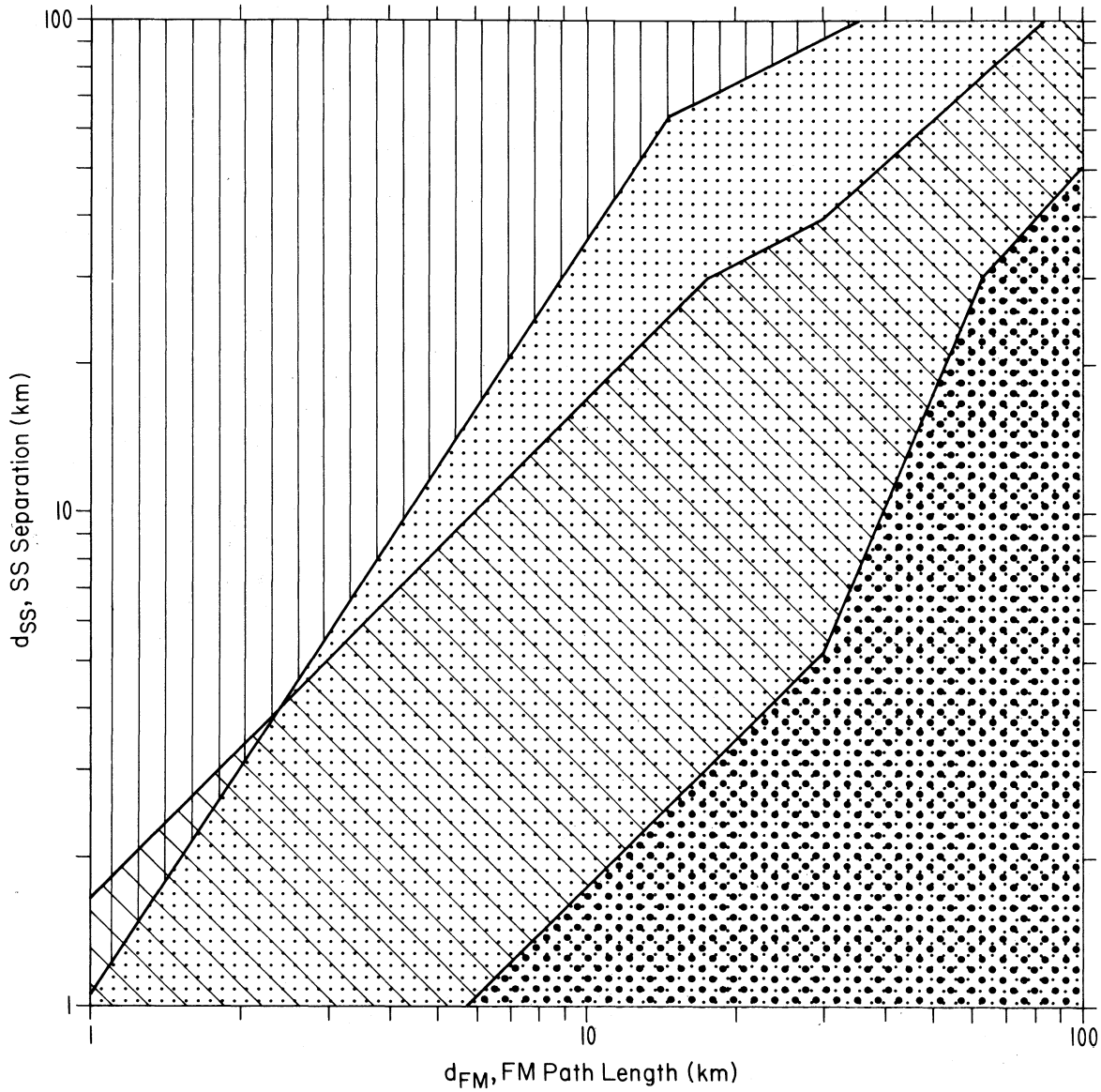

Figure 17. Separation distance d_{SS} versus d_{FM} that is required to insure that $S/I_{OUT} > 20$ dB with a 10 MHz SS system at 900 MHz.

Table 4. Summary of Separation Distance, d_{SS} , that is Required to Insure S/I OUT > 20 dB (SS System Bandwidth is 1 MHz)

Interference	d_{FM} (km)	d_{SS} (km)	f (MHz)
SS Mobile to FM Base *	10	4-22	150
	30	12-52	150
SS Base to FM Base	10	>64	150
	30	>100	150
SS Mobile to FM Base *	10	4-22	900
	30	12-52	900
SS Base to FM Base	10	>80	900
	30	>100	900

Table 5. Summary of Separation Distance, d_{SS} , that is Required to Insure S/I OUT > 20 dB (SS System Bandwidth is 10 MHz)

Interference	d_{FM} (km)	d_{SS} (km)	f (MHz)
SS Mobile to FM Base *	10	2-15	150
	30	5-29	150
SS Base to FM Base	10	>22	150
	30	>80	150
SS Mobile to FM Base *	10	2-17	900
	30	5-40	900
SS Base to FM Base	10	>35	900
	30	>85	900

* Also applicable for an SS base interfering with an FM mobile.

7. FM INTERFERENCE TO SPREAD-SPECTRUM

7.1 Single FM Interference

Interference curves similar to those shown in the last chapter can also be produced for the reverse situation of FM interference to an SS system. Tables 6 and 7 summarize the equations that are applicable in this instance and were obtained by combining (13) and (30) with the appropriate path loss equation in (23) through (26). As discussed previously, the performance of a digital system in interference is determined by the E_b/N_o out of the decorrelator. For a binary SS system ($k = 1$), the requirements for E_b/N_o were previously determined to be

$$10 \text{ dB} \leq E_b/N_o \leq 20 \text{ dB} \quad (35)$$

depending on channel and multipath conditions.

Graphs showing the separation distance d_{FM} that are required to protect an SS system transmitting over a desired path d_{SS} are shown in Figures 18 through 21. The interferer's propagation path is now d_{FM} . Shading is again used to denote the various propagation conditions, and areas labeled propagation dependent occur when $10 \text{ dB} \leq E_b/N_o \leq 20 \text{ dB}$. Conversely the curves labeled highly probable occur when $E_b/N_o < 10 \text{ dB}$. A summary of these results is presented in Tables 8 and 9.

The RF bandwidth b_{RF} required by a $G_p = 30$ or 40 dB SS system depends on the system design as well as the information being sent. Current state-of-the-art in voice digitizing enables satisfactory voice recovery with digitizing rates below 10 kHz. Thus, conceivably b_{SS} for a $G_p = 30$ dB system could be as low as 1 MHz while a $G_p = 40$ dB system would probably require 10 MHz.

7.2 Multiple FM Interference

The analysis so far has only considered the separation requirements for a single FM source interfering with a single SS receiver. However, since the FM channels are 25 kHz wide, a 10 MHz SS receiver could conceivably receive up to $10/.025 = 400$ simultaneous interferers. Practically, one would expect only a small fraction of this number to be on at any given instant in time.

Table 6. Equations of Output Signal-to-Noise Ratio, E_b/N_o , for an SS Base Station Receiving Interference from an FM Base Station

d_{SS} (km)	d_{FM} (km)	E_b/N_o , dB
≤ 30	≤ 64	$\frac{E_b}{N_o} = P_{SS} - P_{FM} - C_1 - (20+H_1) \log d_{SS} + 20 \log d_{FM} + G_p$
> 30	≤ 64	$\frac{E_b}{N_o} = P_{SS} - P_{FM} - C_2 - (20+H_2) \log d_{SS} + 20 \log d_{FM} + G_p$
≤ 30	> 64	$\frac{E_b}{N_o} = P_{SS} - P_{FM} - C_1 + C_4 - (20+H_1) \log d_{SS} + (20+H_4) \log d_{FM} + G_p$
> 30	> 64	$\frac{E_b}{N_o} = P_{SS} - P_{FM} - C_2 + C_4 - (20+H_2) \log d_{SS} + (20+H_4) \log d_{FM} + G_p$

Table 7. Equations of Output Signal-to-Noise Ratio, E_b/N_o , for an SS Base Station Receiving Interference from an FM Mobile or an SS Mobile Receiving Interference from an FM Base Station

d_{SS} (km)	d_{FM} (km)	E_b/N_o , dB
≤ 30	≤ 30	$\frac{E_b}{N_o} = P_{SS} - P_{FM} - (20+H_1) \log d_{SS} + (20+H_1) \log d_{FM} + G_p$
> 30	≤ 30	$\frac{E_b}{N_o} = P_{SS} - P_{FM} + C_1 - C_2 - (20+H_2) \log d_{SS} + (20+H_1) \log d_{FM} + G_p$
≤ 30	> 30	$\frac{E_b}{N_o} = P_{SS} - P_{FM} - C_1 + C_2 - (20+H_1) \log d_{SS} + (20+H_2) \log d_{FM} + G_p$
> 30	> 30	$\frac{E_b}{N_o} = P_{SS} - P_{FM} - (20+H_2) \log d_{SS} + (20+H_2) \log d_{FM} + G_p$

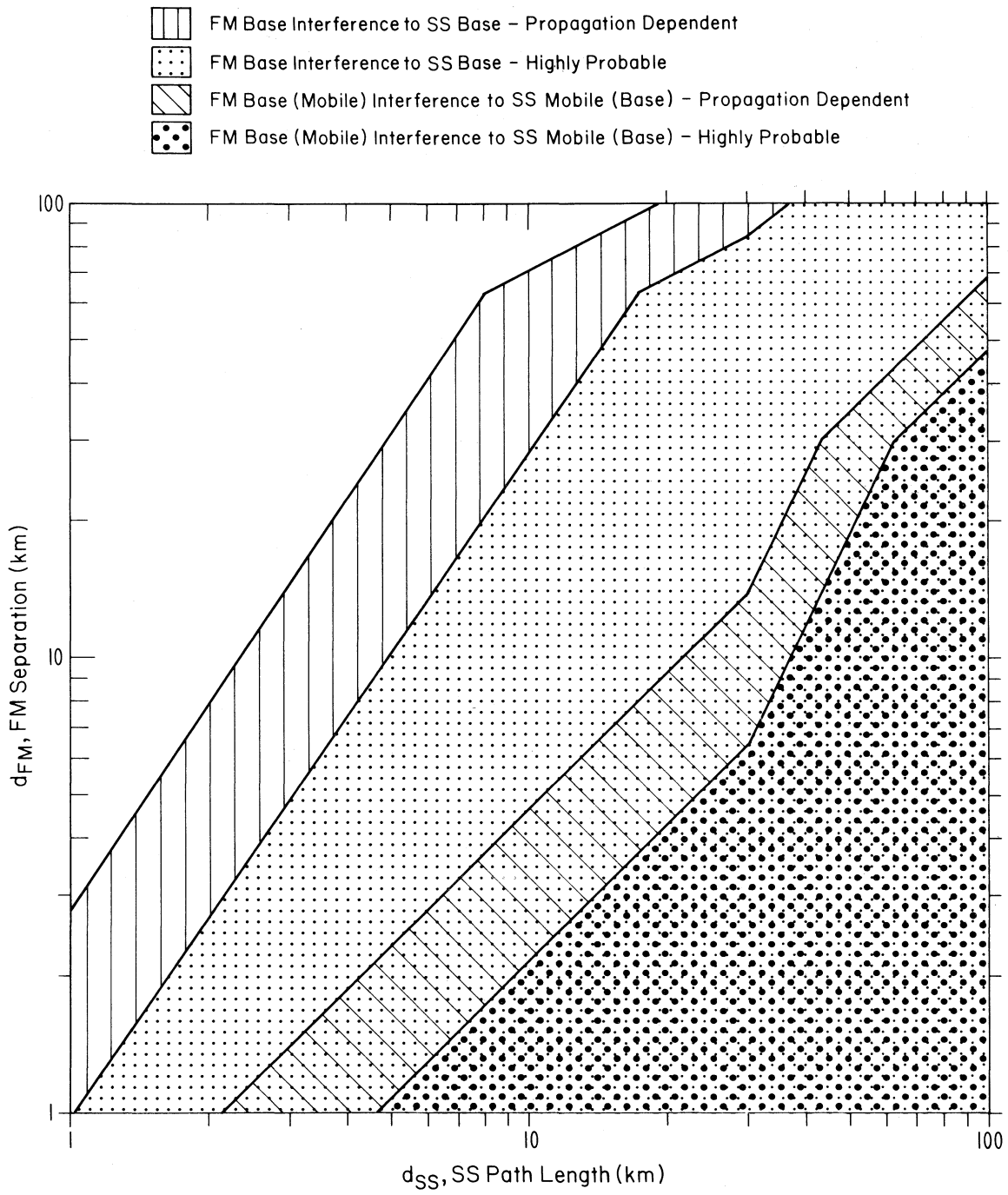





Figure 18. Separation distance d_{FM} versus d_{SS} that is required to insure $10 \text{ dB} \leq E_b/N_o \leq 20 \text{ dB}$ with $G_p = 30 \text{ dB}$, 150 MHz.

-  FM Base Interference to SS Base - Propagation Dependent
-  FM Base Interference to SS Base - Highly Probable
-  FM Base (Mobile) Interference to SS Mobile (Base) - Propagation Dependent
-  FM Base (Mobile) Interference to SS Mobile (Base) - Highly Probable

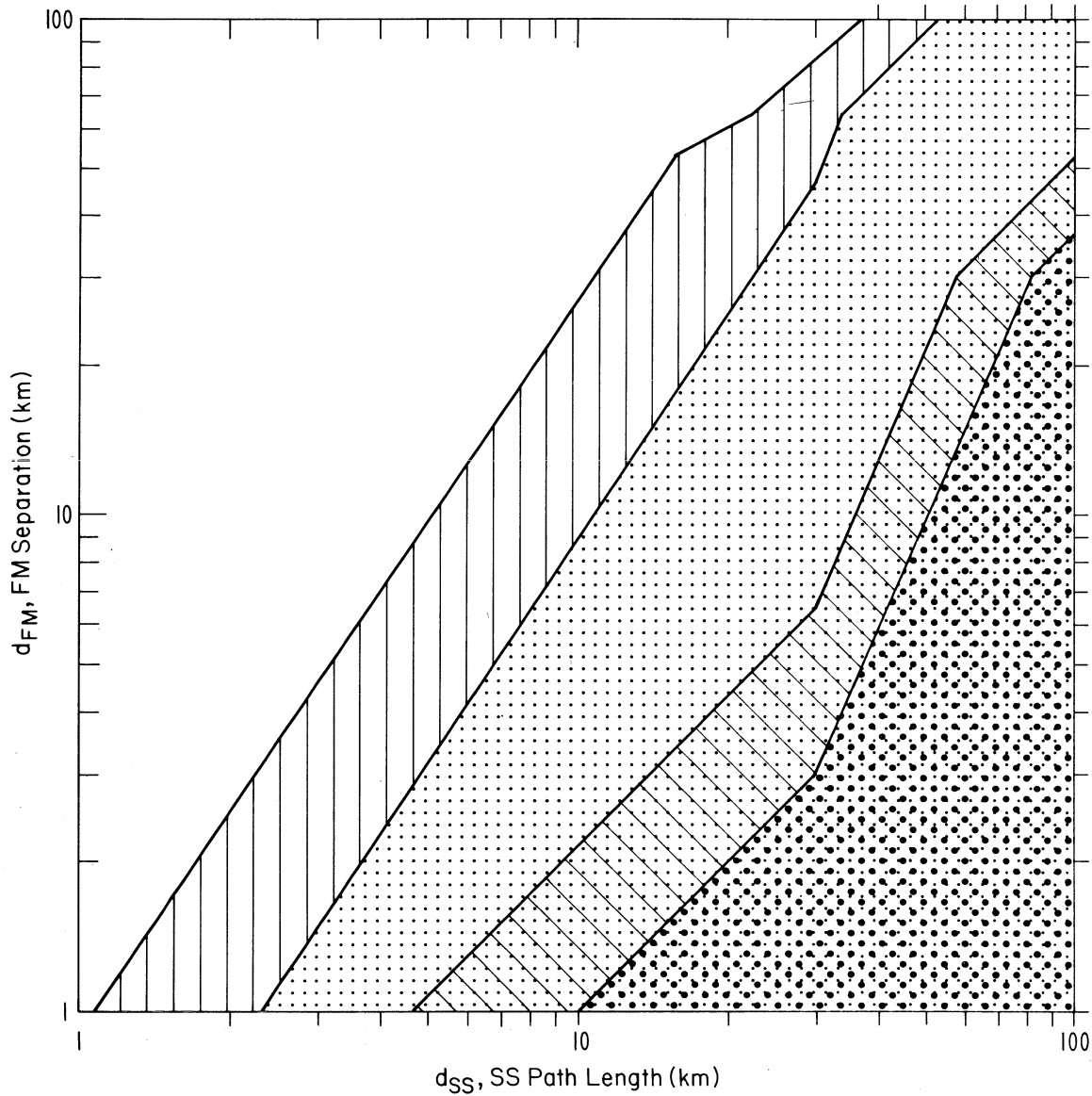





Figure 19. Separation distance d_{FM} versus d_{SS} that is required to insure $10 \text{ dB} \leq E_b/N_o \leq 20 \text{ dB}$, with $G_p = 40 \text{ dB}$, 150 MHz.

-  FM Base Interference to SS Base - Propagation Dependent
-  FM Base Interference to SS Base - Highly Probable
-  FM Base (Mobile) Interference to SS Mobile (Base) - Propagation Dependent
-  FM Base (Mobile) Interference to SS Mobile (Base) - Highly Probable

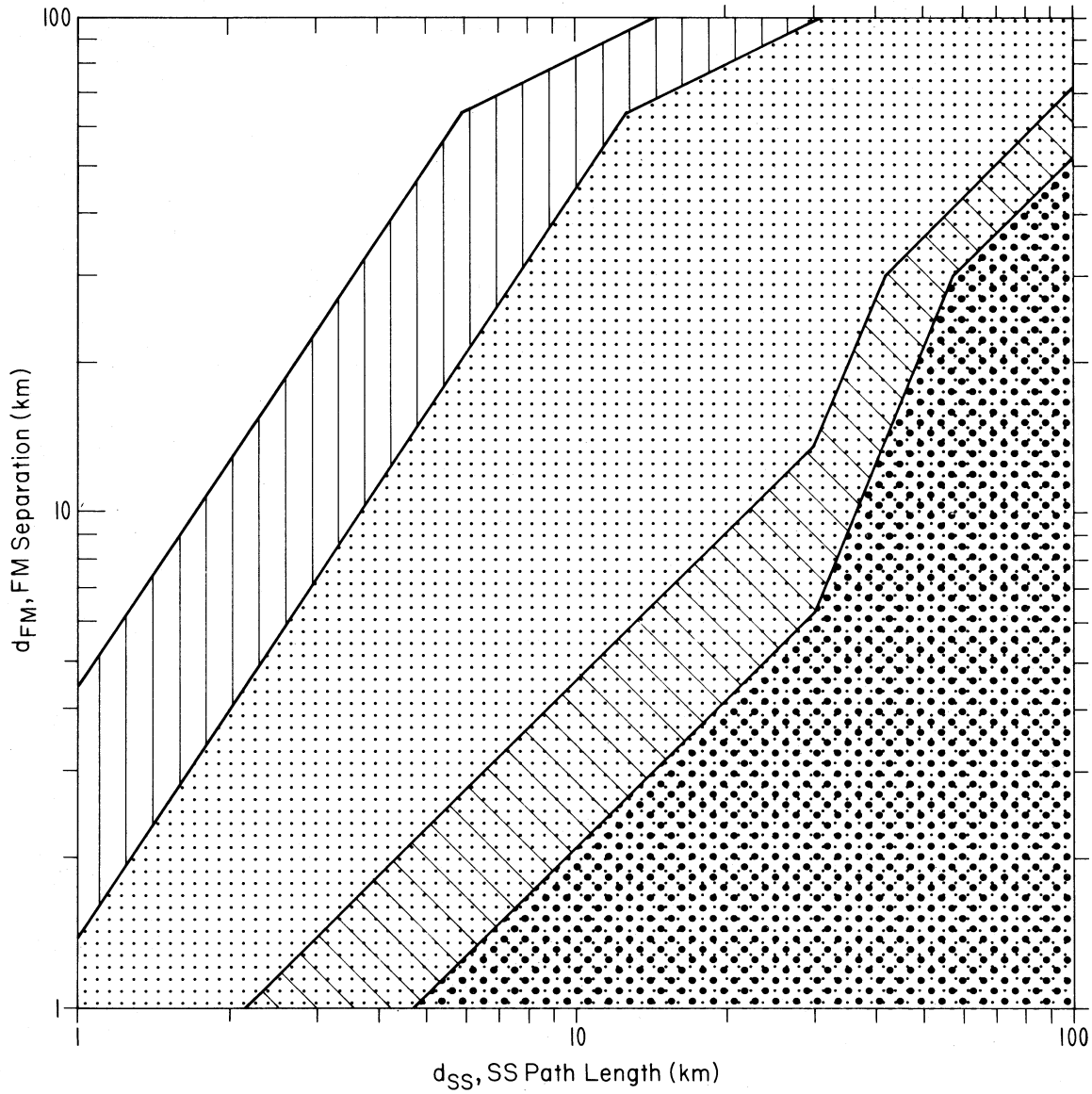





Figure 20. Separation distance d_{FM} versus d_{SS} that is required to insure $10 \text{ dB} \leq E_b/N_o \leq 20 \text{ dB}$, with $G_p = 30 \text{ dB}$, 900 MHz.

-  FM Base Interference to SS Base - Propagation Dependent
-  FM Base Interference to SS Base - Highly Probable
-  FM Base (Mobile) Interference to SS Mobile (Base) - Propagation Dependent
-  FM Base (Mobile) Interference to SS Mobile (Base) - Highly Probable

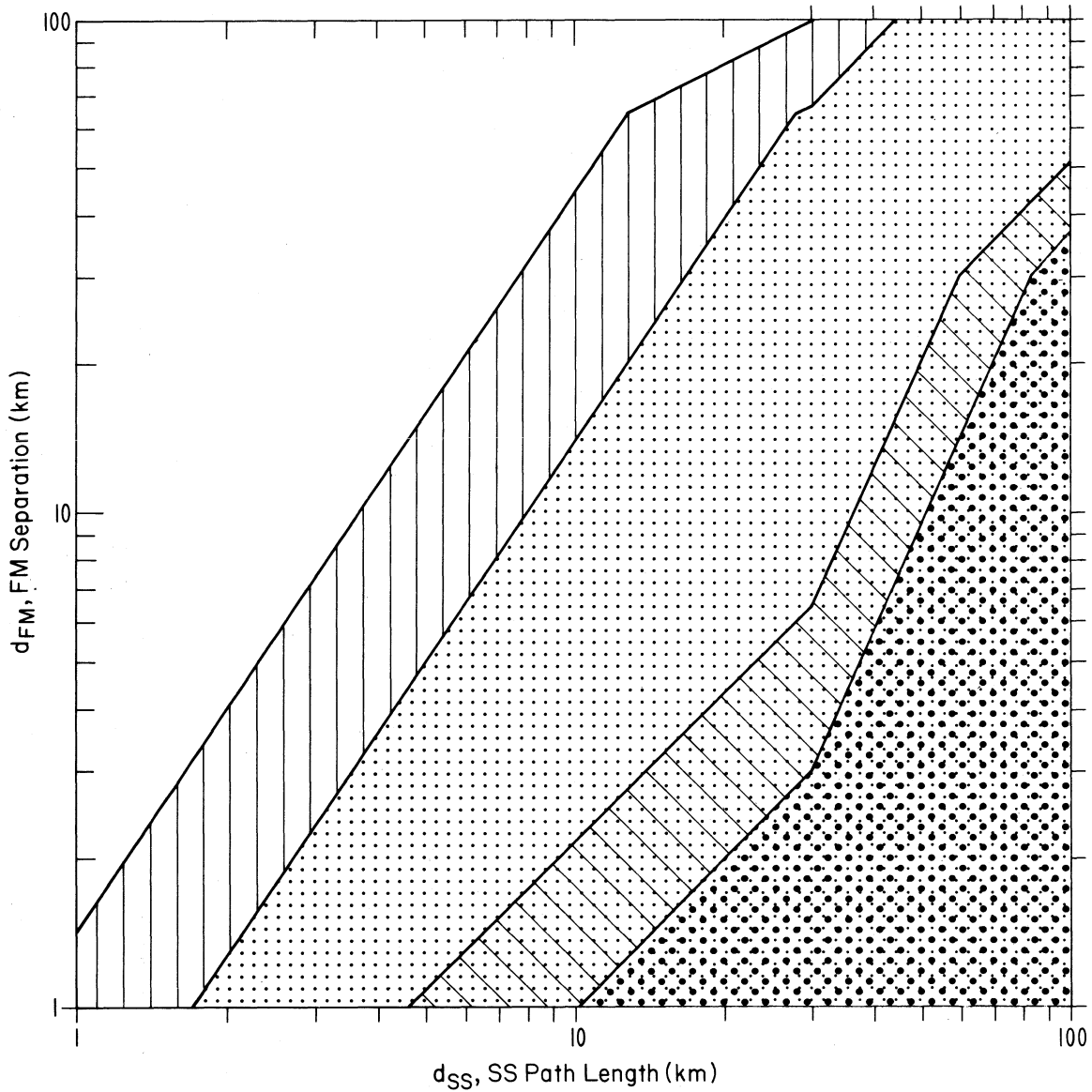

Figure 21. Separation distance d_{FM} versus d_{SS} that is required to insure $10 \text{ dB} \leq E_p/N_o \leq 20 \text{ dB}$, with $G_p = 40 \text{ dB}$, 900 MHz.

Table 8. Summary of Separation Distance, d_{FM} , that is Required to Insure $10 \text{ dB} \leq E_b/N_o \leq 20 \text{ dB}$ with $G_p = 30 \text{ dB}$

Interference	d_{SS} (km)	d_{FM} (km)	f (MHz)
FM Mobile to SS Base *	10	2-5	150
	30	6-14	150
FM Base to SS Base	10	27-70	150
	30	>82	150
FM Mobile to SS Base *	10	2-5	900
	30	6-14	900
FM Base to SS Base	10	45-82	900
	30	>100	900

Table 9. Summary of Separation Distance, d_{FM} , that is Required to Insure $10 \text{ dB} \leq E_b/N_o \leq 20 \text{ dB}$ with $G_p = 40 \text{ dB}$

Interference	d_{SS} (km)	d_{FM} (km)	f (MHz)
FM Mobile to SS Base *	10	1-2	150
	30	3-7	150
FM Base to SS Base	10	9-28	150
	30	46-82	150
FM Mobile to SS Base *	10	1-2	900
	30	3-7	900
FM Base to SS Base	10	14-45	900
	30	66-100	900

* Also applicable for an FM base interfering with an SS mobile.

With multiple interferers, the concept of separation distance d_{FM} becomes vague. For example, consider the case where there are ten interfering transmitters that are all located such that their separations satisfy the minimum requirements for d_{FM} . Although individually none of the transmitters singly would degrade performance, collectively their total power may be sufficient for interference. This situation is considered in this section with the aid of a Monte-Carlo, computer simulation program.

The geometry involved in the Monte-Carlo simulations is shown in Figure 22. Basically, the simulation model assumes that SS mobiles and interfering FM mobiles are randomly located throughout a circular service area of radius R . Interfering base stations, however, are restricted to the perimeter of this circle and are assumed to be randomly located around the outer perimeter. The reason that base stations are restricted to the perimeter is that we have already seen that base-to-base is a dominate source of interference. In fact it is easy to see from Tables 8 and 9 that one of the requirements to avoid base-to-base interference is that $d_{FM} > d_{SS}$. Thus, it is mandatory that FM base stations be located outside of the SS service area or unacceptable interference to the SS base will be very likely. The victim SS base station is assumed to be at the center of the service area.

A Monte-Carlo computer program simulates this model by randomly generating interfering and desired locations and computing the resulting interference. The probability density function for the interfering mobile distance is (Berry, 1978)

$$P(d_{FM}) = \frac{2}{R^2} d_{FM} \quad , \quad (36)$$

and the probability density function for the SS mobile distance is

$$P(d_{SS}) = \frac{2}{R^2} d_{SS} \quad . \quad (37)$$

The sequence used in the simulation program is:

- (a) simulate a single desired SS mobile distance d_{SS} as per (37),
- (b) simulate N_M interfering FM mobile distances d_{FM} as per (36),

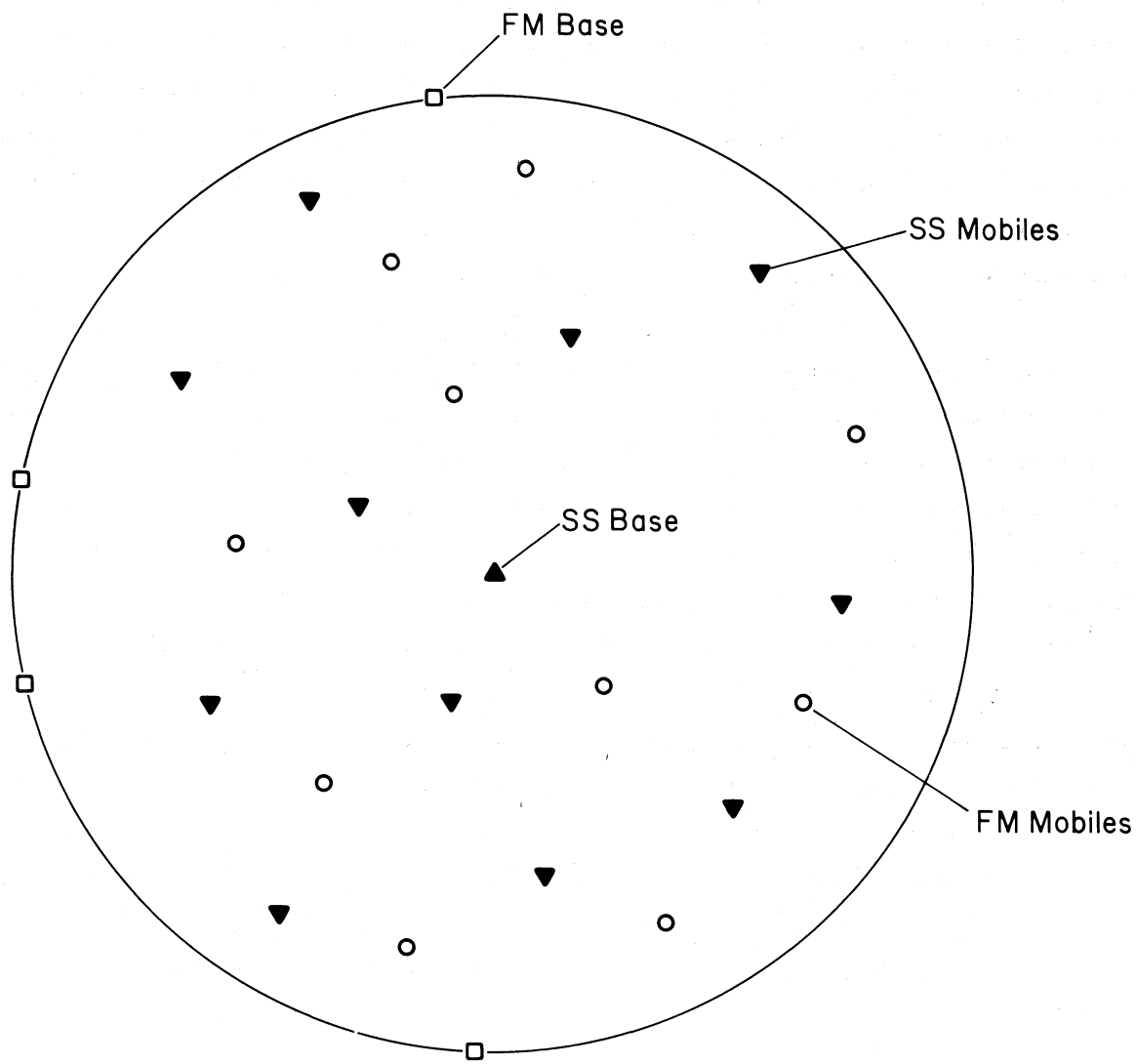

Figure 22. Geometry used in Monte-Carlo simulation.

- (c) simulate N_B base stations along the perimeter,
- (d) calculate the total interference power I_{TM} at the victim SS base from the N_M interfering FM mobiles,
- (e) calculate the total interference power I_{TB} at the SS base from the N_B interfering FM base locations,
- (f) the total interference power at the input to the SS base receiver is then $I_{IN} = I_{TM} + I_{TB}$,
- (g) calculate the resulting E_b/N_o , and
- (h) if E_b/N_o is less than required (curves are shown for both 10 and 20 dB), then consider the SS mobile as having been interfered with.

In order to keep the problem as simple as possible, it was decided that these preliminary estimates would be made with $R \leq 30$ km, which means that the distances are all within the radio horizon. Thus propagation equations (23) and (25) apply. The computer programs, however, can be easily extended to the case of over-the-horizon propagation.

The main output from the simulation program is f_i , which is the number of SS mobile transmissions that were interfered with divided by the total number examined. Figure 23 shows a plot of f_i for a $G_p = 30$ dB SS system with channel E_b/N_o requirements of 20 dB at 150 MHz. The symbols on the graph denote the actual simulation locations. One can see that in this instance the presence of one base station causes significant interference and, in fact, is worse than the interference encountered from 13 mobiles with no base stations. Results for the same system with reduced E_b/N_o requirements of 10 dB are shown in Figure 24. Here the addition of a single base station is not as severe. In fact, the reverse situation is true where increasing the number of simultaneous mobiles from 1 to 2 causes more interference than changing the number of base stations from 0 to 1. Figure 24 also applies for the $G_p = 40$ dB, $E_b/N_o = 20$ dB system, since the increased E_b/N_o requirements offset the additional performance obtained by the increase in processing gain. The last case, shown in Figure 25, is for the $G_p = 40$ dB, $E_b/N_o = 10$ dB case. With this situation, the effect of the interfering base stations is minimal. In fact one can add five base stations with only minor increases in interference.

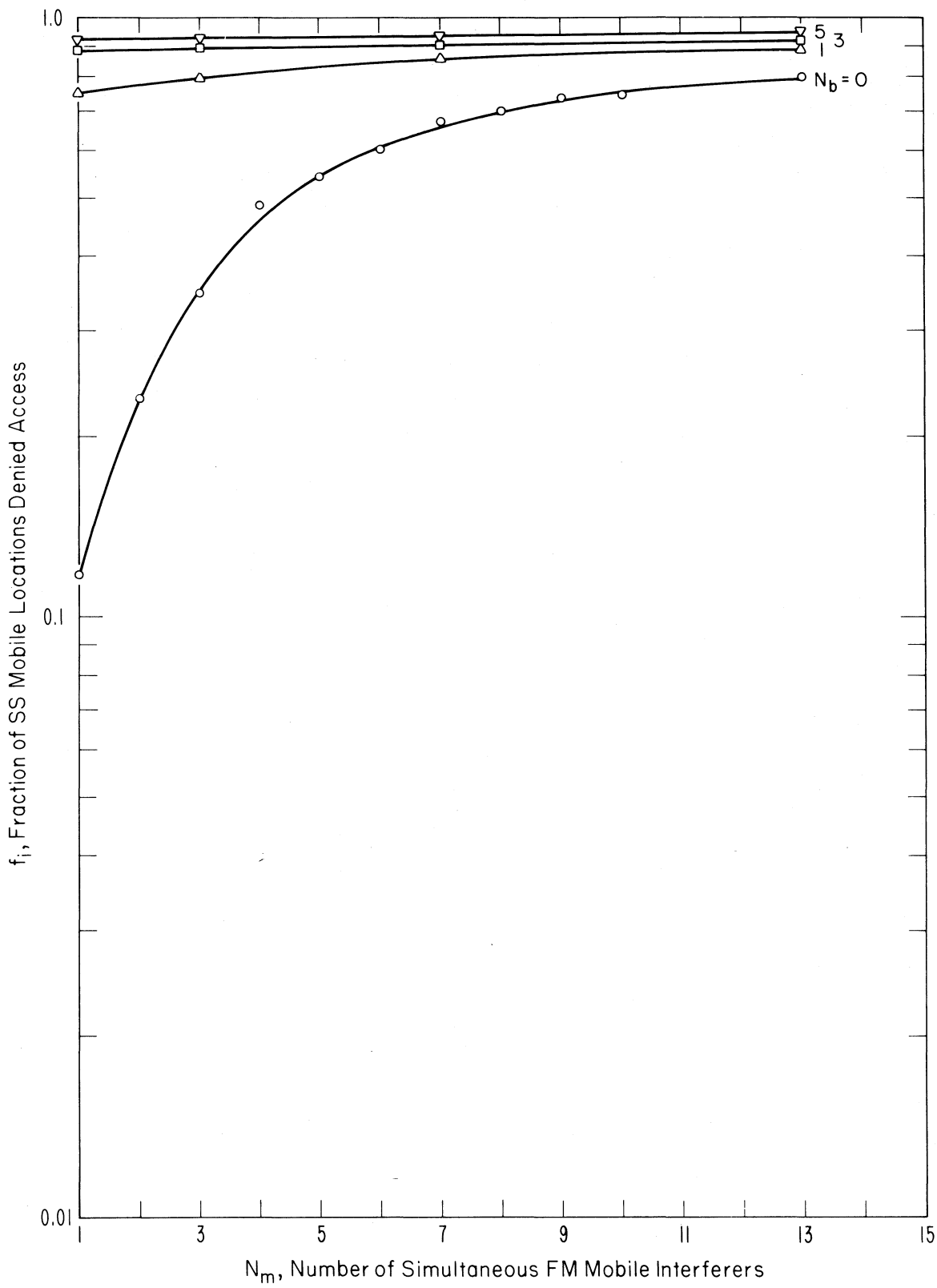

Figure 23. Monte-Carlo simulation results for an SS system with $G_p = 30$ dB and E_b/N_o requirements of 20 dB at 150 MHz.

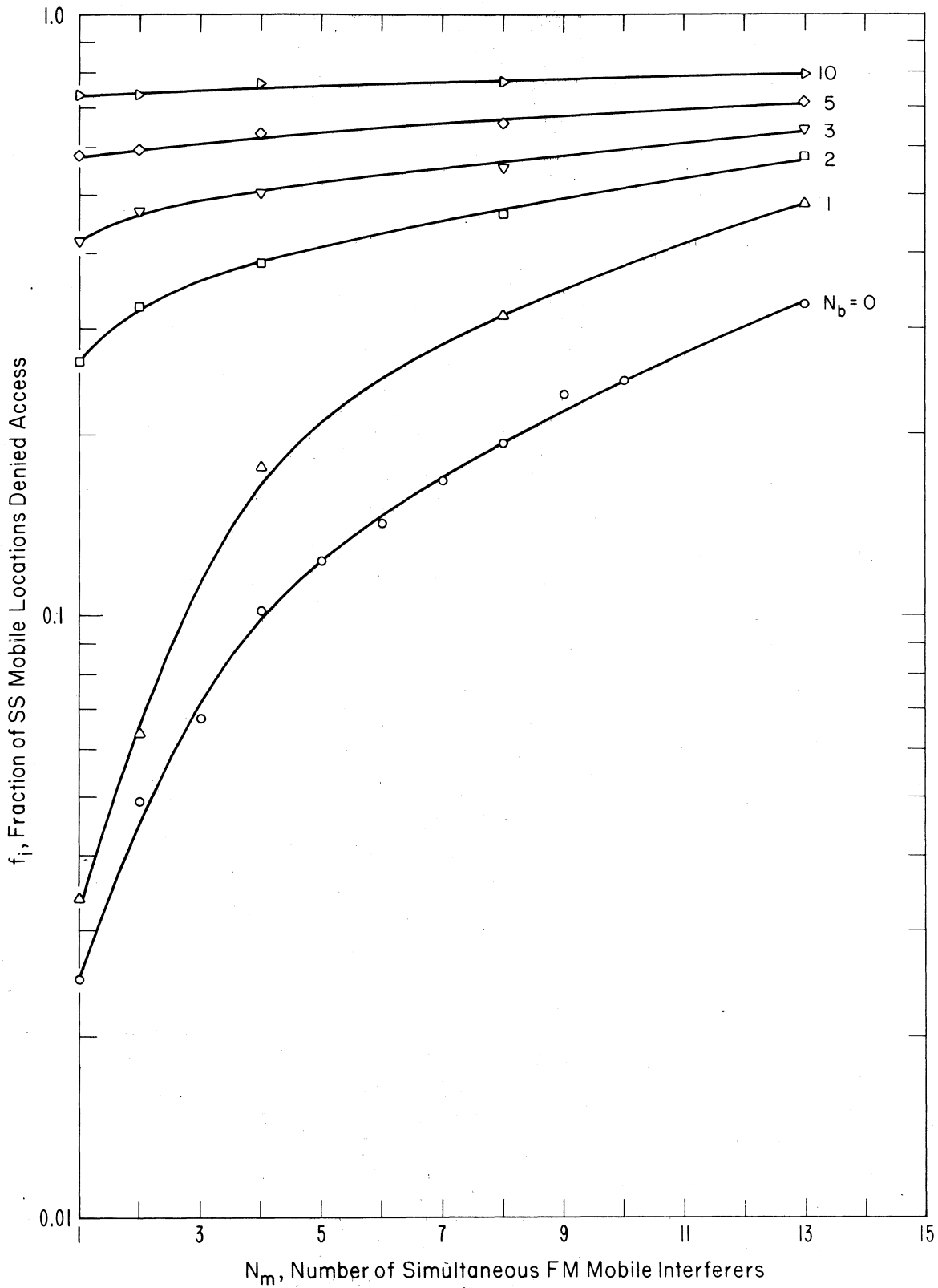

Figure 24. Monte-Carlo simulation results for an SS system with $G_p = 30$ dB and $E_b/N_o = 10$ dB. The results also apply for a $G_p = 40$ dB system with E_b/N_o requirements of 20 dB at 150 MHz.

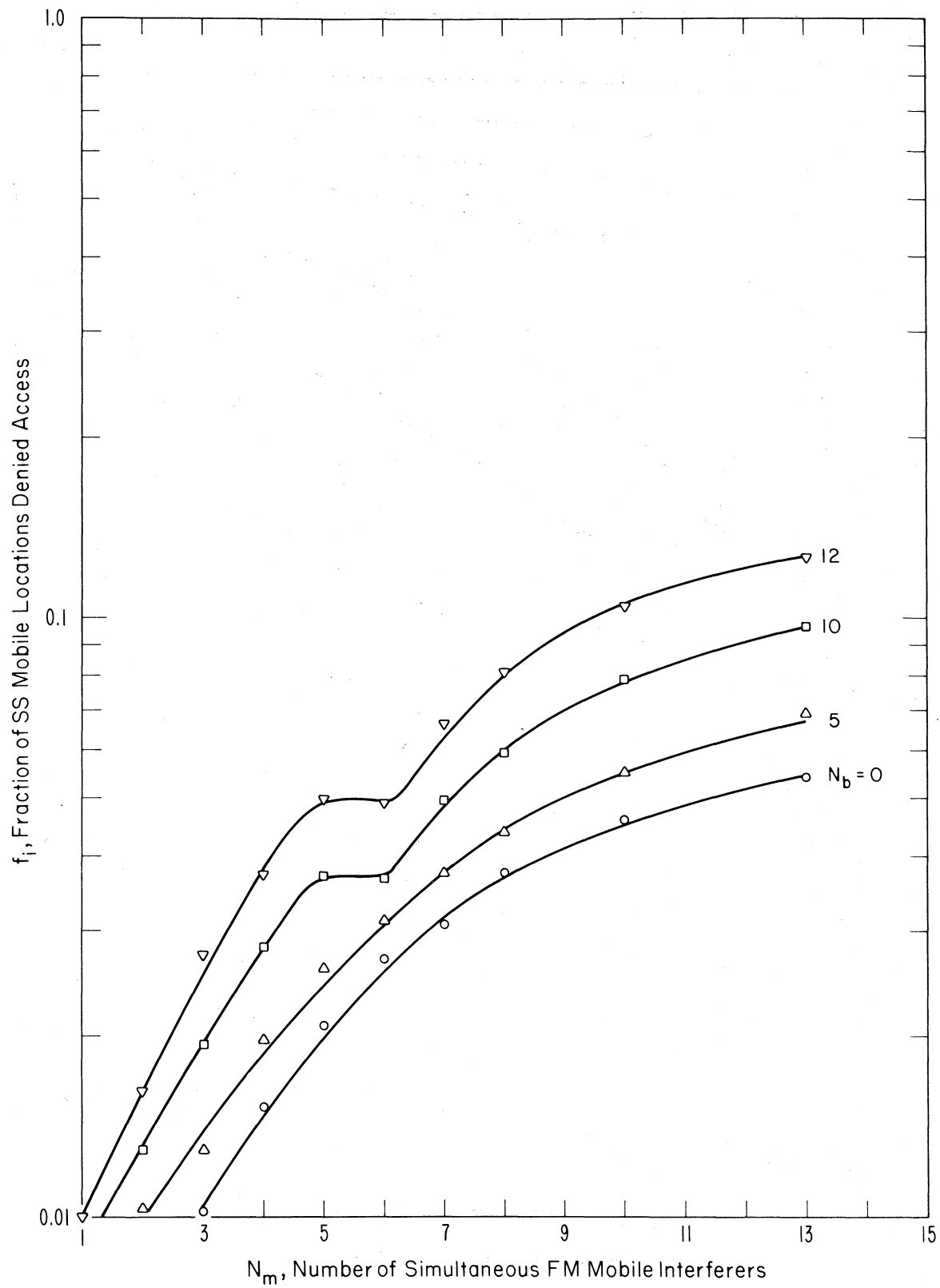

Figure 25. Monte-Carlo simulation results for an SS system with $G_p = 40$ dB and E_b/N_o requirements of 10 dB at 150 MHz.

These results can be summarized by stating that, with a marginal SS system ($f_i > 0.1$ with $N_m = 1$ and $N_B = 0$), the addition of a single base station can have a significant effect. This is not true however with the nonmarginal system where the increase in f_i due to a single interfering base is negligible. Table 10 summarizes these results by listing f_i for various N_m and N_B . It is important to remember that the different multipath conditions accounts for the $10 \text{ dB} \leq E_b/N_o \leq 20 \text{ dB}$ range.

Table 10. Summary of Monte Carlo Simulation Program where f_i is the Fraction of SS Mobiles Denied Access in the Circular Urban Model

G_p (dB)	N_m	N_B	f_i	
			$E_b/N_o = 10 \text{ dB}$	$E_b/N_o = 20 \text{ dB}$
30	1	0	.025	.120
30	5	0	.140	.480
30	5	5	.210	.940
30	10	5	.760	.960
30	10	10	.780	~1
40	1	0	<.010	.025
40	5	0	.020	.140
40	5	5	.026	.210
40	10	5	.037	.760
40	10	10	.078	.780

8. FM SQUELCH THRESHOLD

Our definition of interference to FM so far has been based strictly on output signal-to-noise ratio. However, other situations also exist that should be examined. For example, consider the case of an FM mobile receiver that breaks squelch every time an SS transmitter is keyed. The FM user might consider this as interference even though he can still intelligibly receive his FM base.

This situation was investigated with the results shown in Figures 26 and 27. Plotted here is the separation d_{th} between an SS transmitter and FM receiver that is necessary in order to avoid exceeding the FM squelch threshold. The level of this threshold with a cw input is assumed to be $0.1 \mu V$ in 50 ohms or -157 dBW. Figure 26 is for a frequency of 150 MHz while Figure 27 shows the results for 900 MHz. It is assumed that the receivers are designed so that the squelch is affected only by that portion of the SS signal that passes through the IF filter. This means that the squelch threshold will be exceeded when

$$ERP_{SS} - L(d_{th}) + A_{FM-R} - 10 \log \frac{b_{SS}}{b_{IF}} > -157 \text{ dBW} \quad , \quad (38)$$

where ERP_{SS} is the effective radiated power of the SS transmitter, $L(d_{th})$ is the path loss over the distance d_{th} , and A_{FM-R} is the FM receiver antenna gain. The quantities b_{IF} and b_{SS} are the FM receiver bandwidth and SS RF bandwidth, respectively. For these calculations, the values of $A_{FM-R} = 0$ dB and $b_{IF} = 25$ kHz were used. As can be seen, considerable separation distances are required to avoid exceeding squelch threshold even with b_{SS} as large as 10 MHz.

9. ADDITIONAL FH SUPPRESSION

So far the possibility of spectrum sharing between FM and SS systems appears to be bleak. As shown in Table 8, values of $d_{SS} = 10$ km imply that, at best, $d_{FM} > 2$ km in order to avoid interference from FM mobiles. Interference from SS base stations is even worse as separations greater than 27 km are required at 150 MHz.

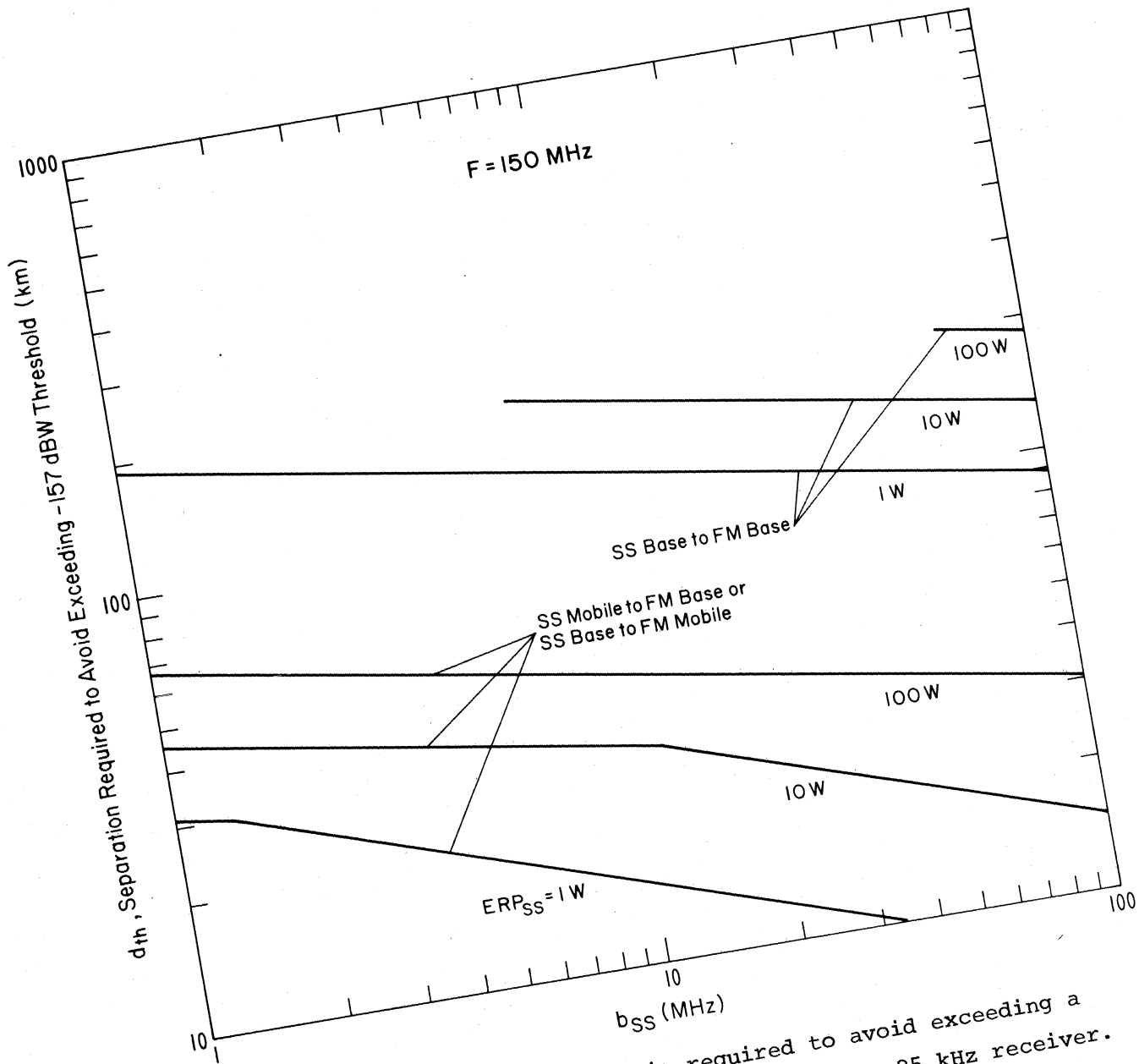

Figure 26. Separation d_{th} that is required to avoid exceeding a -157 dBW squelch threshold on a $b_{IF} = 25$ kHz receiver. Frequency is 150 MHz.

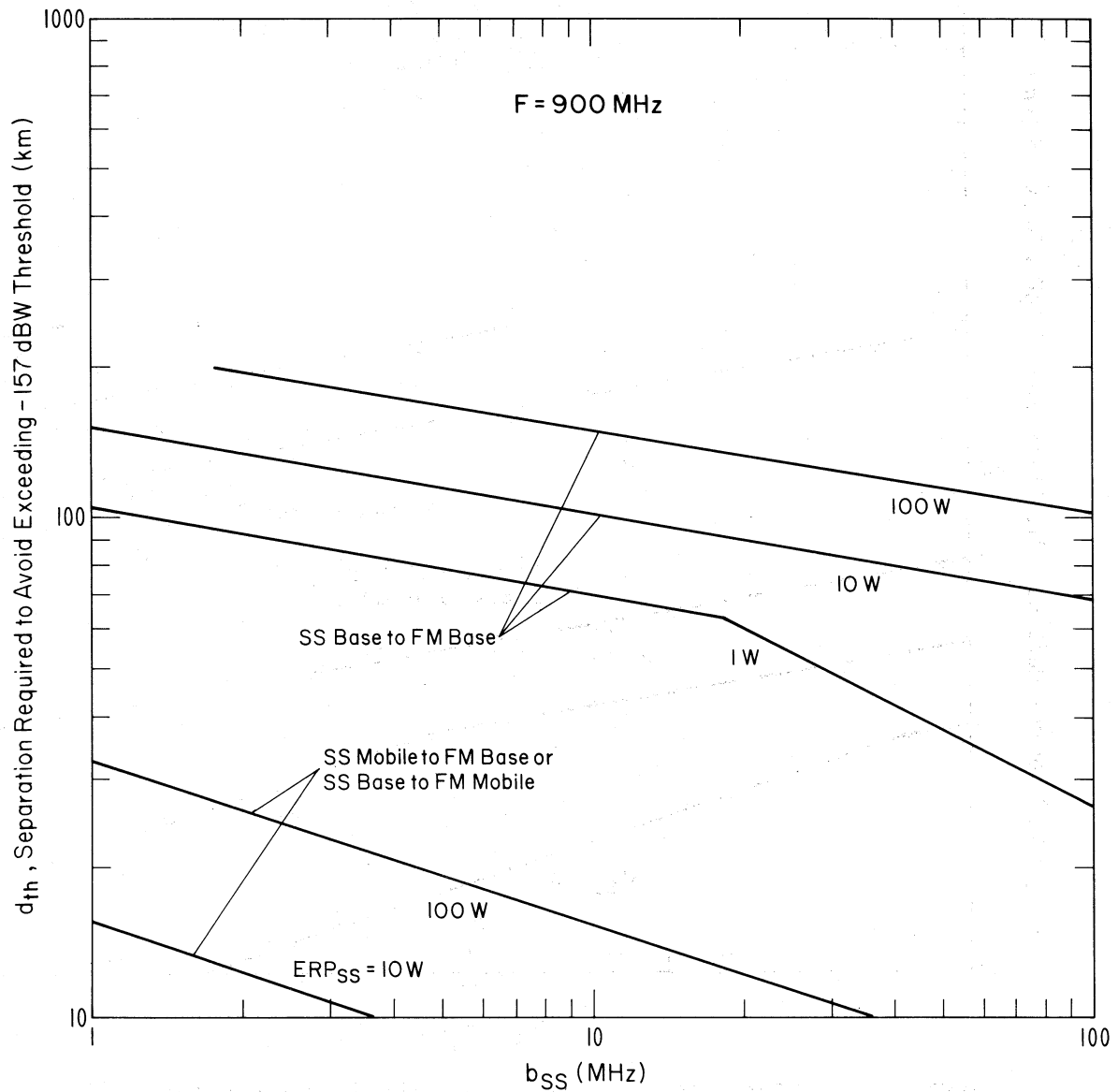

Figure 27. Separation d_{th} that is required to avoid exceeding a -157 dBW squelch threshold on a $b_{IF} = 25$ kHz receiver. Frequency is 900 MHz.

With frequency-hopping systems there is an additional possibility for avoiding interference if the frequency controller can be programmed to avoid those FM channels that are in use in any given locality. The fact that a frequency is missing does not necessarily mean that no energy will be radiated in this 25 kHz channel, but only that it will be reduced. The exact amount of reduction that can be expected in a 25 kHz channel is dependent on the FH signal design and is determined by tradeoffs such as the hopping pattern, filter requirements, and equipment costs.

Figures 28(a) and (b) show the spectrum of a frequency hopper with and without a missing frequency. These photographs were obtained by looking at the spectrum of a programmable signal generator whose frequency-hopping sequence could be programmed to miss a given frequency. The gap in Figure 28(b) is approximately 30 kHz wide at the 3 dB points and is only intended as an example of what might be expected. The characteristics of the notch could be sharper with proper design and filtering. This technique provides a method for "reclaiming" spectrum that is not used in a particular area or spectrum that is in use outside of the immediate service area.

Figures 29 and 30 show the separation distance d_{SS} versus d_{FM} that would be required assuming an additional 30 dB suppression due to frequency hopping. Comparing these figures with Figures 13 and 14, one can see that a significant improvement has been achieved.

10. CONCLUSIONS

The conclusion of this report is that it would be impossible to overlay a new spread-spectrum LMR system into a frequency band already occupied by existing FM systems without causing interference. The definition of overlay here has been interpreted as meaning the unrestricted operation of both SS and FM mobiles throughout the same service area. This conclusion results from the fact that the reduction in interference obtained by spectrum spreading is not sufficient to overcome the extreme range of propagation conditions encountered in an LMR environment.

The reduction in interference obtained by spectrum spreading has been shown to be determined by b_{SS}/b_{IF} . For a $b_{SS} = 1$ MHz spread-spectrum system, this amounts to 16 to 20 dB depending on the value of b_{IF} (25 or 10 kHz, respectively). Although this reduction is of some benefit, it is not sufficient to compensate for the wide range of signal conditions that can be

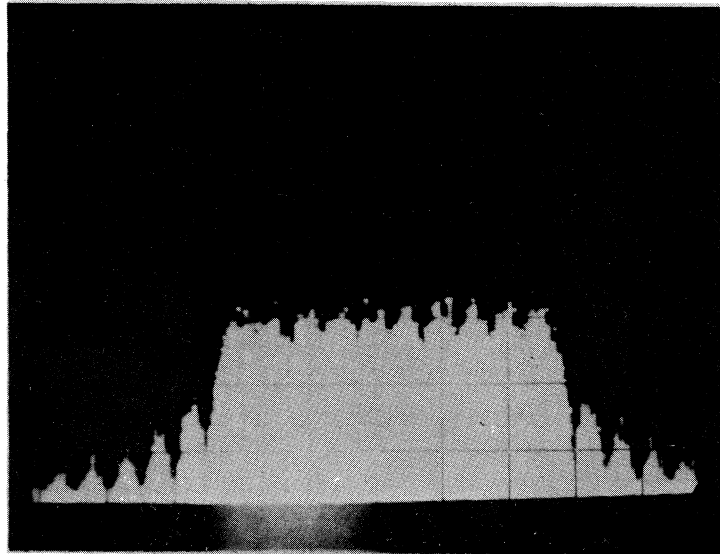

→ | | ← 100 kHz



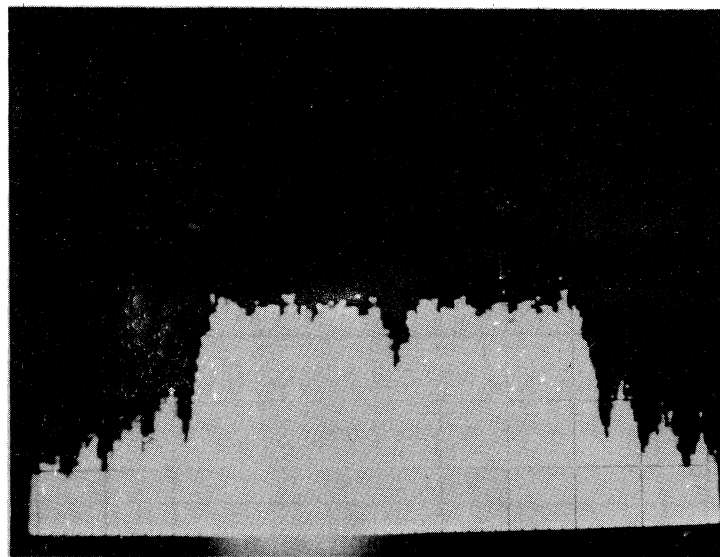

(a)



→ | | ← 100 kHz

(b)

Figure 28. Example of a frequency hopper with (a) all frequencies present and (b) a missed frequency.

-  SS Base Interference to FM Base - Propagation Dependent
-  SS Base Interference to FM Base - Highly Probable
-  SS Base (Mobile) Interference to FM Mobile (Base) - Propagation Dependent
-  SS Base (Mobile) Interference to FM Mobile (Base) - Highly Probable

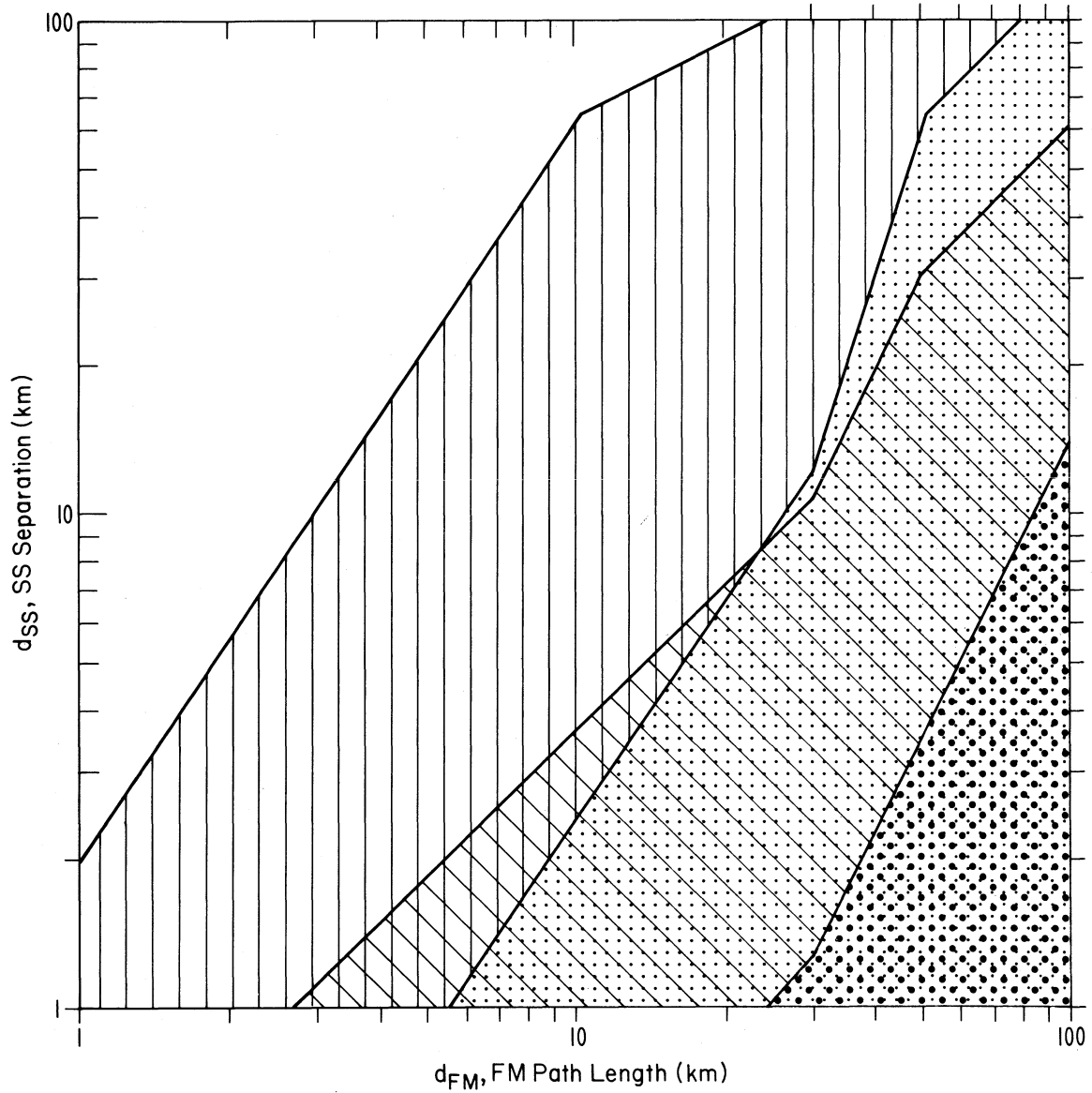





Figure 29. Separation distance d_{SS} versus d_{FM} that is required to insure $S/I_{OUT} > 20$ dB with a 1 MHz SS system at 150 MHz. Assumes additional 30 dB suppression due to FH pattern.

-  SS Base Interference to FM Base - Propagation Dependent
-  SS Base Interference to FM Base - Highly Probable
-  SS Base (Mobile) Interference to FM Mobile (Base) - Propagation Dependent
-  SS Base (Mobile) Interference to FM Mobile (Base) - Highly Probable

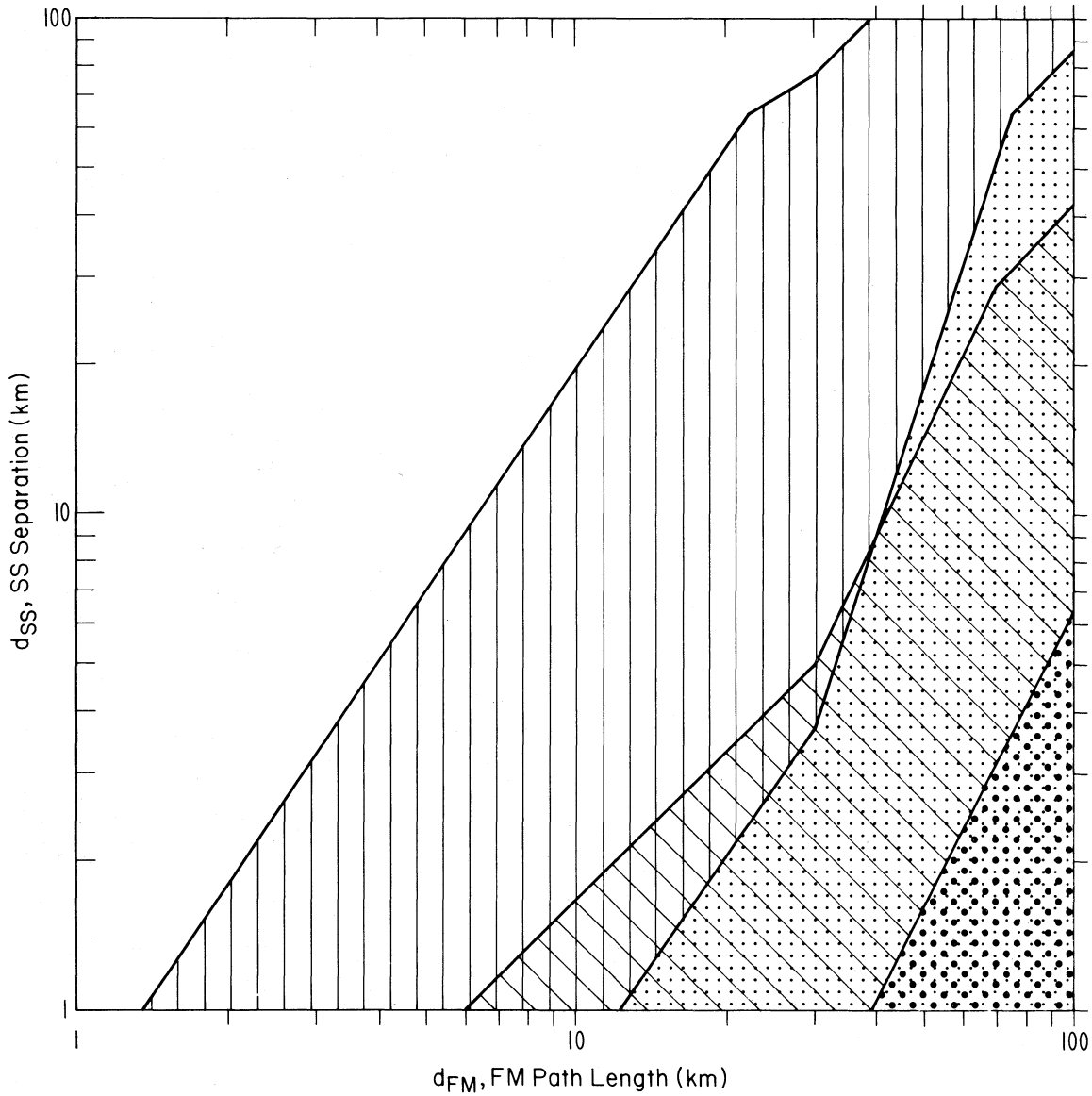

Figure 30. Separation distance d_{SS} versus d_{FM} that is required to insure $S/I_{OUT} > 20$ dB with a 10 MHz SS system at 150 MHz. Assumes additional 30 dB suppression due to FH pattern.

expected in an LMR environment. The problem is only compounded when one considers the possibility of interference from an SS base to an FM base where free space propagation conditions can exist.

The report has estimated the separation distance, d_{SS} , that is required to protect an FM system transmitting over a path of distance d_{FM} . Some examples of these estimates for a $b_{SS} = 1$ MHz system at 150 MHz are as follows:

- | | |
|---|--|
| (a) SS mobile interfering with an FM base | $d_{FM} = 10$ km,
$d_{SS} = 4 - 22$ km; |
| (b) SS base interfering with an FM base | $d_{FM} = 10$ km,
$d_{SS} > 64$ km. |

These estimates are only slightly reduced for a $b_{SS} = 10$ MHz system where

- | | |
|---|--|
| (a) SS mobile interfering with an FM base | $d_{FM} = 10$ km,
$d_{SS} = 2 - 15$ km; |
| (b) SS base interfering with an FM base | $d_{FM} = 10$ km,
$d_{SS} > 22$ km. |

The variability in d_{SS} corresponds to different fading margins for different propagation channels. The lower figure is for a fading margin of $M_F = 0$ dB, while the larger is for $M_F = 29$ dB.

A second problem that is encountered is the effect that an SS transmitter would have on the squelch of an FM receiver. For example, it is estimated that the separation distance d_{th} between an SS mobile and FM base that would be necessary to avoid exceeding a -157 dBW FM squelch threshold (0.1 μ V in 50 ohms) is:

- | | |
|--|-------------------|
| (a) SS mobile with $b_{SS} = 1$ MHz
ERP _{SS} = 10 W | $d_{th} = 45$ km |
| (b) SS mobile with $b_{SS} = 10$ MHz
ERP _{SS} = 10 W | $d_{th} = 31$ km. |

The reverse situation of interference from FM to SS systems is only marginally better at best. For this situation, d_{FM} now becomes the required separation distance while d_{SS} is the victim SS transmission path distance. The corresponding separation requirements at 150 MHz are:

- | | |
|--|---|
| (a) FM mobile interfering with a $G_p = 30$ dB SS base station | $d_{SS} = 10$ km,
$d_{FM} = 2 - 5$ km; |
| (b) FM mobile interfering with a $G_p = 40$ dB SS base station | $d_{SS} = 10$ km,
$d_{FM} = 1 - 2$ km; |
| (c) FM base interfering with a $G_p = 30$ dB SS base station | $d_{SS} = 10$ km,
$d_{FM} = 27 - 70$ km; |
| (d) FM base interfering with a $G_p = 40$ dB SS base station | $d_{SS} = 10$ km,
$d_{FM} = 9 - 28$ km. |

These estimates are for the case of a single FM interferer.

An SS receiver, however, can be expected to see multiple FM interferers because of its wide bandwidth. The multiple interference situation is examined with a Monte-Carlo, computer simulation program. The parameter used to measure interference in this case is f_i , which is the fraction of SS mobile locations denied access within a circular service area. These SS mobile and interfering FM mobiles are assumed to be randomly located throughout the circular service area. Interfering FM base stations are also included in the simulation program, but are restricted to operation at the outer perimeter of the SS service area. This restriction was imposed since excessive levels of interference from an FM base to SS base were encountered unless steps were taken to insure that the FM base station was outside of the SS service area.

Results of the simulation program are shown in the following where N_m represents the number of simultaneous interfering FM mobiles and N_B represents the number of simultaneously interfering FM base stations:

- (a) SS system with $G_p = 30$ dB
- | | |
|---------------------|-----------------------------|
| $N_m = 1, N_B = 0,$ | $0.025 \leq f_i \leq 0.120$ |
| $N_m = 5, N_B = 0,$ | $0.140 \leq f_i \leq 0.480$ |
| $N_m = 5, N_B = 5,$ | $0.210 \leq f_i \leq 0.940$ |

(b) SS system with $G_p = 40$ dB

$$N_m = 1, N_B = 0, 0.010 \leq f_i \leq 0.025$$

$$N_m = 5, N_B = 0, 0.020 \leq f_i \leq 0.140$$

$$N_m = 5, N_B = 5, 0.026 \leq f_i \leq 0.210 .$$

The range of f_i corresponds to the requirements that $10 \leq E_p/N_o \leq 20$ dB to account for the various multipath conditions that might be expected in an urban channel. These results lead to the conclusion that the SS system will also receive significant levels of interference with unrestricted operation in frequency bands already occupied by existing FM systems.

One type of SS system that appears to have significant promise is an FH system that is programmed to avoid frequency channels already in use in a given locality. With proper design, this type of system could essentially achieve the signal suppression necessary for unrestricted operation. The frequency avoidance method is essentially a method of reclaiming unused spectrum or spectrum used outside of the immediate service area.

It is also interesting to compare the conclusions of this report with those achieved in an independent study (Dvorak, 1978). This study which also examines the compatibility of spread-spectrum signals with narrowband FM receivers in VHF mobile networks concludes the following:

"It follows from the preceding that the compatibility of even a single SS transmitter with a power comparable to the levels currently used in present VHF mobile communication would be difficult to achieve. Although the SS interference may remain unidentified, because of its noise-like character, receiver threshold sensitivity will be reduced up to relatively large distances around the SS transmitter. With diminishing separation, the amplitude of interference will increase approximately to a $1/d^{2.5}$ -law so that reception of all but the strongest signals would soon become impossible. Especially in mountainous terrain the linear dependence of the interfering signal on the effective height of the interferer's antenna may contribute to an accelerated onset of these effects."

Numerous assumptions have been used throughout this report. Although arguments can undoubtedly be made for and against these assumptions, it is doubtful that the conclusions would be significantly altered. Some of the major assumptions are that the transmitter powers of the SS and FM systems are comparable. The only instance where the transmitter powers are apt to be drastically different is if the SS system were implemented using the cellular

concept. The cellular concept was not analyzed in this limited study. Other major assumptions are that the base station antenna heights are 200 m with mobile antenna heights of 1.5 m. This, in turn, leads to the propagation models described in (23) through (26). Another assumption is that the increase in FM receiver output noise can range from $M_f = 0$ for a nonfading channel to $M_f = 29$ dB in a Rayleigh fading channel.

A major unknown, which was encountered during the preparation of this report, is the effect of FH interference on FM receivers. While it is known that FH interference will have pulse characteristics at slow hopping rates, it is not known what effect this has on intelligibility. Also, information on the effects of fading on the interference portion of the received signal is lacking. A third area where information is lacking is the behavior of SS systems in the urban multipath channel. A particular intriguing prospect is the fact that SS transmission can effectively combat multipath to some extent. This study has used the values $10 \text{ dB} \leq E_b/N_o \leq 20 \text{ dB}$ to allow for the unknowns in system design and channel propagation conditions.

11. REFERENCES

- Berry, L. A. (1978), Spectrum efficiency for multiple independent spread-spectrum land mobile radio systems, NTIA Report 78-11, U.S. Department of Commerce, National Telecommunications and Information Administration, November.
- Cahn, C. R. (1973), Spread spectrum applications and state-of-the-art equipments, AGARD Lecture Series No. 58, NATO Advisory Group for Aerospace Research and Development, pp. 5-1 through 5-111. (NTIS, Springfield, VA 22161, Accession No. AD-766914).
- Cline, R. W. (1973), Pseudo random modulation--an effective means of enhancing PSK signal transmission in a diffuse multipath environment, 25th Annual Southwest IEEE Conference and Exhibition, Houston, Texas, April, pp. 312-317.
- Cooper, G. R., and R. W. Nettleton (1976), Efficient spectrum utilization with wideband signals, Final Report TR-EE 77-12, School of Electrical Engineering, Purdue University, W. Lafayette, Indiana.
- Davies, N. C. (1973), Spread spectrum communications, performance and synchronization considerations, AGARD Lecture Series No. 58, NATO Advisory Group for Aerospace Research and Development, pp. 4-1 through 4-24 (NTIS, Springfield, VA 22161, Accession No. AD-766914).
- Dixon, R. C. (1976), Spread Spectrum Systems (John Wiley & Sons, New York).

- Dvorak, T. (1978), Compatibility of spread-spectrum signals with narrowband FM receivers in VHF mobile networks, IEEE Symposium on EMC, Atlanta, Georgia, pp. 19-23.
- Hernandez, Arecio A. (1975), Investigation of pulsed interference to narrowband FM receivers, ESD-TR-75-023, U.S. Dept. of Defense, Electromagnetic Compatibility Analysis Center, Annapolis, Md.
- Kullstam, P. A. (1977), Spread spectrum performance analysis in arbitrary interference, IEEE Trans. on Communications, COM-25, No. 8, pp. 848-853.
- Park, J. H., Jr., and C. Chayaradhanangkur (1977), Effect of fading on FM reception with cochannel interference, IEEE Trans. on Aerospace and Electronic Systems, AES-13, No. 2, March, pp. 127-132.
- Pettit, Ray H. (1977), On the use of "processing-gain" as a performance-measure for spread spectrum systems, IEEE Southeast Conference Record, Atlanta, Georgia, pp. 185-188.
- Stein, Seymour, and J. J. Jones (1967), Modern Communication Principles (McGraw-Hill, New York), p. 180.



APPENDIX. COOPER-NETTLETON SYSTEM PARAMETERS

1. System Description

The purpose of this appendix is to review and summarize the system design parameters that were used by Cooper and Nettleton in their proposal for a spread-spectrum, land-mobile communication system (Cooper and Nettleton, 1976). The system they propose is basically a frequency hopped, time encoded system that transmits a signal such as the one depicted in Figure A-1. As can be seen, the signal is composed of m time slots of duration $1/t_1$ and m frequency slots of width f_1 Hz. The equation for the k th signal waveform during the i th time slot (or i th chip) is

$$s_i^k(t) = c_i^k \sqrt{2S} \cos 2\pi (f_0 + a_i^k f_1 + \theta_i) \quad i t_1 \leq t \leq (i+1) t_1 \quad (1)$$

Here we use $c_i^k = \pm 1$ to represent the transmitted digital message, S the signal power, and a_i^k the frequency-hopping pattern. It is important to note that this system considers the possibility of "overlapping frequency slots." Since the spectrum requirements are inversely proportional to the chip period t_1 , overlapping frequency slots will occur if

$$f_1 < \frac{1}{t_1} \quad (2)$$

The term θ_i is a phase term that is added to the waveform to insure a continuous phase at the chip boundaries for the overlapping case and is not needed if $f_1 = 1/t_1$. The spectrum of this signal is approximately uniform with bandwidth

$$B \approx \frac{m}{t_1} \quad (3)$$

In order to accommodate more users, the preceding code set is subdivided by partitioning it into subsets of length n where $n < m$. The subdivided code is the code that is being described in the remainder of this appendix. Note that the spectrum required by the system still remains at m/t_1 . This is due to the fact that even though a particular user requires only n frequency

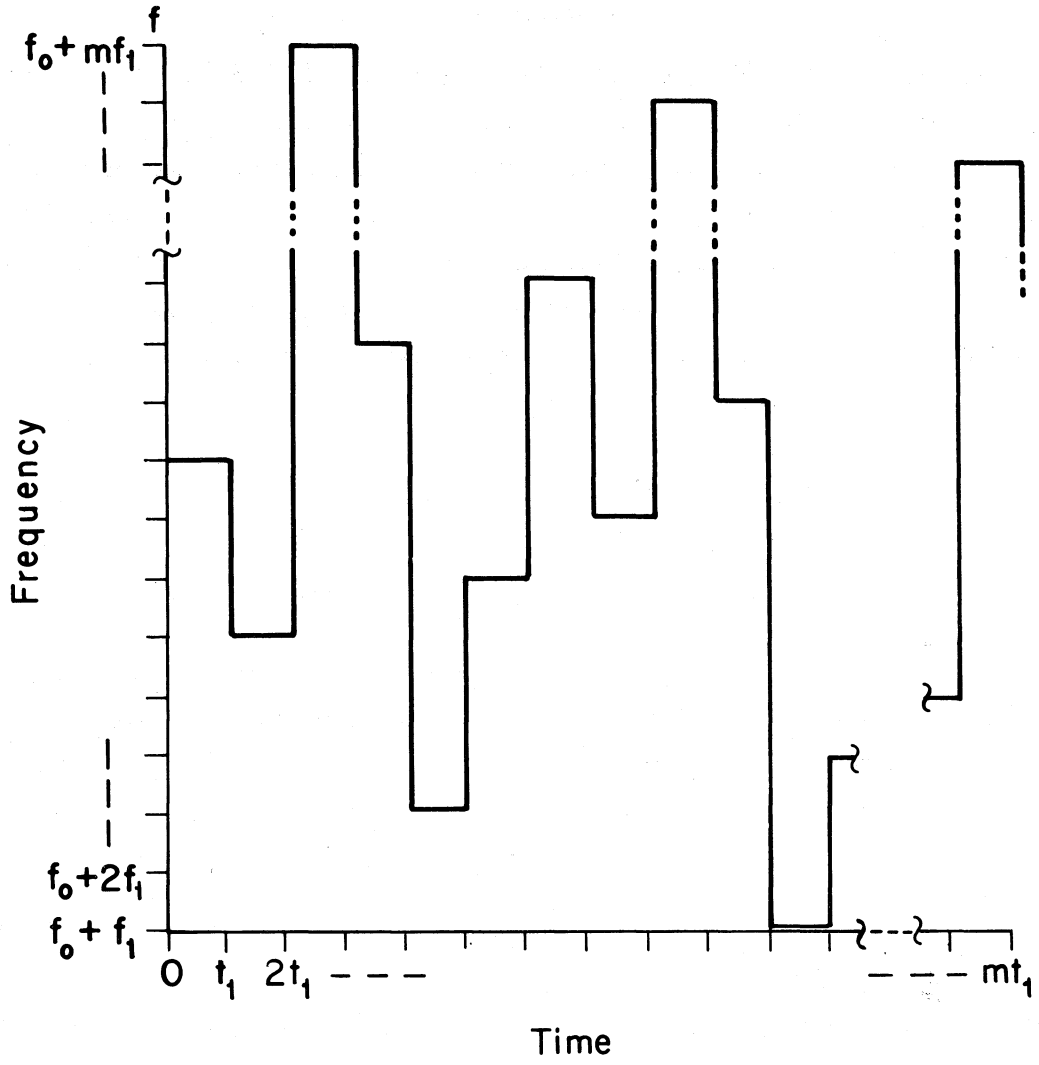

Figure A-1. Typical frequency-hopped, time-encoded signal.

slots, other users will be designed different slots; and hence, in general, all m frequency slots will be used.

So far we have not discussed how the digitized voice is impressed on the code set. In the proposed system, M -ary signalling is used where each user encodes $k = \log_2 n$ information bits into the n chip waveform. This means that n possible waveforms, n chips in length, must be decoded by each user with each waveform yielding k decoded information bits. Details of the decoder are shown in Figure A-2. The delay, T , shown on each of the taps in Figure A-2, makes the detector differentially coherent. This technique enables a comparison to be made of the phase of the i th chip with the phase of its predecessor that arrived $T = n t_1$ seconds earlier.

Some of the other parameters and expressions that are pertinent are shown in the following summary:

Voice Digitizing Rate $R_1 = 48,000$ bits/sec.

Number of chips per code $n = 32$ or 64 .

M -ary information bits per code $k = \log_2 n = 5$ or 6 .

Code period $T = n t_1 = 104 \mu\text{sec}$ ($n = 32$).

$$\begin{aligned} \text{Equivalent noise bandwidth of 1 chip } B_1 &= \frac{R_1 n}{\log_2 n} = \frac{1}{t_1} \\ &= 307.2 \text{ kHz } (n = 32) \end{aligned}$$

$$\begin{aligned} \text{Receiver equivalent noise bandwidth} &= \frac{n}{t_1} \\ &= 9.83 \text{ MHz } (n = 32). \end{aligned}$$

$$\text{Available system bandwidth } B = \frac{m}{t_1} = 40 \text{ MHz.}$$

$$\text{Total number of system codes } N_c \cong \frac{m^2}{n}.$$

$$\text{Total number of frequency slots } m = \frac{B}{B_1 f_1 t_1}.$$

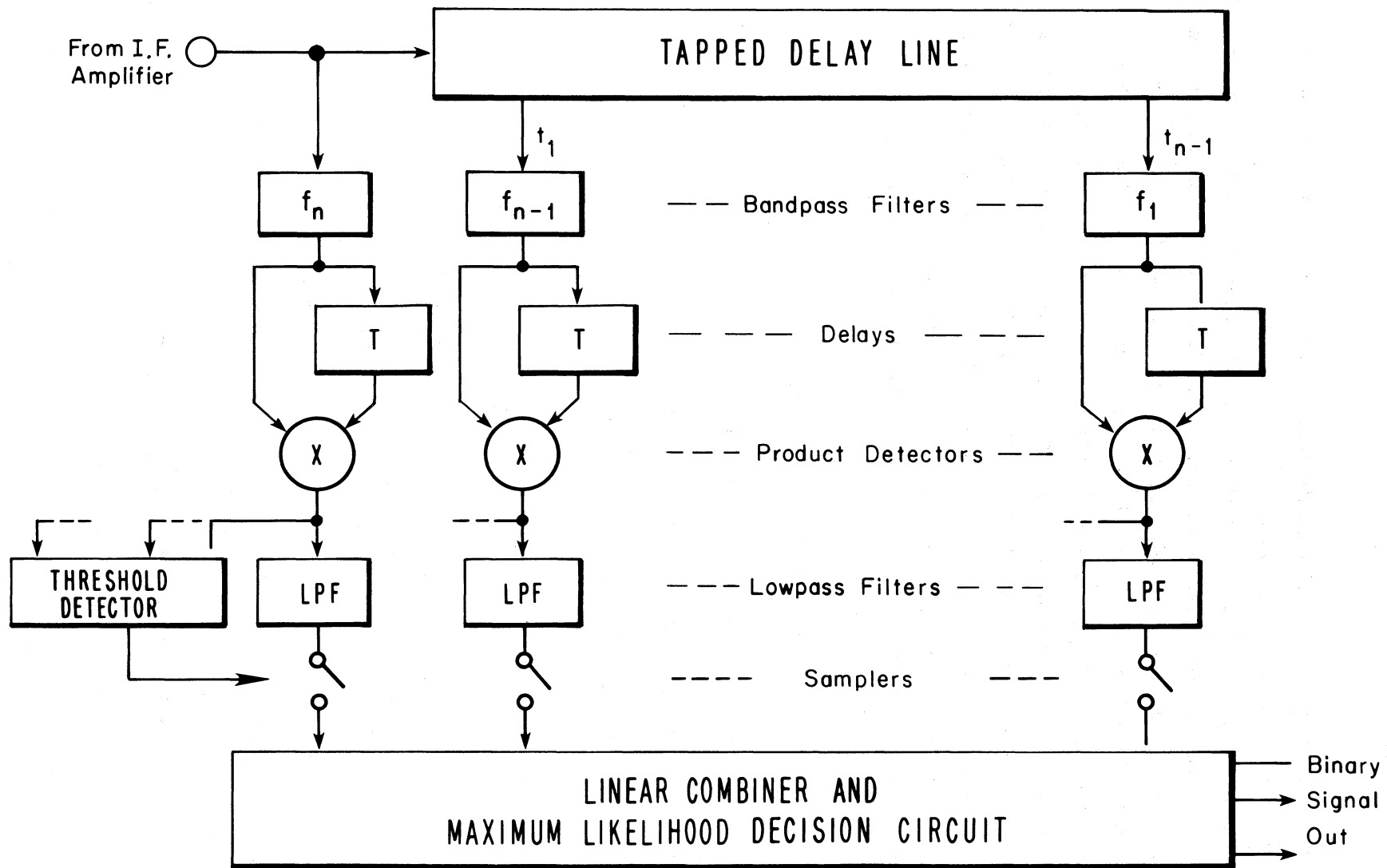

Figure A-2. Proposed decoder.

Typical values for N_c , m , and $f_{11}t_1$ are

N_c	m	$f_{11}t_1$
49,764	1276	.1020
49,842	1278	.1019
51,320	1282	.1016

2. References

Cooper, G. R., and R. W. Nettleton (1976), Efficient spectrum utilization with wideband signals, Final Report TR-EE 77-12, School of Electrical Engineering, Purdue University, W. Lafayette, Indiana.



BIBLIOGRAPHIC DATA SHEET

1. PUBLICATION OR REPORT NO. NTIA Report 79-23		2. Gov't Accession No.	3. Recipient's Accession No.
4. TITLE AND SUBTITLE A COMPATIBILITY ANALYSIS OF SPREAD-SPECTRUM AND FM LAND MOBILE RADIO SYSTEMS		5. Publication Date August 1979	
7. AUTHOR(S) John R. Juroshek		6. Performing Organization Code NTIA/ITS	
8. PERFORMING ORGANIZATION NAME AND ADDRESS National Telecommunications & Information Administration Institute for Telecommunication Sciences 325 Broadway Boulder, CO 80303		9. Project/Task/Work Unit No. 9101115	
11. Sponsoring Organization Name and Address National Telecommunications & Information Administration Institute for Telecommunication Sciences 325 Broadway Boulder, CO 80303		10. Contract/Grant No.	
14. SUPPLEMENTARY NOTES		12. Type of Report and Period Covered	
15. ABSTRACT (A 200-word or less factual summary of most significant information. If document includes a significant bibliography of literature survey, mention it here.) The possibility of overlaying a spread-spectrum system into frequency bands containing conventional FM land-mobile systems is examined. Overlaying here is interpreted as meaning the unrestricted operation of spread-spectrum and FM mobiles throughout the same service area and on the same frequency. The report assumes conventional spread-spectrum and FM systems where a single base serves a large urban area. The small cell narrow coverage concept is not discussed. A theoretical compatibility study is described that concludes that significant interference would result to existing FM systems. This conclusion assumes spread-spectrum transmitter powers comparable to existing FM systems. The report considers land-mobile operating frequencies of 150 and 900 MHz. The study also examines the reverse problem of interference from FM to spread spectrum. Curves are prepared showing separation requirement for various channel multipath conditions. A computer simulation program is also described that (continued)		13.	
16. Key words (Alphabetical order, separated by semicolons) Frequency modulation; interference; land mobile radio; multipath; propagation; spread spectrum.			
17. AVAILABILITY STATEMENT <input checked="" type="checkbox"/> UNLIMITED. <input type="checkbox"/> FOR OFFICIAL DISTRIBUTION.		18. Security Class (This report) Unclassified	20. Number of pages 70
		19. Security Class (This page) Unclassified	21. Price:

15. ABSTRACT (Cont'd.)

simulates the operation of a spread-spectrum system in a multiple FM interferer environment. The conclusions are that an overlaid spread-spectrum system also would receive significant interference.

The report also describes a frequency hopping, spread-spectrum system that is programmed to miss those FM channels in use at a given locality. The advantages obtained with this technique are briefly discussed.