

VIDEOTEK Systems and Services

L.R. Bloom

A.G. Hanson

R.F. Linfield

D.R. Wortendyke



U.S. DEPARTMENT OF COMMERCE
Philip M. Klutznick, Secretary

Henry Geller, Assistant Secretary
for Communications and Information

October 1980

PREFACE

This report describes a number of new non-speech telecommunication services soon to be offered to the American public. Videotex is the generic term for systems that transmit text and graphics to the business or home viewer by means of signals carried over a telephone line, cable, or any of the TV or radio broadcast channels. A television receiver equipped with the necessary decoding and memory circuit provides the home user with access to hundreds of "pages" of selected information for viewing by the customer for one-way non-interactive systems. In the broadcast modes of operation, the customer may select by "book and page" from a large selection of subjects being broadcast at some specific time. Interactive Videotex systems allow the subscriber to interrogate a data center by telephone and to select, from hundreds of thousands of stored pages, that information of particular interest to the user.

The report in its present form contains a brief discussion concerning individual types of services, but primary emphasis is upon the need for a highly critical evaluation of a whole group of technological building blocks which already exist. We already have all the pieces provided for user-oriented national or international computer-based communications and information networks. The terminals are as close to our office or home as are the ubiquitous telephones, and as viewable as the (almost) standard home television receivers. In other words, the technologies are existent. The new systems may be provided in many forms of convenience and over a wide range of costs; the information may be delivered by a few of the many transmission systems now widely in use. The implications of such a computer society have not been effectively evaluated. There are numerous economic and social implications which are beyond the scope of this report. Moreover, the degree to which the public will accept such services is unclear. While a number of firms in this country are examining this market, a great deal of uncertainty still exists as to what types of services might be successfully marketed to the office or to the home.

TABLE OF CONTENTS

	Page
PREFACE	iii
LIST OF FIGURES	vii
LIST OF TABLES	ix
ABSTRACT	1
1. INTRODUCTION	1
1.1. Summary Discussion of Types of Service	2
1.1.1. Broadcast VIDEOTEX	2
1.1.2. Continuously Interactive VIDEOTEX	3
1.1.3. Intermittently Interactive VIDEOTEX	4
1.2. Operation of Broadcast VIDEOTEX Systems	5
1.3. Operation of Interactive VIDEOTEX Systems	10
2. COMMERCIAL SERVICES, PROPOSED AND OPERATIONAL	14
2.1. Background	14
2.2. The United Kingdom	16
2.3. Western Europe	21
2.4. Japan	26
2.5. Canada	32
2.6. The United States	39
2.7. Operational Parameters of Representative Systems	59
2.7.1. Comparison of Various Generic Systems Summarized	70
3. STANDARDS AND STANDARDIZATION	71
3.1. Compatible Standards for Broadcast and Interactive Systems	73
3.2. Display Formats and Character Sets	74
3.3. Standards for the Commercial TV Receiver as a Terminal	81
3.4. International Standards Objectives	82
3.5. Summary of Coding Compatibility and International Standards	84
4. NETWORKING ASPECTS OF INTERACTIVE VIDEOTEX SYSTEMS	85
4.1. System Architecture	86
4.2. Centralized Network Services	90

TABLE OF CONTENTS (Continued)

	Page
4.3. Network/Systems Protocol and Computer Architecture	92
4.3.1. Communications Protocol	93
4.3.2. Computer Architecture	94
5. IMPACT OF VIDEOTEX SERVICES ON THE LOCAL LOOP	95
5.1. Switch Technologies and Selection Criteria	96
5.2. Traffic Considerations and Switch Capacity Limitations	101
5.3. Broadcast and Interactive Systems Concepts	105
5.4. Grade of Service Estimates for Green Thumb Test Bed	109
5.5. Future Concepts	111
5.6. Issues and Problems Remaining	111
6. ECONOMIC CONSIDERATIONS: COSTS TO INDUSTRY AND USERS	113
6.1. Broadcast Services	113
6.2. Interactive Services	118
6.2.1. Prestel Capital Investment Costs	119
6.2.2. Systems Costs for the U.S.	121
7. SUMMARY REMARKS	124
8. ACKNOWLEDGMENTS	129
9. REFERENCES	129
APPENDIX A	131
APPENDIX B	141
APPENDIX C	152
APPENDIX D	158

LIST OF FIGURES

	Page
Figure 1. U.K. Teletext data line insertion into composite video signal.	6
Figure 2. Display blocks of alphanumeric and graphics.	9
Figure 3a. Interactive VIDEOTEX Tree Structure.	12
Figure 3b. VIDEOTEX Information Access Routes.	12
Figure 4. Sample information "pages" (U.K. broadcast service).	13
Figure 5. Prestel interactive system architecture.	19
Figure 6. Japanese CAPTAIN system architecture.	31
Figure 7. Canadian Telidon circuit designs with and without high resolution graphics.	35
Figure 8. Comparison of Telidon bit-map and mosaic memory display.	36
Figure 9a. Comparison of alpha-mosaic and alpha-geometric displays.	37
Figure 9b. Example of descriptive power of Telidon alpha-geometric mode.	37
Figure 10. Proposed system architecture for Canadian Project Ida.	42
Figure 11. PLATO systems usage.	45
Figure 12. Proposed PROFS schedule for interfaces with external systems.	48
Figure 13. Proposed Insac Corporate Viewdata system.	51
Figure 14. A proposed new mode in the Bell System network.	58
Figure 15. 1A Voice Storage System architecture.	58
Figure 16. Typical Data Network Distribution Architectures.	87
Figure 17. VIDEOTEX Packet-Switched Network.	89
Figure 18. Breakdown of switch technologies.	97

LIST OF FIGURES (Continued)

	Page
Figure 19. Control technologies and approximate year each has been introduced.	98
Figure 20. Relating network properties to switch technologies.	100
Figure 21. Approximate operating ranges for line and trunk traffic.	103
Figure 22. Relating basic switch parameters.	104
Figure 23a. Example of normal load carried by end office 20,000 lines.	108
Figure 23b. Load carried by end office assuming 10% of calls are trunked to data bank.	108
Figure 24. Local switching for multiple subscribers accessing a single data bank.	112
Figure 25. Schematic: Cost breakdown of an interactive VIDEOTEX network.	120

LIST OF TABLES

	Page
Table 1. U.K. Teletext broadcast VIDEOTEX character codes	8
Table 2. Typical HI-OVIS services	28
Table 3. Possible uses of Canadian Project Ida	40
Table 4. Participants in Project Ida	41
Table 5. Corporate Viewdata: Tentative User Charges	51
Table 6. Operational parameters of representative VIDEOTEX systems	60
Table 7a. System's operator aspects of interactive (duplex) VIDEOTEX systems	62
Table 7b. System's operator aspects of broadcast (simplex) VIDEOTEX systems	63
Table 8. Modified ISO 2022 alphanumeric character set used in U.K. Ceefax/Oracle broadcast systems	75
Table 9. "C1" Character Set for Color and Graphic Display	76
Table 10. Character set for mathematical and other special symbols	78
Table 11. Modified character set for Northern European and German languages	79
Table 12. Modified character set for special characters	80
Table 13. Features available for a modern PBX	91
Table 14. Pertinent characteristics for some commercial systems	106
Table 15. Blocking estimates for Green Thumb test	110
Table 16. Added cost/price for data/caption systems	115
Table 17. Ancillary information systems	116
Table 18. Interactive VIDEOTEX systems cost for a regional data center	123

VIDEOTEX SYSTEMS AND SERVICES

L. R. Bloom, A. G. Hanson, R. F. Linfield, and D. R. Wortendyke*

A new, consumer-oriented family of innovative information distribution services, generically termed VIDEOTEX, is being offered to the European and Japanese public. Several field trials are underway in the U.S. Normally using a modified home TV receiver as the display terminal, services provide user access to broad varieties of computerized data banks. Distribution to the user is typically via broadcast TV (one-way services) or the switched telephone network (two-way, interactive services). Also, there exist hybrid services in which the requested service may be transmitted over a different medium than the received information. This report discusses representative services and distribution system architectures, potential impact on the telephone network, the need for and status of standards, and economic considerations for user and suppliers.

Key words: Broadcast television; coding formats; communication; computer networks; data bank; data communication; data networks; display; Green Thumb; information distribution; information retrieval; information systems; network architecture; non-speech telecommunications; standards; systems architecture; telecommunications; telephone network; Teletext; television receiver; terminal; VIDEOTEX; Viewdata

1. INTRODUCTION

A relatively new type of non-speech telecommunication services for public use has been available --albeit on an extremely limited scale so far-- in a number of systems overseas (since 1976 in Canada), and is now being offered in the United States by GTE through adoption of the U.K. interactive VIDEOTEX, called Prestel, and by AT&T/Knight-Ritter through a similar adaptation of Canadian Telidon. Data access systems typically make use of existing TV broadcast channels or of the switched telephone network to provide communication links between centrally or strategically located computers or data banks and the home TV receiver, which serves as the terminal display device. Most recently two-way information services have also become available via coaxial cable (CATV). None of the presently offered services makes use of audio to augment the video presentations; hence the term "non-speech telecommunications."

*The authors are with the Institute for Telecommunication Sciences, National Telecommunications and Information Administration, U.S. Department of Commerce, Boulder, CO 80303.

During the evolution of the first several of these services, a number of generic descriptors were employed and quoted in the literature. Most of these names subsequently have become trademarks or their equivalent. The CCITT tentatively has chosen "VIDEOTEK" as the generic term to describe all such services, and this report will follow that practice. In accordance with CCITT usage, simplex (one-way) transmission systems that typically employ TV broadcast channels will be referred to as "broadcast VIDEOTEK." Two-way (duplex) systems that typically utilize the switched telephone network, cable TV, or private networks will be referred to as "interactive VIDEOTEK."

To emphasize fundamental distinctions between two modes of telephone network use, the duplex systems are further categorized into two subsets. Those systems (including most currently operational or in advance planning stages) that require user telephone connection during the entire data bank interrogation/display time period are designated "continuously interactive VIDEOTEK." Those systems that require a shorter-duration telephone network interconnect time, utilizing a "dump and disconnect" mode of operation, are designated "intermittently interactive VIDEOTEK." United States Department of Agriculture experimental Project Green Thumb is an example of the latter type system.

The interactive category also includes several specialized systems which offer services considerably more sophisticated than those of a majority of the systems to be discussed. These duplex systems vary significantly from the "typical" VIDEOTEK technology in one or more of the following parameters:

- . transmission facilities (e.g., coaxial cable, optical fiber),
- . method of display (e.g., specialized coding formats, specialized terminals),
- . access protocol (including user terminal-to-terminal interaction), and
- . data bank (e.g., high capacity, specialized, user-oriented information).

The education-oriented U.S. Plato system and the wired-city Japanese HI-OVIS are prime (and vastly differing) examples of these highly innovative services. In order to avoid proliferation of another hierarchical category, these systems will be discussed as "continuously interactive VIDEOTEK."

1.1. Summary Discussion of Types of Services

1.1.1. Broadcast VIDEOTEK

Broadcast VIDEOTEK, first developed in England where it is known as Teletext, is a generic term for a family of one-way-only circuit (simplex) services that connect a modified home TV receiver with a data center and its computer to provide

a large file of information to the user. The information, whether alphanumeric or graphic, is transmitted (broadcast or cable) via commercial or public TV channels. The information is carried on the vertical blanking (retrace) intervals of the video subcarrier, and is recovered and recorded using devices called decoder boxes for display on a modified TV receiver. Pages of information covering a variety of subjects are transmitted to the receiver, (as many as four to six pages per second) for later capture and retrieval by the viewer. Since each TV channel can carry a selected body of information (pages), the library of information can be varied to include a large number of topics; e.g., weather, stock market reports, theatre listings, restaurants, etc. Capacity is set by the number of pages transmitted per second and the length of time a user is willing to wait for the desired pages to come up. Capture is performed by punching in the page numbers of those desired two to four pages on a hand held keypad. These pages are automatically captured and stored for as long as desired by the user. Retrieval for viewing is accomplished by storage of data in the decoder memory. Storage may be for one or several pages, dependent upon the size of memory.

Presently, the British systems can provide up to 800 pages per channel (up to 100 words per video frame or "page"). Information on broadcast systems may be displayed in color or black and white, and the data may overlay or replace the TV program being shown. The variety and frequency of updating is a matter of economics--not technical constraints. Broadcast VIDEOTEX systems in England (Teletext) go under the names "Oracle" or "Ceefax," and in France systems are trademarked under "Antiope." Germany, Sweden, Holland, Finland, and Japan have by now all developed their own systems. The United Kingdom and France appear to have a head start; about 10,000 terminals are now in service, and the number is expected to go up to 100,000 by 1980. Station KSL-TV (Salt Lake City) is planning the first U.S. trial service of a British version of broadcast VIDEOTEX called Ceefax.

1.1.2. Continuously Interactive VIDEOTEX

Two-way data systems are known generically as interactive VIDEOTEX. A whole family of systems, now coming into existence, are fully interactive--and most often use the telephone and the telephone switched network as the umbilical for supplying data and other useful information from a data memory bank and a central computer processor. These duplex systems allow specific user requests for information from computer data files, requiring only a subscriber account identification

and, in the case of restricted information, a special access code. The descriptor "continuously interactive" is used to convey the fact that a user/data bank circuit connection is maintained through the switched telephone network for the entire period of data request and retrieval. It should be noted that a number of "other" interconnecting networks have been proposed or introduced experimentally to provide either public or dedicated interactive information services.

Typical of the interactive kinds of services is the Prestel system of the British Post Office. Prestel offers almost all of the display features of broadcast VIDEOTEX, e.g., format and color contrast, but it has one important difference. Prestel uses the telephone and its switched network as the communication channel to access a data base that is almost unlimited--as large and as varied as economics and user needs might dictate. Rather than watching successive pages flash onto a screen and waiting to capture a few pages, Prestel users can query a cooperative information source to whatever detail is requested. The power of the interactive system is that the common home TV receiver becomes a display terminal which receives information from the existing telephone--and with little more complication than the modification of the TV receiver to include a character generator set and a decoder box to interconnect the TV receiver and the telephone. The decoder receives traffic from the data center and translates the information into a suitable ASCII (American Standard Code for Information Interchange) code for display on the TV terminal. The home or office user may seek successively greater detail of information, request other kinds of information, or elect to do problem solving where such capability is built into the systems.

Additional candidate systems entries into the field include the U.S. GTE/Viewdata and Dow Jones/Apple, CompuServe/Micronet, Canada's Telidon, and the Japanese HI-OVIS and CAPTAIN.

Most of the systems described above are generally low data rate or narrowband, using the telephone or carrier-type systems. Exceptions to the narrowband transmission are HI-OVIS and Project Ida which use broadband optical fiber cable to supply video as part of the interactive communications link.

1.1.3. Intermittently Interactive VIDEOTEX

One U.S. system which was developed cooperatively between the National Weather Service, the Department of Agriculture, and the University of Kentucky is called

Green Thumb. The system is now undergoing field trials at two separated points in rural Kentucky. Each of the test areas has approximately 100 homes connected into the Green Thumb system. This is a telephone-interconnect system which provides highly specific and selective weather, farm and market prices, and a variety of other useful information at low cost to farmers.

As with other interactive VIDEOTEX systems, users plug in the "Green Thumb box" between the telephone and TV. The system relies on a "dump and disconnect" mode of operation to receive a burst of information, store it in the memory of the box, and provide subsequent retrieval and display at command of the user. (This "intermittently interactive" mode minimizes telephone connect time and subsequent congestion of the switched network.) No modification in the TV receiver is necessary. Data input modulates an available rf channel carrier for input directly into the antenna terminals. Operation is relatively uncomplicated. Before calling the data center, the subscriber makes selections of a number of pages from a written memo or from prior screen information. The information is fed into the decoder box memory and is transmitted to the data center. Data is then loaded into the decoder box from the computer, after which the computer disconnects. The subscriber may then successively review the pages of information selected.

1.2 Operation of Broadcast VIDEOTEX Systems

The principal operation and technical features of broadcast VIDEOTEX systems are as follows:

This is an information broadcasting service in which frames or pages of text or graphical material and symbols are transmitted in a coded form on otherwise unused positions of the television raster scan, usually during the vertical blanking interval. The vertical blanking interval (VBI) of a television composite video signal contains, in addition to the picture information and audio, other necessary signaling information to insure proper operation. These include line synchronization or time-run-in, framing information, testing, and also technical signal information useful to studio and transmission operation (See Figure 1.) These specialized housekeeping and protocol signals necessary for TV studio operation are transmitted on a series of raster scan lines not normally viewable on the home TV screen. In the British Teletext system, for example, some 25 or more lines are transmitted during this interval and some of these lines may be converted for use as data lines to carry VIDEOTEX information. Initially two pairs of lines (four lines in all) have been chosen to provide the useful information which may be captured and displayed on the TV screen.

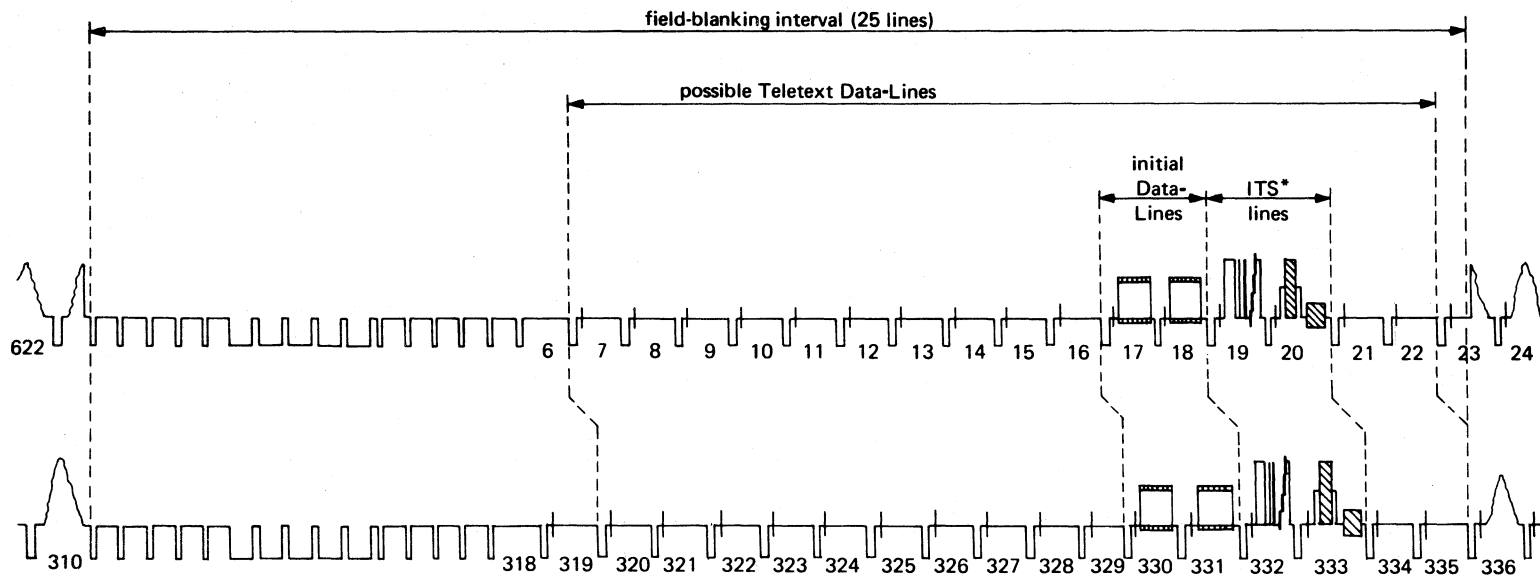

*Insertion Test Signal

Figure 1. U.K. Teletext data line insertion into composite video signal.
 (Source: Broadcast Teletext Specifications, 1976).

Decoded information in the form of "pages" are stripped from the composite video signal containing the data lines, decoded, stored, and displayed, on command, either in place of or overlaying the normal television picture being broadcast on that channel. Subtitles or newsbulletins may also be inserted during the normal TV broadcast at command of the user where such pages are provided. As with interactive VIDEOTEX systems, a keypad with suitable command and control functions and page memory store is used to operate the broadcast VIDEOTEX System.

With some exceptions, the decoded bit stream extracted from the television subcarrier is in the form of a series of 7-bit digital words (bytes). This permits the modified circuitry in the TV receiver to display, on the picture tube screen, alphanumeric in the form of textual display as well as a limited form of graphics or pictorial display, by combining some of the characters in the form of mosaic representations. As will be noted later, more detailed graphics can become available with some additional complications at the receiver, also with some additional requirements in the coding format. With color TV receivers, color may be added either to the background or to the characters themselves to emphasize or enhance the displays.

As will be noted later, a 7-bit character code can in itself permit only 128 decisions or commands. Since about 70 of these code words are needed just to describe upper and lower case alphabet, numerics, and some standard punctuation and symbols, only a relatively few code words are left for commands such as spaces, end of line, clear page, color, etc. Special shift commands have been offered by some of the systems developers (e.g., Telidon and CAPTAIN) to increase the flexibility and detail which can be represented.

A typical character code representation is shown in Table 1. The actual details of mosaics or characters are represented in Figure 2.

In the European systems, such as Ceefax and Antiope, data transmission signaling is at the rate of 6.9375 Mb/s during each data line. This signaling rate is compatible with 625 line television receivers with at least 5 MHz video bandwidth. It is to be noted that U.S. and Canadian systems which use the 525 line TV broadcast standards, but with equivalent bandwidths of 5 MHz or greater, must compromise by using a smaller number of display characters per row, usually 40, 36, or only 32, and a smaller number of total lines, 20 instead of 24. This is to be compared with the European systems which all can display, with good resolution, pages of 24 rows of 40 characters each.

b7 b6 b5					000	001	010	011	100	101	110	111				
Bits					0	1	2	2a	3	3a	4	5	6	6a	7	7a
b4	b3	b2	b1	Col Row												
0	0	0	0	0	NUL ^①	DLE ^①			0		@	P	-		p	
0	0	0	1	1	Alpha ⁿ Red	Graphics Red	!		1		A	Q	a		q	
0	0	1	0	2	Alpha ⁿ Green	Graphics Green	"		2		B	R	b		r	
0	0	1	1	3	Alpha ⁿ Yellow	Graphics Yellow	£		3		C	S	c		s	
0	1	0	0	4	Alpha ⁿ Blue	Graphics Blue	\$		4		D	T	d		t	
0	1	0	1	5	Alpha ⁿ Magenta	Graphics Magenta	%		5		E	U	e		u	
0	1	1	0	6	Alpha ⁿ Cyan	Graphics Cyan	&		6		F	V	f		v	
0	1	1	1	7	Alpha ⁿ White	Graphics White	'		7		G	W	g		w	
1	0	0	0	8	Flash	Conceal Display	(8		H	X	h		x	
1	0	0	1	9	Steady ^②	Contiguous ^② Graphics)		9		I	Y	i		y	
1	0	1	0	10	End Box ^②	Separated ^② Graphics	*		:		J	Z	j		z	
1	0	1	1	11	Start Box	ESC ^①	+		;		K	←	k		1 ₄	
1	1	0	0	12	Normal Height ^②	Black ^② Background	,		<		L	1 ₂	l		ll	
1	1	0	1	13	Double Height	New Background	-		=		M	→	m		3 ₄	
1	1	1	0	14	SO ^①	Hold Graphics	.		>		N	↑	n		÷	
1	1	1	1	15	SI ^①	Release ^② Graphics	/		?		O	#	o			

① These control characters are reserved for compatibility with other data codes

Codes may be referred to by their column and row e.g. 2/5 refers to %

Character rectangle

② These control characters are presumed before each row begins

Black represents display colour

White represents background

Table 1. U.K. Teletext broadcast VIDEOTEX character codes. (Source: Broadcast Teletext Specifications, 1976).

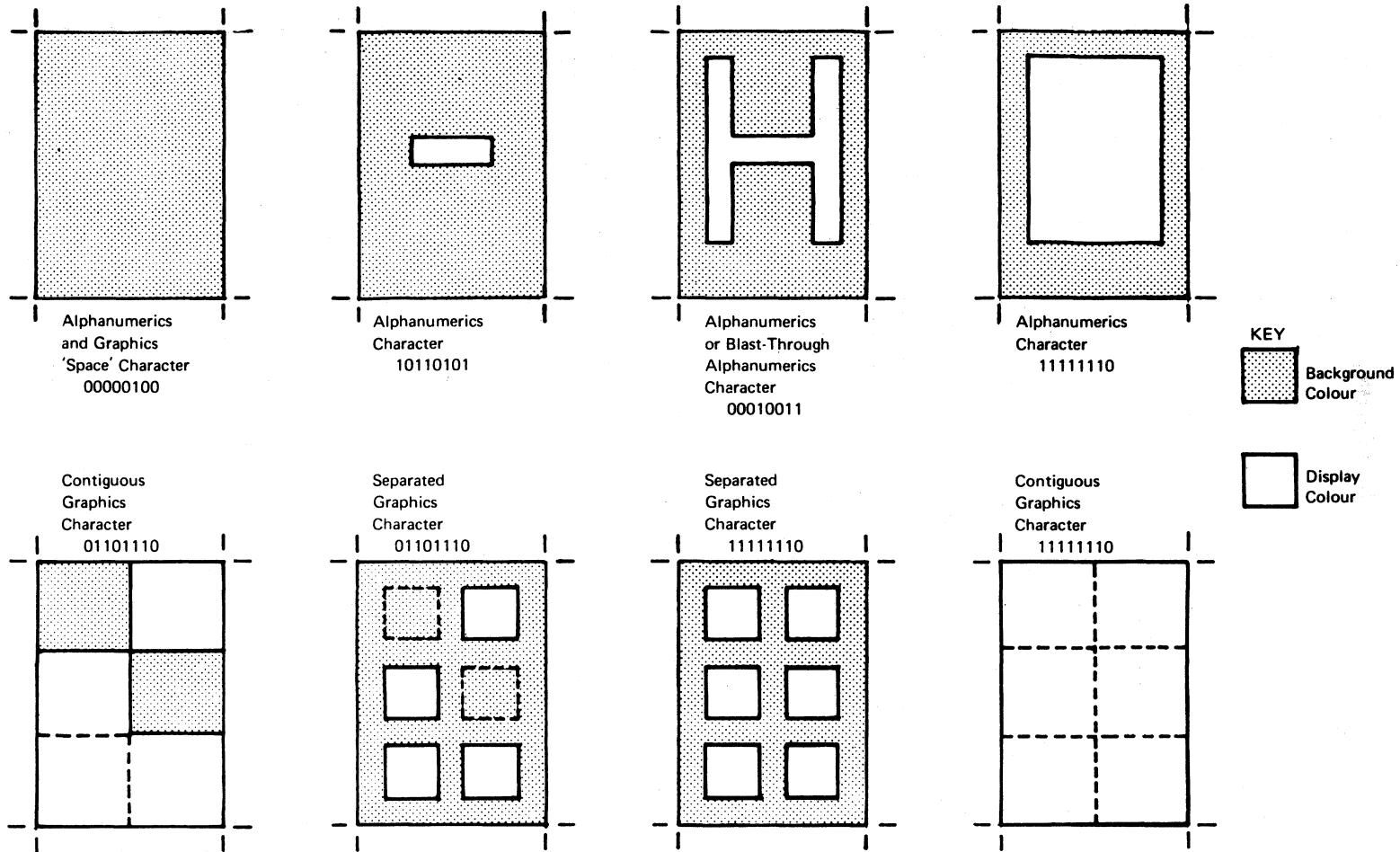

Note: Character Bytes are listed as transmitted from b_1 to b_8

Figure 2. Display blocks of alphanumerics and graphics.
(Source: Broadcast Teletext Specifications, 1976).

Operationally, some four pages are transmitted per second and at the user's discretion, as many as four pages can be captured, stored, and viewed sequentially at the leisure of the subscriber. The British systems make provisions for a total of 800 pages per TV channel, about 100 pages per "magazine," or selection as chosen by the viewer.

Control features inbedded in the transmitted data stream and character code provide for:

- . synchronization and display of up to 960 characters on a TV screen (less then 800 for U.S. systems),
- . character color display (up to 7 colors),
- . individual flashing on and off of selected characters.

Control features available at the request of the user permit him to:

- . select specific pages from "magazine" or "book" being broadcast,
- . overlay data on broadcast TV program or to replace TV picture,
- . reveal or conceal mode of viewing of character (at option of user) in a flashing or continuous mode.

To point out one strongly distinguishing difference between interactive and broadcast systems, the viewer of broadcast VIDEOTEX has no real-time control or decision-making capability in the selection of the "magazines" to be viewed. He can only select from what is being broadcast. In the interactive system (with the exception of some restricted material), the subscriber can demand and receive any of the "books" and "pages" stored in the library.

1.3. Operation of Interactive VIDEOTEX Systems

The keypad is the command and control center for the user of interactive systems. Pressing a service request key changes the TV receiver function from conventional broadcast reception to VIDEOTEX reception and display. This also instructs the user's decoder/microprocessor to initiate a telephone connection to the computer and to accept the requested information from the computer data bank. The decoder also automatically transmits the user's unique identification number to the computer center for purposes of customer billing.

Upon completion of these connect, handshake, and identification procedures, the keypad is now available for use in data search modes. Proper keying allows interrogation of the computer data banks and permits the display of "pages" (video frames) of alphanumeric or graphic information according to the requested topic and required detail within that listing. Literally hundreds of thousands and even millions of

pages of information can be stored and made available to the user at his request. This would be analogous to a researcher studying a particular subject in a library where the searcher may first dig through the subject files or title files in the card catalog for suitable entries pertaining to his interest. He records the publication reference codes (addresses) and then proceeds to the book or periodical stacks for selection of the material he wishes to read and review. According to the proponents, vast libraries of data may similarly be stored in the data base ("stacks") of VIDEOTEX systems to be made available via a few intelligent commands by the operator. Indeed, the claim is that, in a fully implemented system, a maximum of 10 commands can bring any stored entry into display.

An example of a typical method of interrogation is that of the British Prestel system, which uses a top-down tree structure (See Figure 3a). Sample pages of the output of Prestel are given in Figure 4. According to the British Post Office, which operates the Prestel system, more than 200 topical areas have already been identified and filed into the VIDEOTEX data base. As indicated above, a mature, fully loaded, data center should allow a reader to access hundreds of millions of pages--the equivalent of a major library.

The structuring of the information files have been organized such that a particular data base may allow for direct selection down through the branches of the tree or to permit bypassing of intermediate data and moving in a few sequences directly to the information being sought. As shown in Figure 3b, access to particular blocks of information may also allow switching from one branch of the tree to another or in some cases between trees.

Regarding the questions of who pays for the services offered, VIDEOTEX is offered in the United Kingdom on a cost per page charge plus the time/distance charge for use of the telephone. These charges, of course, are in addition to the costs for leasing or purchase of the TV receiver/decoder/telephone interface equipment that makes up a complete VIDEOTEX user terminal system. More will be said later about the economics and tariffs of VIDEOTEX systems, and also comparisons between broadcast services and interactive systems such as Green-Thumb, PLATO, and Prestel.

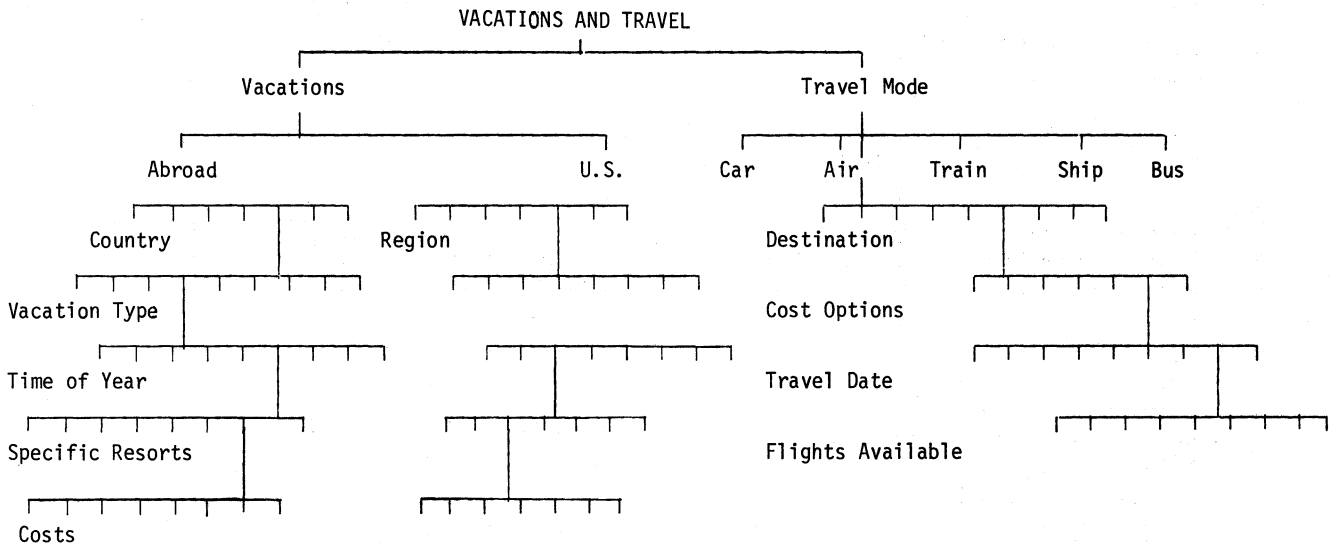

Figure 3a. Interactive VIDEOTEX Tree Structure.

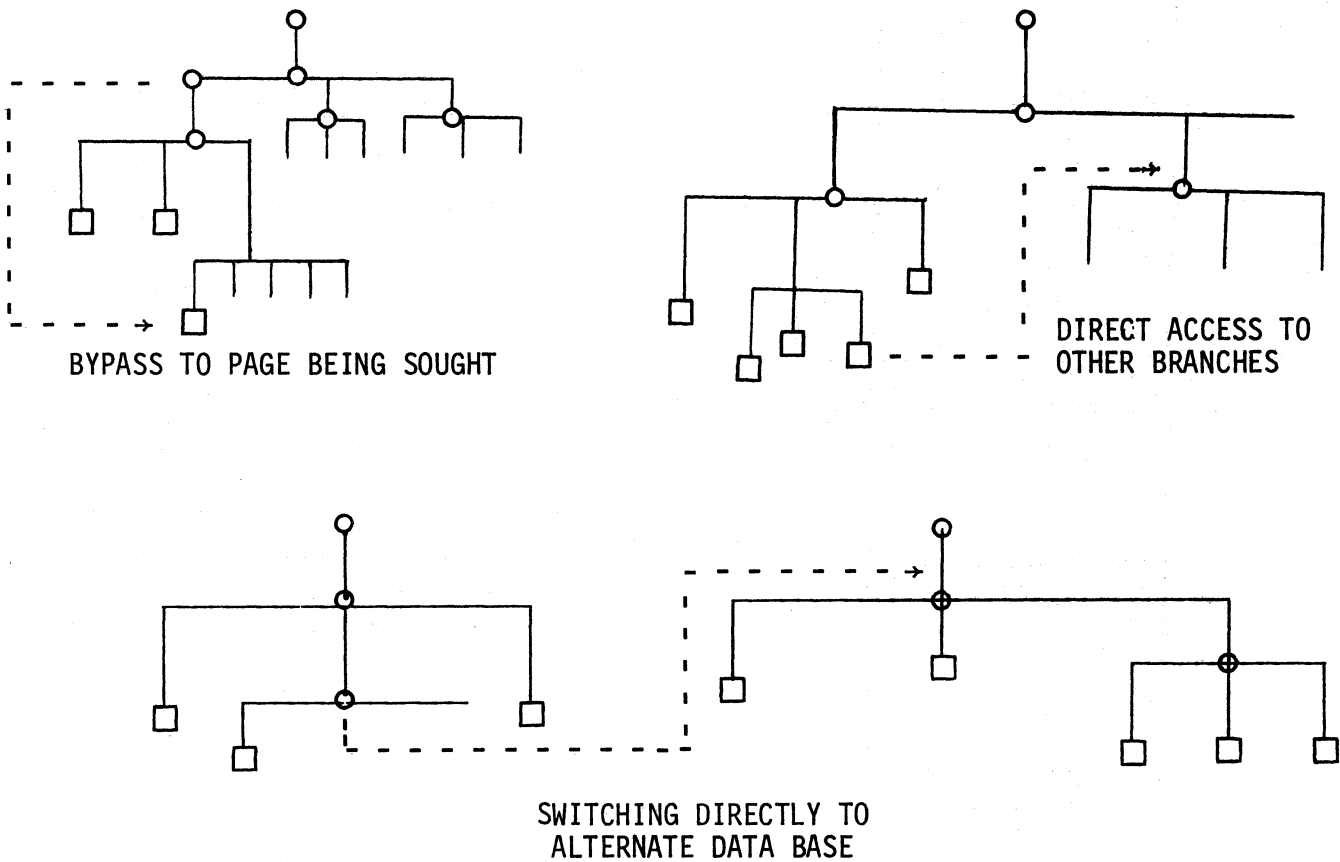

Figure 3b. VIDEOTEX Information Access Routes.



CEEFAX

instant dial-a-page news from the

BBC

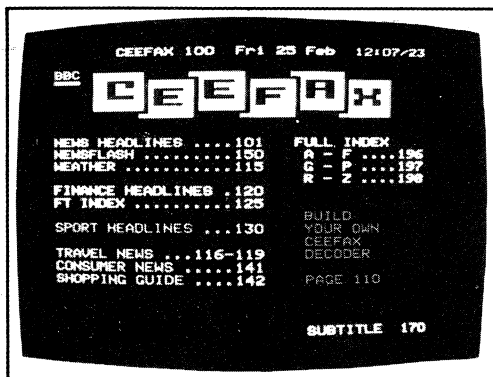

Figure 4. Sample information "pages" (U.K. broadcast service).

2. COMMERCIAL SERVICES, PROPOSED AND OPERATIONAL

2.1. Background

As suggested in the body of this report, there are by now a large number of VIDEOTEX systems in the process of installation or under investigation by various commercial or government organizations throughout the world. The best known of the recently installed interactive systems is the British Prestel Service, a two-way interactive system between the subscriber and the data information source. Data access is through the switched network and conventional telephone set. Connection is via simple dial-up to the central data bank. The British Post Office (BPO) installed their first Prestel System for commercial operation in England early in 1979. The BPO intends to offer this form of new data dissemination as a commercial, profit making enterprise, not only in England, but also within the United States and other foreign countries.

A user-oriented survey on Prestel was conducted among a large number of firms and private organizations within the United States (Woolfe and Gaffner, 1978). A portion of the survey information is available only to clients of the study. However, some of the key concerns and issues which were brought up as topics within the survey should receive some note, and will be discussed in detail elsewhere in this report.

In an interactive system such as Prestel, there are a large number of directly involved participants. There are, of course, first the information providers, or the IP's. The information providers might include a large variety of businesses, publishing houses, financial organizations, the computer and time-sharing industry, banking, direct sales organizations (as in advertising over TV), the travel industry, and many, many others. Before the information providers can become really responsive to Prestel or other interactive systems, they would like to make sure that the visual format available at the home TV receiver, with its limited alphanumeric and limited graphic presentations, would provide an effective medium for their intended sales purposes.

The choices among interactive versus broadcast systems in the U.S. are being considered by a number of entrepreneurs. It is to be noted that the French Antiope System, as well as the pioneer Ceefax and Oracle systems presently in operation in Great Britain, are all one-way types of data transmission and data handling systems. Such broadcast VIDEOTEX systems are somewhat limited. The information available to

the customer is under the user's control only to the extent that several pages per second are displayed on the customer's TV screen for review, permitting a small number of such pages to be captured for casual viewing a page at a time. The broadcast system of the type described above may be arbitrarily limited to a fairly small number of total pages, of the order of 100 to 200 maximum pages, since at four pages per second it takes 25 seconds for a particular volume or catalog of information of 100 pages to be viewed, reviewed, and pages selected and captured. The maximum number of pages which could be reviewed at any one time would of course be dependent upon the size of the memory available within the customer's key pad and decoder boxes for later reuse. At present, a maximum of two to four pages seems to be the limit before the cost of the storage elements become too great for consideration by the customer. Rapid technical progress is being made in memory components including increased word capacity to 8000 bytes and 32,000 bytes. Memory chips for 32K bytes appear to require no more space on the chips today at about the same cost as 4K byte chips of just a few years ago. The incorporation into the receiver of much greater memory capacity at small additional costs may offer technical improvements leading to more flexibility in data processing and data management as well as higher resolution graphics.

The broadcast system is a rather straightforward type of system. It does require modification (as do almost all VIDEOTEX systems) of the customer's television receiver. It also requires a decoder box or key pad. But it cannot readily expect of the customer additional cross-payments to the telephone company or data system operator on the basis of use and time of operation. Fixed or monthly rental charges for installed equipment might be made by the information providing organizations. The equipment might be purchased from non-affiliated suppliers, particularly if the service is advertiser supported. The customer is limited to the information that becomes available, such as terse newspaper headline information, weather, travel information, financial information, gardening, education, and so forth.

Interactive VIDEOTEX

Establishing of interactive VIDEOTEX connections between customer and data bank involves an interactive or duplex mode of transmission, special modifications of the viewing terminal, procedures for subscriber identification for setting up billing, and procedural arrangements for communication including coding formats, character sets, housekeeping, directory listings, and auxiliary types of interactions.

Although it is hardly clear today as to what form standards will take in the development of system architectures for either interactive systems or broadcast VIDEOTEX systems, it may be a desirable situation to provide compatibility for access by any of several different kinds of systems. Compatibility will require common or easily translatable coding formats, attention to the limitations of several kinds of display systems, common data rates or buffering storage, and the ability to take advantage of a given key and decoder system to access a number of different kinds of services. It is also conceivable that inputs by information providers will be offered not only through central data sources, but also through direct interaction from specialized user terminals. Interoperability with a wide variety of user terminals increases the flexibility of such systems.

Overseas there is already anticipation of some type of a central processing or conversion center whereby information could be entered into the data systems from a variety of formats and user terminals, reprocessed, and introduced into commonly shared computer and data systems in such fashion that compatibility is maintained between the many subscribers and the communication data storage system.

Standards may also have to be developed for the layout of messages. Basic interoperability is concerned with the choice of graphic symbols, the methods for coding of graphics and control functions, and the protocols employed in transmission media interconnection. Interoperability will provide for translation of data into proper formats from one terminal to another such that it becomes directly usable in another terminal. Probably the most flexible type of system is that which provides common codes for a variety of terminals and services. Symbols, graphics, and alphanumerics are formatted with some type of common coding system such that decoders do not have to be modified for each of the types of presentations.

Although overall compatibility may not be achieved, basic interoperability demands that there be agreement over which of the symbols will be accepted and which may be readily eliminated within a limited code. Questions have been underway since early 1978 in CCITT Study Group VIII and its predecessor groups with respect to symbol and coding formats relating to broadcast and interactive systems. This has resulted in the present advocacy for provisions of a catalog of graphic symbols and alphanumeric symbols to provide a symbol repertoire which is, at the very least, common and permits some selection by the user of a particular display format. Coding systems or coding schemes for transmitting the information may then be chosen on the basis of terminal capabilities and terminal requirements. These questions of

standards for character sets and other areas of compatibility are discussed in more depth in the section of this report entitled Standards and Standardization.

2.2. The United Kingdom

The British have pioneered in both the development and fielding of VIDEOTEX systems and services to (primarily) home subscribers on a mass basis. The earliest systems (still in service and growing) were simplex TV broadcast, generically designated Teletext, including the Ceefax and Oracle services. The second generation system, Prestel, is duplex interactive and was labeled a "Viewdata type system" (prior to the CCITT-recommended terminology) in order to distinguish it from the "Teletext" broadcast services.

Ceefax and Oracle

At the beginning of the 1970's, both the British Broadcasting Company (BBC) and the Independent Broadcasting Authority (IBA) developed and introduced methods for insertion of encoded data into the vertical blanking interval of the composite broadcast television signal (Woolfe and Gaffner, 1978). The BBC system was named Ceefax (for "Seeing Facts"), and the IBA system, Oracle (for "Optical Reception of Announcements by Coded Line Electronics").

In Ceefax, the information is conveyed in digital format by insertion of the data into video raster lines 17 and 18, and 330 and 331 in the interlace field of the 625 line British system. In such a system, transmission of a "page" (a video frame) is accomplished in 0.24 seconds, and up to 960 characters per frame are displayed on the viewing screen. Character generating circuits have been introduced at the TV receiver to generate alphanumeric or graphic displays, in multi-color or black and white, on this modified home receiver. The IBA Oracle system is technically almost identical to Ceefax; differences include minor variations in modulation techniques. Both services can be displayed on the same modified home TV receivers, as can the recently introduced Prestel interactive service. Although as many as 20,000,000 sets throughout Britain have the potential to receive Ceefax or Oracle services, modification of TV receivers has as yet not kept pace with this potential availability. As of mid-1980, only about 1500 sets have been modified or specially built to accept broadcast VIDEOTEX services.

Prestel Public Services

The Prestel System is among the more mature interactive VIDEOTEX systems being offered to home and business users throughout the world. Considerable financial

and public commitment has been given to this service since its inception in 1976. A number of European and U.S. proposed systems have been modeled after Prestel. Therefore more discussion will be given in this report to the details of the PRESTEL system, as well as TELIDON, and CAPTAIN as representative of pictorial advanced VIDEOTEX Systems.

The Prestel interactive VIDEOTEX service was initially developed by the British Post Office (BPO) with the intent of promoting a higher use of the capacity of the domestic telephone network. Although experimental hookups for Prestel were underway in 1976, actual market trials did not start until 1978. Limited-area public service was instituted in March 1979. Prestel has clearly evolved into a "partnership" among three industry services including the BPO (telephone company), the information-provider industries (IP's), and the television industry. The invention of PRESTEL and most of the initial R&D, as well as the funding of field trials, has come from the BPO. This British system concept is to provide regional data centers, whose computers are interconnected to one another and to the local switched networks which provide subscriber terminal access via the telephone as shown in Figure 5.

Field trials began in 1973. The main computer and storage facility was a GEC 4082 with 100 ports for 1500 initial users. The network has since grown to the point that in June 1980 there are four stand-alone retrieval computers in the London area with six other computers installed in pairs in Birmingham, Edinburgh and Manchester. The ten computers can output to approximately 1000 user ports, expandable as required to 2000 when the number of subscribers goes up significantly.

The GEC 4082 computer with 512 megabyte capacity will interconnect to the 10 and later to 20 retrieval computers to handle the data files. The initial data base consists of approximately 164,000 information pages (June, 1980) with planned update capacity of 260,000 pages. A page consists of a maximum of 960 data characters (5x7 bits each, suggesting approximately 35,000 bits per page). Supplied by 138 IP's and 116 Sub-IP's, the Prestel-adapted TV receivers should be able to receive also the one-way British Ceefax and Oracle services broadcast by the BBC and IBA. The BPO had estimated an audience of 50,000 subscribers by the end of 1979. Numbers of subscribers to May 1980 was far short of this goal, however, for a variety of reasons. Set manufacturers in 1979 and as recently as the beginning of 1980 were unable to deliver modified (or new) television receivers with Prestel capabilities due to some production start-up problems. Thus, only about 3600 sets were installed

Information categories itemized by the BPO as representative of the Prestel data base offered to the home subscriber:

- | | | |
|---------------------------|---------------------------|-------------------|
| auto routes | executive jobs | redundancy pay |
| banking | farm produce prices | seafreight |
| buying a house | good buys | sport centres |
| camping | hobbies | stock exchange |
| commercial contractors | international news | technical indexes |
| common market regulations | legal facts | trade directories |
| development land tax | long range weather | tyre suppliers |
| dish washers | museums | walks |
| dress making | natural history | |
| | property for sale or rent | |

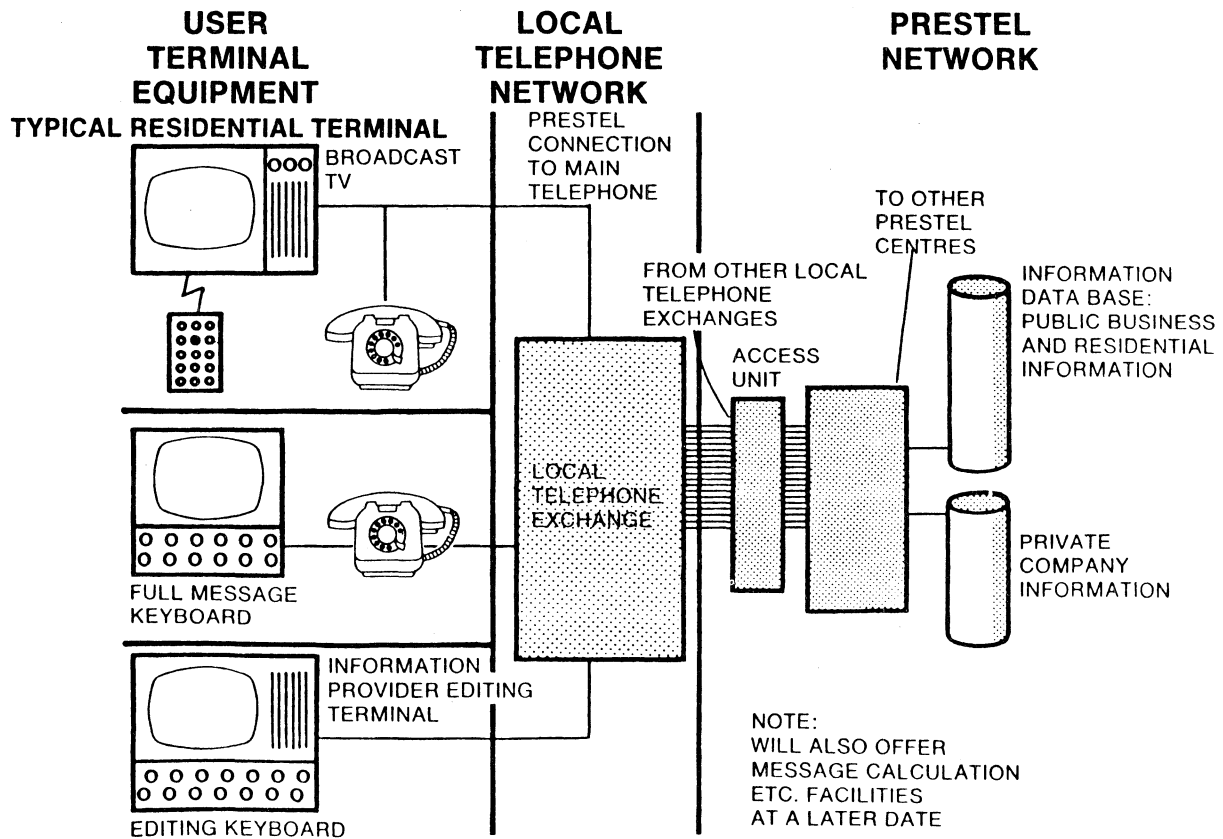

Figure 5. Prestel interactive system architecture.

as of May 1980. Numbers of requests, however, far exceed that number, but still were short of the expected 50,000 by 1980. The British at the CCITT Colloquium in Montreal, June 1980, were quite confident of a large movement forward in the demand for these new services.

Although the BPO is a state monopoly, it has stated that Prestel will be run as a commercial venture--expected to make a profit even without the credit for additional telephone usage revenues (although such revenues almost certainly will increase; the British telephone tariff system includes a per-unit-time charge for all telephone calls, not just "long distance" ones). Some investment costs will be offset by selling the British-developed technology to other countries--including the U.S. General Telephone and Electronics has signed a major contract allowing GTE to offer a Prestel-like system as a public service offering in the U.S. and Canada through an exclusive license with Insac. Similar BPO deals with countries ranging from Switzerland to Hong Kong have reportedly brought in well over \$2 million by mid-1979. Approximately \$35 million was invested in the initial start up of the Prestel service, including R&D (Byrne, 1979). The 1979 BPO budget for Prestel was set at \$60 million, of which \$40-50 million was spent by summer 1979. Based on statements released by BPO officials, the total expenditure will approach \$200 million by 1984. The Post Office Engineering Union's estimate for the same period is vastly higher: in excess of \$320 million (ibid).

In spite of continuing and relatively heavy investment, the BPO is "...spending less than our original estimates for advertising (the Prestel services) because demand far outstrips the availability of the (Prestel-modified TV) sets. So it would be foolish to spend a lot on promoting the service..." (ibid). "There's a demand--on a very big scale," says a spokesman for the National Television Rental Association. "But the sets aren't yet available."

The BPO (as of June 1980) have made the Prestel service available to business users as computer capability has been expanded. Both General Electric Co. Ltd. (GEC) and the Netherlands-based Phillips Data Systems have geared up to capture a share of the private office potential. The GEC basic business system begins at a cost of \$90,000, and the maximum capacity unit (25,000 information pages) costs \$200,000. The Phillips system is priced at approximately \$180,000 for a basic unit. Thorne Electrical Industries Ltd. was also expected to launch a competitive system within the U.K. by the end of 1979.

2.3. Western Germany

Three VIDEOTEX services have been demonstrated in West Germany, the first in September 1977. Two are broadcast systems, one sponsored jointly by the two main TV networks (the ARD and the ZDF), the other by the Federal Association of German Newspaper Publishers (Bundesverband Deutscher Zeitungverleger).

The interactive system, called Bildschirmtext, is actually the British Prestel with a different name. The West German PTT (the Bundespost) has purchased the use of the Prestel software and expertise from the British Post Office, along with a GEC 4080 computer, in order to conduct field trials. Terms of the contract restrict Germany to domestic use of the acquired technical information until 1980. After that date, German TV manufacturers will be free to compete with those of the U.K. in production and export of Prestel-like hardware.

There is one significant difference in hardware between the British Prestel system and the Bildschirmtext as currently planned. The Bundespost does not plan to modify TV sets by building in VIDEOTEX modems. Rather, it has taken the stance that refresh-memory and character-generation LSI chips will become standard components of TV receivers and that low cost modems will become a standard part of telephone handsets.

There is considerable contention between German TV broadcasters and newspaper publishers over the issue of who can legally operate (and be responsible for) broadcast VIDEOTEX services. The legal and political issues are complicated, since laws governing newspapers (private organizations) and broadcasters (self-governing, non-profit public corporations) were not written to include the possibility of a service that combines the two functions.

The Bundespost is continuing development of the interactive Bildschirmtext system, arguing that the legal issues involving broadcast services do not concern operation of a Prestel-like system that makes use of telephone network transmission. Telephone regulation, however, is an issue for the German federal government, and the Bundespost is concentrating on technical developments and restricted trials until policy questions are resolved.

Surveys of the general public have indicated a relatively high level of acceptability of the proposed Bildschirmtext services. Projected initial costs to users of 450 Deutschmarks (\$300.00) was found acceptable to 30% of those

surveyed, while approximately twice that number of persons opted for monthly service charges for the services. From a report by Kanzlow, there will be as many as 1,000,000 subscribers for VIDEOTEX services by 1985.

The 1980 market test (now underway) will build up to 2000 private subscribers in Dusseldorf and 1000 business subscribers designated by Information Providers. A similar proportion of subscribers have been designated for Berlin. More than 1000 Information Providers will support this test.

France

Three VIDEOTEX systems (two broadcast and one interactive) have been under development in France since May 1977 at the CNET Research Center, which is jointly owned by the state telecommunications and broadcasting authorities. The systems are patterned after the British Ceefax/Oracle and Prestel services, with some technological differences in the mode of display. France is behind the U.K. in systems (and service) implementation, but appears to be well ahead of the rest of Western Europe.

Antiope

A broadcast system, Antiope is very similar to the U.K.'s Ceefax/Oracle, employing the same home TV receiver display format of 40 characters x 24 rows. The same character size and graphic display mode are used. The important differences between Antiope and the British systems lie in how the systems handle control characters and escape sequences. One reason for these somewhat involved variations is the French requirement for more characters in order to transmit and display information in several languages. The result is a more flexible display at the expense of a more complex subscriber decoder, which also requires more memory. The Antiope display methodology is the same as that of the French Titan interactive system; further detail is given in discussion of that system and in the discussions under Standards, which may be found in Section 3.

Titan

The Titan system is the French version of interactive VIDEOTEX. There are many similarities to the British Prestel system. The screen matrix format is also 40 characters per row times 24 rows. However, differences in the methods of coding and

receiver processing of incoming data make the Titan system both more flexible (more information and more detail can be displayed) and more complex and expensive. The heart of the Titan system is a more complex decoder and character generator which requires considerably greater memory store and a longer data transmission time for a given line.

The Titan uses the 7-bit ISO 646 (International ASCII) International Standard for character format. A key feature of the Titan coding system is the "escape" sequences. This is the equivalent of shifting a typewriter carriage from lower to upper case, providing entirely different sets of characters or function controls. It may also be considered analogous, in a Selectric typewriter, to on-command changing of typing elements (the balls) to provide entirely new sets of characters with differing type faces, accents, etc. The Titan (and Antiope) system's transmission codes for 7-bit systems allow for 128 combinations. Normally 32 of these combinations, the C-set, are used for central functions, and the G-set is used for character formation. In the Prestel system, the C-set of codes is used for display control characters--to produce such effects on the screen as red or blue characters or graphics. Problems with Prestel are that these command codes for graphics take up an empty space position on the screen (black or unfilled holes). This limitation of Prestel is eliminated or avoided in the Titan system. The French use a 16-bit memory word to describe the alphanumeric (7-bits) and the graphic shape or color, size of character, etc.

Advantages of the Titan character codes are the addition of some 30 additional characters, which provide about 30 or more control function shifts to other language sequences. This added flexibility and greater display control is more expensive due to need for more memory in the decoder box and a longer transmission time. The CCITT and ISO standards committees have held discussions on the issues of an international set of character codes since 1978. The standards questions are discussed elsewhere in this document.

Didon

This is a broadcast packet system, designed for the business market, used for transmitting Telex and fax as well as VIDEOTEX data. Any or all TV raster lines can be used for transmission; i.e., "spare" scan lines in the vertical blanking interval (as in the British Ceefax/Oracle) may be used, or the entire bandwidth

of a regular TV channel may be used when available. The French claim superiority for Didon, in comparison with Ceefax/Oracle, in several areas:

- . greater capacity in addressing capability as a general purpose data transmission service (a two-byte channel address compared to merely three bits, permitting address of up to 65,536 channels);
- . application independent; i.e., packet sizes are not fixed;
- . superior facilities for lost data detection and packet sequence checking; and
- . more forthright adaptability to various national TV systems.

Some of these differences between the French and British systems reflect basic incompatibilities in display flexibility and method of transmission. Considerable compromises would be necessary to achieve compatibility between the national systems. This may be difficult, considering the French requirement for multi-language transmission and the British plans for mass marketing of their present systems.

These problems are not limited to compatibility of broadcast systems. The obvious advantages of intranational compatibility between broadcast and interactive systems (common decoders and associated hardware) have offered strong incentives to both the French and British to standardize basic technology among their domestic systems. The struggle for international compatibility thus will be between families of systems. At the June meeting of CCITT, Study Group VIII has adopted both the Prestel and French Viewdata System standards with interworking compatibility to be achieved via the networks. It is to be noted that the U.S. is considering both the French and British systems in the CBS/EIA evaluation tests (see Section 2.6. of this report).

The Netherlands

In June 1978, Holland became the second country to contract with the U.K. for Prestel software and expertise. The Netherlands Postal and Telecommunications Authority (PTA) also ordered, at the same time, a GEC 4042 minicomputer for use with the initial interactive system. First public demonstrations were conducted in September 1978. Interim trials are scheduled through 1979 with the goal of beginning a public service for which no firm date has yet been announced.

Finland

Finland is conducting trials on an interactive system called Telset, based on the U.K.'s Prestel standard, modified to accommodate the additional characters of the Finnish and Swedish alphabets. They are using a DEC PDP-11/34 computer and both color and black-and-white TV sets as terminals.

The capabilities of Telset, as initially conceived, are limited compared to those of Prestel. Data base capacity is limited to some 10,000 pages, and sophisticated multiple-user interactions such as remote editing, customer response, and problem solving are not currently planned.

The service has been established by Finland's largest newspaper publishing group, Sanoma, in conjunction with Nokia, an electronics manufacturer, and the Helsinki Telephone Company, the country's largest of 66 telephone companies. Trials are coordinated with the Finnish PTT, which, in conjunction with Televerket in Sweden, has been responsible for modification of the U.K.-supplied decoders.

Denmark

The Danish TV network has been conducting a trial, since autumn 1977, of a broadcast VIDEOTEX system based on the U.K. standard. Some 55 pages of information were supplied on initial trials. As in the Finnish Telset system, character sets have been modified to accommodate the additional characters in the Danish alphabet.

In addition, the Danish PTT has obtained British interactive terminals in order to test the Prestel system using international telephone circuits.

Sweden

Sweden is developing and testing both broadcast and interactive systems. The Swedish Broadcasting Corporation has been conducting a small-scale trial of a broadcast system called Extratext since 1975. The system, conforming to the U.K. standard, is routinely used to transmit eight pages of information on one of the country's two regular TV channels. Developmental plans include transmission of continuously changing information on these eight pages, with one page allocated to captions for the deaf and the other seven allocated to seven southern European languages, for the benefit of immigrants. As in Germany, newspaper publishers are wary of a potential economic threat.

Televerket, the Swedish PTT, began in 1977 to conduct preliminary tests on interactive VIDEOTEX, using a small number of TVs purchased from the U.K. to access

Prestel via international telephone circuits. Although continuing the tests, Televerket decided in 1978 to develop its own system rather than purchase Prestel. At that time, the Swedish government pressed for a two-year public discussion on interactive VIDEOTEX, with particular emphasis on the privacy issues involved. Televerket considers that it will have developed a system of its own by the end of this period.

2.4 Japan

The Japanese now have several VIDEOTEX systems under study and development (HI-OVIS, 1976; HI-OVIS, 1979; Woolfe and Gaffner, 1978), some unique in concept, others quite similar to Prestel and Ceefax, the British interactive and broadcast systems. Because of the special requirements of the Japanese language which is pictorially represented by Kanji and Kana (Chinese ideographs and Japanese vowel and consonant representations, respectively), the Japanese systems have been developed to be quite innovative to overcome the resolution deficiencies of the Western systems. Among the many advanced systems are:

- . HI-OVIS - a broadband, experimental two-way video system using optical fiber transmission lines.
- . CAPTAINS - a character and pattern generating, telephone-interconnect, page-by-page system - similar to Prestel.
- . CIBS System - a high density, maximum storage system designed to handle Japanese ideographic characters with sufficient resolution.
- . VRS - a system using a broadband, dedicated two-way telephone transmission line to provide the 4.5 MHz capability to transmit real-time video as well as still picture information.
- . CCIS - A coaxial cable information service in Tama New Town (near Tokyo.)

The Japanese have pioneered in many forms of visual electronic information systems, and the above listing is typical of some of their more advanced systems, either now in field trial status or soon to be implemented. Discussed in greater detail are four of the unique systems, HI-OVIS, CCIS, TAMA New Town, and CIBS.

HI-OVIS

This high technology two-way video system is now about a year old and is an acronym for Higashi-Ikoma Optical Visual Information System. Broadband transmission is via optical fiber cable rather than coaxial cable. More than 150 families are

connected to a variety of services via conventional TV or two-way TV broadcast with some programming originating in the home. Other services (see Table 2) include movies, conventional CATV, and school and educational services as well as the large variety of informational services available through conventional (VIDEOTEX) data bank interface. The HI-OVIS has been a costly program to introduce and operate. The Japanese government, the Ministry of Post and Telecommunications (MPT), and the Living Information Development Association under the guidance of the Ministry of International Trade and Industry (MITI) have been supportive of this experiment. Estimates are that 20 to 30 million dollars were necessary to provide for the initial installation of equipment and staging of this elaborate experiment.

Some questions have been raised as to whether the Western governments or private industries in Europe or in the U.S. and Canada would be supportive of such a large undertaking as HI-OVIS with so little financial return in sight. The answer must be in the affirmative as in the case of Project Ida discussed later in this report.

The ambitious Ida system, sponsored by the Manitoba Telephone System (MTS) has many similarities to HI-OVIS although it does not allow for two-way, real-time video. Initially it will use coaxial cable rather than optical fiber cable. Project Ida (described in Section 2.5 of this report) gives evidence that elaborate systems are being devised to provide services well beyond the basic VIDEOTEX. The interesting comment in the brochures by the MTS sponsors of Ida is that they do expect to meet the cost of such services through suitable charges and tariffs resulting from multi-use of a common transmission medium and shared switch and control centers.

CCIS TAMA New Town Systems

This program has been operative since 1976, sponsored by the Ministry of International Trade and Industry (MITI) and the Nippon Telephone and Telegraph Public Corporation. Services provided via two-way coaxial cable include:

- . Broadcast TV
- . Pay TV
- . Participative TV programming
- . Broadcast polling
- . Facsimile printers
- . Flash captioning
- . Still picture requests (Interactive VIDEOTEX)
- . Memo copy
- . Others.

In addition to the usual video services, the CCIS system has allowed hard (printed) copy to be generated for certain subscribers with suitably installed equipment.

Outline of HI-OVIS Services

	kind of program	source of program	service method	terminal to be served at a time	video switch input line
service	re-transmission 9ch	VHF 6 UHF 3	share-a-program	all terminals	9
	local origination 14ch program studio production	general news 1 local information messages from public facilities leisure, cultural guide education school information	share-a-program	all terminals	1
	video information request service	music 6/68 leisure, cultural and educational program, educational service	share-a-program/ all terminals	4 terminals	3/4
	still picture information service	messages from public facilities 20 games (igo, shogi, etc.)	exclusive use	1 terminals	1
	character information service	general news 50 local information weather forecast railway timetable medical information addresses and telephone numbers of public facilities	share-a-program	all terminals	5
usage aid	program reservation 1ch	1	exclusive use	one terminal	1
	program guide 1ch	1	share-a-program	all terminals	1
	KR information 4ch	4			

Table 2. Typical HI-OVIS services. (Source: HI-OVIS, 1976).

Facsimile newspaper or memo printout are examples of such services. Broadcast polling would allow absentee participation in a town meeting forum, as well as receipt of instantaneous response to public issues and to surveys employing questions posed to allow for "yes or no" responses. The basic VIDEOTEX service from CCIS (similar to The British PRESTEL) has not been well-accepted in the CCIS system since neither alphanumeric definition nor character generation definition is of sufficiently high quality for ideographic display of the Japanese language. The CCIS system does not provide for a store-and-later present mode. It is real time whether sending animated (i.e., conventional) TV or still pictures; this analog transmission mode results in lowered picture resolution. The program was initiated with about 500 households and is expected to expand to 10,000 subscribers to generate interest among information providers and, in particular, advertisers. This type of support would bring in added revenues to help support the system.

Some problems listed in the initial two years of operation include: number of subscribers below critical volume; cost per month too high; privacy questions (in particular, polling as an intrusion); and problems relating to competition with publishing houses, newspapers, etc.

CAPTAINS

The following is a description of the design of a VIDEOTEX system known as the Character and Pattern Telephone Access Information Network system, abbreviated to the acronym CAPTAIN System. A review of the CAPTAIN design considerations in terms of meeting the unique requirements in Japan was given as a memorandum contribution to CCITT Study Group VIII (CCITT, 1978). This is an interactive type of system which has been introduced in Japan for field trial and meets the Japanese/Chinese needs for Kanji (Chinese Ideographs) and Kana (Japanese consonant and vowel combinations) rather than those of Western alphanumeric visual presentation. The field trials will be for 1,000 telephone subscribers. The sponsorship is by the Ministry of Post and Telecommunication (MPT) and Nippon Telephone and Telegraph, who are jointly developing the system. The CAPTAIN system will provide news, weather, guide information (travel, air, restaurants), etc. As with most other interactive systems, information will be displayed on a home television receiver with access to data banks via the telephone network.

The uniqueness of this system is in the format for presentation. The Japanese do not have an alphabet which is like our own. The characters consist of vowel and

consonant combinations used to form the words or phrases. The Japanese requirements are those that must be considered in terms of visual character presentation in order to provide the coding and the transmission for the written ideographs. To give some type of comparison between the Western alphanumerics and the Japanese character and graphic representation that might be required on a television screen, Western use of a 7-bit word provides a maximum of 128 combinations of alphanumerics and symbols. A small number of these (about 25 to 30 7-bit words) is required for housekeeping, input-output information, formatting, etc., and for providing various kinds of protocol, leaving approximately 100 combinations for information display. The comparison may then be made with the Japanese Kanji or Kana characters. Three thousand (3000) complex characters are required in a CAPTAIN system to provide the necessary combinations of consonants and vowels for information to be presented on the screen. Since it would be virtually impossible to provide this large number of character capabilities to the home or office terminals, the Japanese chose instead to provide translational capabilities at the computer centers themselves and to provide the information in the form of ideographs on the screen. The Japanese written language is provided by means of matrix images, or videopatterns, instead of discrete alphanumerics. Thus no character generator is provided at the TV receiver, since the information is translated into video patterns by the dot matrix imaging technique.

The CAPTAIN system design lists a number of advantages:

- (1) It is possible to transmit minute image information - high detail not restricted except by receiver capabilities.
- (2) Since character generation is at the computer center and no further translation is needed, it is possible to use any of many character sets. The reception at the receiver is transparent to what is sent.
- (3) The terminal becomes simple and flexible.

Other details of the CAPTAIN System are shown in the accompanying diagram, Figure 6. The heart of the system is the CAPTAIN center, which controls the flow of data to and from the customer terminal and telephone. Information and requests are processed from the input information terminal and data base center via the CAPTAIN center. The most important function of the CAPTAIN center, one which differs from conventional VIDEOTEX systems, is the transformation of retrieved data into video patterns which can then be displayed on the TV screen in dot-matrix

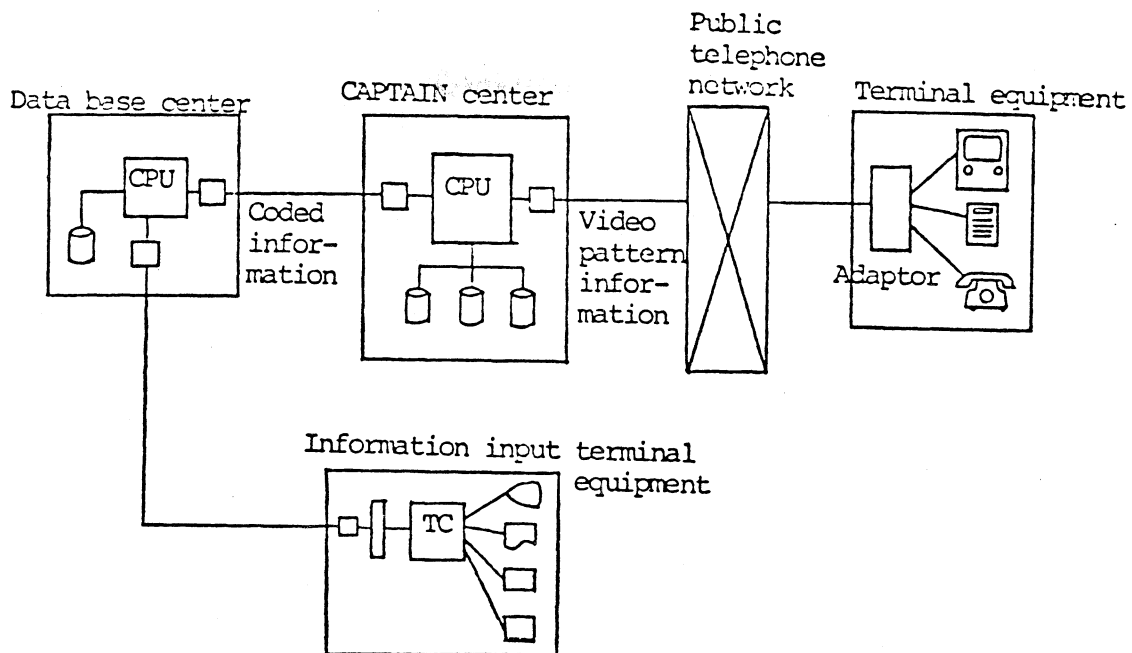

Figure 6. Japanese CAPTAIN system architecture.

form. Transmission from data center to the CAPTAIN center is over a 4800 bit/second circuit; transmission from the control center to the terminal is via public switched telephone network.

New and updated data are introduced into the CAPTAIN center and data storage center from an elaborate keyboard. Either a facsimile transmitter or a Kanji character keyboard is used to provide data entry from a few thousand characters laid out in a two-dimensional matrix. The CAPTAIN center then encodes the new data for storage or transmission. In order to present Western (Roman alphabet) data input, 96 alphanumeric and symbol characters may be directly entered from the same or an auxiliary keyboard.

Both the CAPTAIN system and the Canadian Telidon VIDEOTEX provide reasonably high resolution on the screen in order to display good quality pictorials and graphics. The added cost and complexity of the CAPTAIN system is due to the more elaborate data storage and processing center (the CAPTAIN center) with some added

memory requirements at the user terminal. This added cost in turn provides a highly flexible and relatively uncomplicated receiver system with the overall control system costs distributed among a large number of users.

The Telidon system, (described in the following section), on the other hand, requires additional encoding sophistication, a more elaborate and more expensive keypad and decoder at the user terminal, as well as an added or built in micro-processor. Also with a more complex system, a somewhat longer time is necessary to receive and display the higher resolution graphics available with this system. The results for the customer are a greater initial outlay for each terminal in order to gain the highly improved resolution in graphics and pictorial representation. Both systems offer far more flexibility and information on the screen per "page" than do the typical systems being used in Europe, such as the Prestel or Antiope systems, or for those contemplated for introduction here in the states.

This brief discussion of VIDEOTEX and special visual information services to private subscribers in Japan indicates that Japanese government and industry have taken aggressive roles in pushing these new technologies and services. This has been the case, even though financial payoffs have not been easy to forecast or realize as early objectives for such sophisticated and costly services. It is to be observed that, in sponsorship for the several kinds of systems, the key government organizations have been the Ministry of International Trade and Industry, Nippon Telegraph and Telephone, and the Ministry of Post and Telecommunications. Private industry, of course, has been given assignments for developing and providing the home TV terminals, specialized modems, and the broadcast or interactive communication links. It is not clear how the development costs by the manufacturers have been met or can be met under a major expansion of the system. It is reasonable to expect, however, that with such heavy government participation, some of the significant R&D and start-up costs may have been met through partial subsidies from the Japanese government.

2.5. Canada

The Canadian telecommunication services are provided through a highly varied number of organizations, quite unlike their European counterparts. A possible structure for the Videotex Industry in Canada, was offered by A. R. Kaye, Dept. of Communications in the Proceedings, CCITT Symposium (1979), p. 159. The mixture is

that of public and private business enterprises, monopoly and competitive services. Regulation is both at the federal and at the province levels. Interworking and interconnectability is provided through an arrangement among the operating companies, called the Trans-Canada Telephone System (TCTS). It is through this organization that interprovince services and interoperability questions are settled. Companies making up the national data networks and services interact through a separate consortium called Canadian National and Canadian Pacific Telecommunication Companies (CNCPT). These organizations own and operate the various data and packet switched networks employed for transmission of the data services. It is expected, according to A. R. Kaye, that both broadcast and interactive VIDEOTEX services in Canada will develop as competitive private enterprises subject to the demands of the marketplace. Services may initially be delivered as in Europe via the telephone network or by direct broadcast. However it is expected that delivery may eventually be via cable TV, specialized telecommunication networks, packet switched networks, or combination of many existing services.

It is not surprising then that in Canada a number of information services are coming into being, some closely resembling European VIDEOTEX systems, such as TELIDON, and others more like HI-OVIS or CAPTAINS in Japan.

The most frequently publicized among these systems and nearest to operation are Telidon, MARK I and MARK II, and Project IDA, which are described in some detail in the following discussion.

Telidon

Telidon is one of a number of VIDEOTEX systems under development by the Communication Research Centre, Canadian Department of Communications (Bown, et al., 1978). The concepts for Telidon cover both interactive and broadcast VIDEOTEX services. Telidon provides a method of coding and receiver design that makes it possible to take advantage of the maximum resolution of TV receivers (and/or high resolution video terminals), as compared to the lower resolution possible with character-oriented graphic displays.

Present TV receivers modified for display of VIDEOTEX information have a character generator either built-in or contained in a separate module (usually the key-pad). The information taken from the video or storage unit is presented to

the character generator circuitry in the form of a series of 7-bit words, which are interpreted as specially identified alphanumeric characters or symbols by the character generator. These are then displayed on the screen in the form of text or graphics. Since the smallest elements from which pictures or graphics can be displayed are the character elements themselves, the resolution for such systems are frozen into the design. Such systems may be called alpha-mosaic displays.

The Canadian Telidon solution to overcoming the limitations on resolution, and to making the system receiver-independent, is through the use of a method of coding known as Picture Description Information (PDI). The intent is to make the resolution of stored images virtually independent of the terminals, networks, or data base architectures. In this system (PDI), the content of images is described in the form of geometric bits: lines, arcs, dots, and polygons, plus control information for positioning the elements with great accuracy on the screen. (The Telidon claim is for a positioning accuracy of \pm one part in 2048.) The resolution of such displays greatly exceeds that of present day receivers, a desirable situation. Screen resolution of the PDI system has been shown to be 960 x 1280 picture elements. Graphic presentation with bit-map memory built into the terminals can give rise to high quality maps or pictorial representations. Present day color TV receivers, well-focused, are capable of resolving approximately 240 x 320 elements.

Coding is in the form of 8-bit words (bytes). One bit of each word is used to provide parity check, and is in compliance with the requirements for network transmission. Since there are a large number of control commands in the graphic mode, text or alphanumeric characters are "printed-out" by coded command which shifts the system into a character-oriented mode or back into a graphic mode as required.

Terminal circuitry has a greater complexity than for the character-oriented mode of operation alone. It is likely that in the second generation design of Telidon systems a microprocessor will be incorporated which, on the basis of received coded information, will perform the necessary shift to the appropriate display memory code.

Circuit designs for a Telidon system with and without high resolution graphics are shown in Figures 7-a and 7-b. The presentation quality of some of the earlier results using bit-map memory as compared to character-oriented memory are shown in Figure 8. Figure 9-a shows the terminal display capability for alpha-geometric as compared to alpha-mosaic descriptors. Figure 9-b utilizes the descriptive power of the alpha-geometric mode.

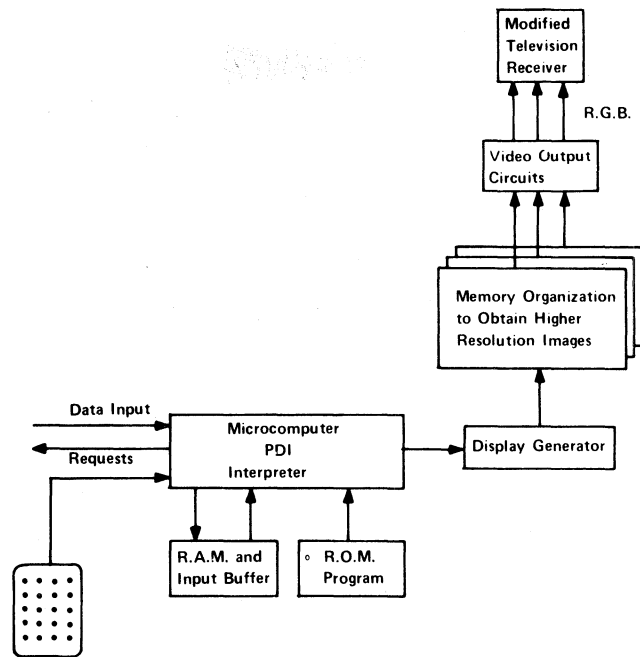

a. *Telidon Terminal With Bit-Map Memory for High Quality Graphics*

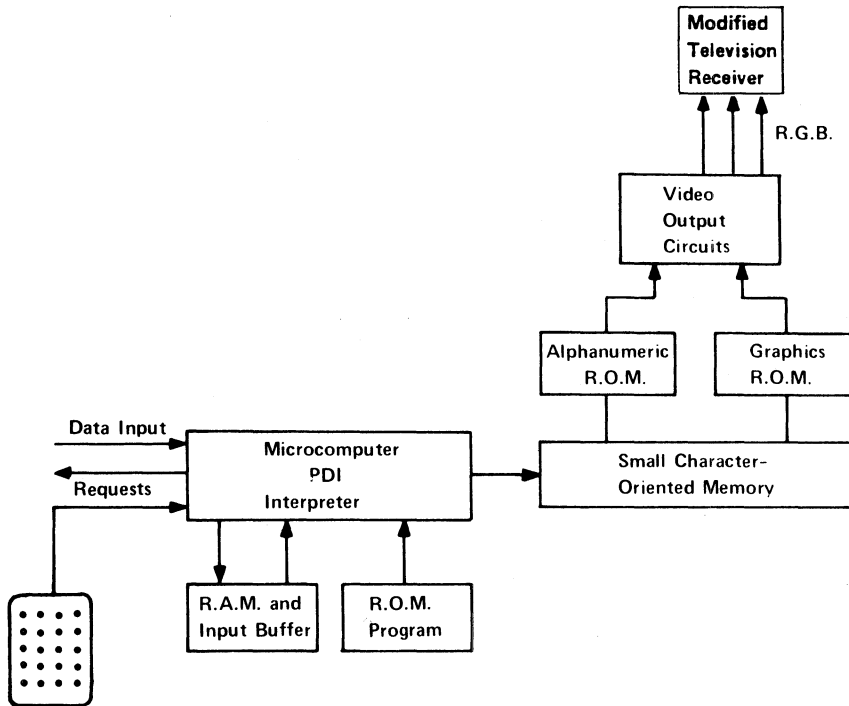

b. *Telidon Terminal With Character-Oriented Memory for Good Quality Text but Limited Graphics*

Figure 7. Canadian Telidon circuit designs with and without high resolution graphics. (Source: Communications Research Centre, 1978).



Map of Canada Display on Telidon Terminal Containing Bit-Map Memory



Map of Canada Display on Videotex Terminal Containing Character-Oriented Memory

Figure 8. Comparison of Telidon bit-map and mosiac memory display.

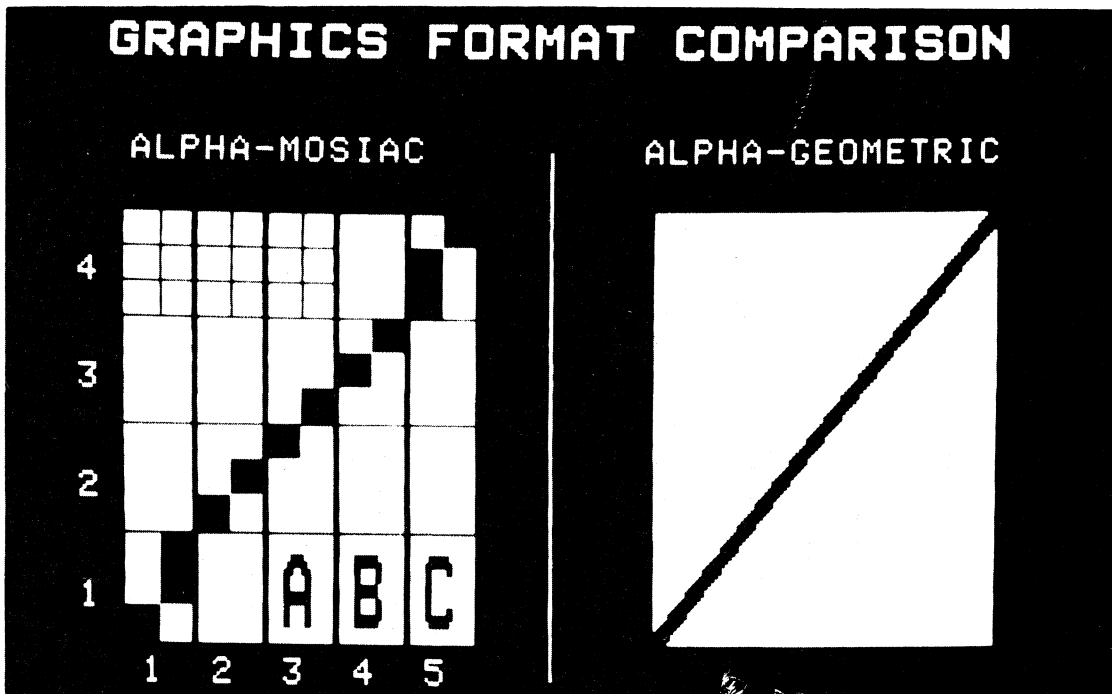

Figure 9a. Comparison of alpha-mosaic and alpha-geometric displays.

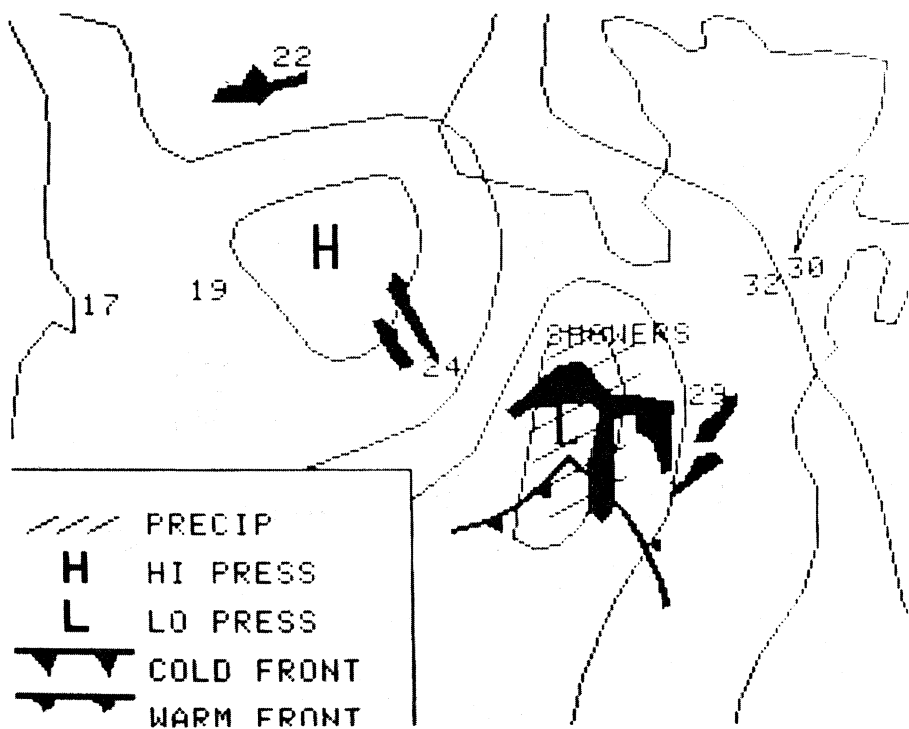

Figure 9b. Example of descriptive power of Telidon alpha-geometric mode. (Source: Communications Research Centre, 1978).

Some conclusions are drawn by the authors of the Telidon report (Bown, et al., 1978). The use of the PDI codes and some added processing circuitry in VIDEOTEX systems may permit an increase of resolution of pictorial graphic displays from 60 x 80 (4800) picture elements for well designed character-oriented terminals (Prestel, Antiope, etc.) to 240 x 320 (76,800) picture elements on a standard home color receiver outfitted with the PDI codes and circuitry. For a high resolution business terminal, the same coded information using the PDI codes would increase the resolution to 968 x 1280 (1,228,800) picture elements. The number of bytes to fill out a frame may vary from 500 bytes to 3000 bytes, depending upon the complexity and detail contained in the image.

On the basis of the need by the Japanese for high quality graphics because of the linguistic or pictorial character of the written language, and by Canada in connection with their Telidon system, a good deal of attention is now being devoted to developing consistent standards internationally for VIDEOTEX coding. A separate section in this report is devoted to this topic.

Project Ida

Among the more elaborate of the VIDEOTEX Systems soon to be implemented in North America on a field trial basis is a service described (Press Release and Brochure, 1979) under the trade names Project Ida or the "Home of the Future." It is a development of the Manitoba Telephone System (MTS). (Project Ida is not an acronym but is in memory of the first woman telephone operator in Manitoba, Canada.) Some 50 homes in South Headingley, Manitoba will be offered interactive VIDEOTEX services. In addition to VIDEOTEX, the services will include closed circuit TV, TV-on-request - such as movies, sporting events, cultural and educational activities. Gas and water meters will be read remotely and automatically. Those households participating in the field trials, plus approximately an additional 50 homes, will be offered a protection system for automatic fire alarm reporting and instantaneous relaying of pertinent information to the local fire departments. Broad bandwidth coaxial cable is the central technological feature that will make available a variety of services such as broadband and narrowband video, digital telephone, and VIDEOTEX. This cable will connect individual homes to service centers through the central switching and distribution office. A mini-computer and distribution terminal will control billing services needed to

integrate such a variety of services over one facility. It is the belief of the sponsors that the high costs of initial installation in a rural community can be overcome by providing all the available services over one electronic highway. The aggregate revenue derived from all services would then make it possible to pay for the costs of the network.

The Manitoba Telephone System (MTS) is thinking ahead to other innovations in future telecommunication services and technologies to meet the needs of its customers. MTS is now planning another telecommunication system trial scheduled for 1981, in Elie, Manitoba. Here MTS will install an integrated telecommunication system called "Farm of the Future" using optical fiber cable to provide specific farm information as well as many of the services mentioned above.

Contemplated uses of the Ida networks are listed in Table 3. Information and data entries are expected to be provided by private or independent suppliers (see Table 4) who would be sharing the use of the MTS network. Shown in Figure 10 is a schematic of a projected system architecture for Ida.

2.6. The United States

The U.S. has pioneered in several highly specialized areas of information retrieval using various combinations of telecommunication media, resulting in systems which may be considered as subsets of what is termed "VIDEOTEX". Notable among such domestic systems are the sophisticated PLATO educational tool, the highly efficient airlines reservation systems, and the several nationwide data banks accessed by a rapidly growing number of local libraries, both government and public.

U. S. companies, however, have moved more cautiously toward the introduction of information retrieval services for personal or home use. We have lagged behind several countries, notably Japan, the United Kingdom, France, and Canada, in the design and (in several cases as noted earlier in this section) implementation of state-of-the-art information distribution systems whose services are addressed to the presumed needs of the home user. Based upon the number of public announcements of proposed new services throughout 1979 and in the first half of 1980, this situation appears to be changing drastically and conceivably very soon.

A system quite similar to Telidon was demonstrated at the CCITT Colloquium, Montreal in June 1980. General Telephone and Electronics Company has publicly announced an interactive business-type VIDEOTEX based on the Prestel system.

DIGITAL TELEPHONE SERVICE
VOICE MAIL
TELEPHONE MESSAGE RECORDING & RETRIEVAL
FIRE, INTRUSION AND MEDICAL ALARMS
TEMPERATURE ALARM FOR DEEP-FREEZE MALFUNCTION
HOLD UP IN PROGRESS ALARMS
REMOTE METER READING FOR POWER, GAS, WATER
MONO MUSIC, STEREO MUSIC AND VOICE DISTRIBUTION
TELESHOPPING
TWO-WAY INTERACTIVE VIDEO SCHOOL
ELECTRONIC MAIL
FACSIMILE
ELECTRONIC NEWSPAPERS
YELLOW PAGES
LIBRARY SERVICES
STOCKS AND SECURITIES INFORMATION
POLLING AND AUCTION SYSTEMS
RESTAURANT LISTINGS
GUIDE TO NEW AND USED CARS
GENERAL GOVERNMENT INFORMATION
INCOME TAX ADVICE
ELECTRONIC FUNDS TRANSFER
CABLE TELEVISION DISTRIBUTION
EDUCATIONAL TELEVISION
PAY TV
TELEVIDEO PHONE
REAL ESTATE LISTINGS
ETC.

Table 3. Possible uses of Canadian Project Ida.

ALARM REPORTING SERVICES

Amplitrol Electronics Limited
Metropolitan Security
Protelec Limited
SDS Technical Devices Limited
Teleguard Limited
Winnipeg Fire Department

DESIGNERS AND MANUFACTURERS

Omnitel - Interdiscom Systems Limited
Telidon - Department of Communications

METER READING

Greater Winnipeg Gas Company
Manitoba Hydro

MUSIC SERVICES

CPMS Cable Stereo

VIDEO SERVICES

Select-A-Vision Inc.

VIDEOTEX SERVICES

Winnipeg Free Press
Winnipeg Tribune
Globe and Mail
FP Publications
Southam Press
Toronto Star
Cybershare Limited
Home Information Inc.
Yellow Pages

DIGITAL TELEPHONE SERVICE

Manitoba Telephone System

Table 4. Participants in Project Ida.

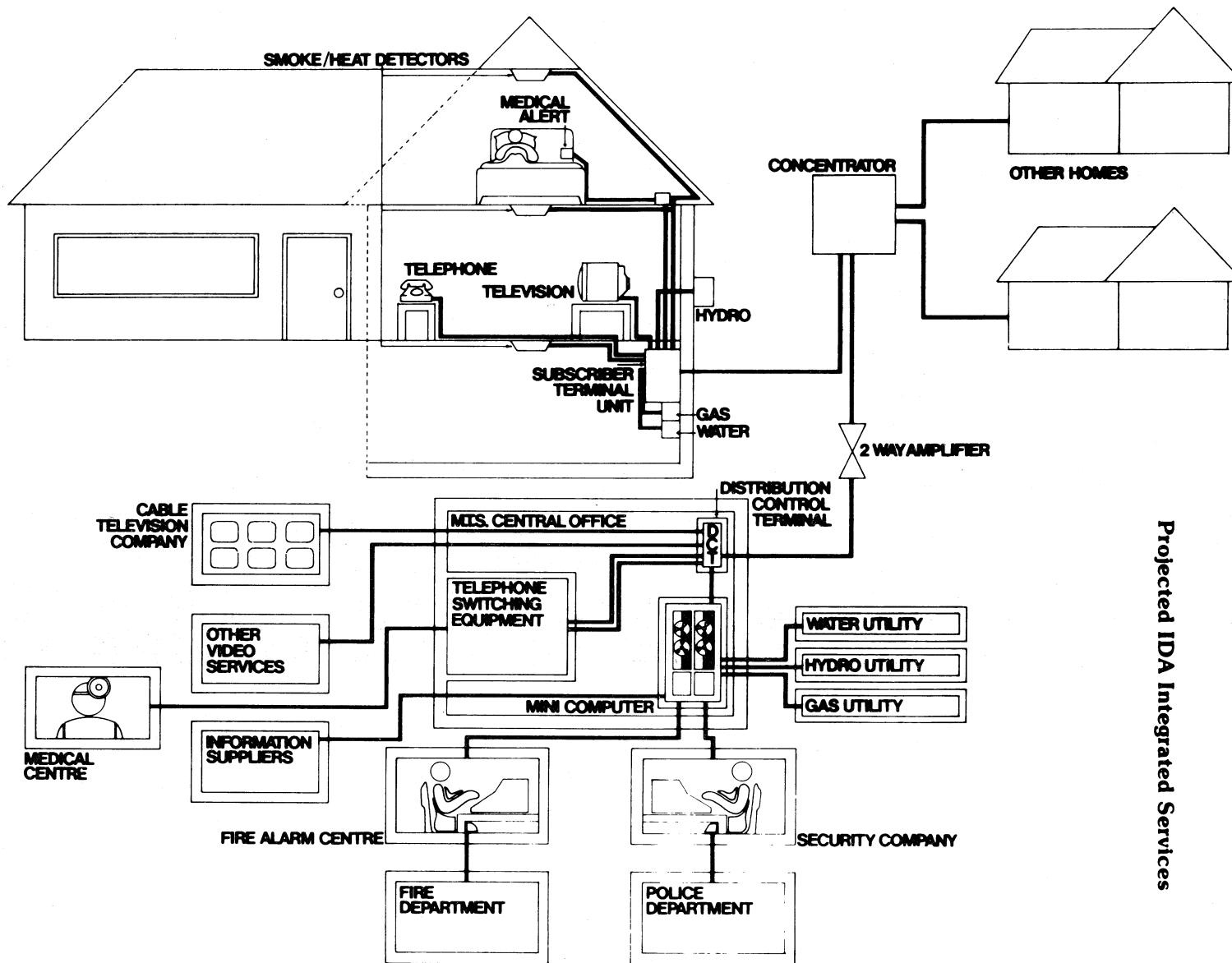

Projected IDA Integrated Services

Figure 10. Proposed system architecture for Canadian Project Ida.

Also, the Telidon technology has been chosen for the first U.S. consumer trial of broadcast VIDEOTEX (teletext), to be conducted at the Public Broadcast System station, WEMA Washington, D.C. starting in late 1980. (News Release, Department of Communications Information Services, June 11, 1980.) This trial will be co-sponsored by the National Science Foundation, National Telecommunications and Information Administration, and the Department of Health, Education, and Welfare.

The U.S. Dept. of Agriculture, with technical assistance from the National Weather Service and the Institute for Telecommunication Sciences, is working with the State of Kentucky in testing a prototype service, also via the telephone net, to provide up-to-date weather, crop, and financial information to the farmer. The U.K. has also formed an American subsidiary to market one version of their interactive Viewdata-type system both in the U.S. and in Canada.

Other proposed interactive systems, some already undergoing limited subscriber testing, offer home "personal" computer access to large data banks varying from specialized information sources such as financial services to broad, consumer-oriented "libraries." Proposed transmission media include the switched telephone network, FM subcarrier, coaxial CATV systems, satellite relay, and packet-switched data networks.

Some representative proposed new systems are briefly discussed in the following pages. The PLATO system is certainly not new; it is summarized, however, because (a) it exemplifies how the U.S. has applied pertinent technology to produce a highly successful interactive service and, (b) PLATO sponsors have announced an offering of this previously educationally-oriented system in the form of a commercial service. Consumer-oriented systems and services have received primary but not necessarily exclusive concern of this report; a few services directed toward business markets are now being emphasized by the system provider. These systems are not technologically limited to the non-residential user. As noted, the GTE-Viewdata System is presently being offered for business users only.

PLATO (Programmed Logic for Automated Teaching Operations)

The PLATO system was developed originally (as the result of a research effort begun in 1960) as a highly interactive, innovative teaching tool: computer → smart terminal → student. It has more recently been described by its sponsor, the

University of Illinois, as also providing a potentially effective business and social service information medium for the public (Lyman, 1978). Three aspects of PLATO are said to make it a highly desirable and flexible system:

- (1) the high speed and powerful large central computer and peripherals;
- (2) the sophisticated, user-oriented terminal equipment (estimated cost of user hardware: \$5000 to \$8000); and
- (3) seventeen years of educationally-oriented software development and experience.

Software and methods of interaction provide for a high level of computer communications. High resolution graphics and considerably greater alphanumeric content are possible (both on the standard TV receiver screen and on the plasma panel display device invented for this system) as compared to Prestel-type systems.

The PLATO system is now mature, involving some 1700 terminals dispersed among 60 universities, high schools, government and private organizations. Some 5000 hours of stored program can be called upon from about 1200 data bases including financial, social, legal, and computational services. The PLATO system is now moving into its next advanced stage: to provide personalized services employing communication media to provide legal, medical, career planning, financial, entertainment, electronic mail, and word processing services, just to name a few. It is a heavily used system as noted by the statistics. The present system is accessed for approximately one million hours per year. To the end of 1978, more than 5 million hours have been logged. (See Figure 11.) It has also gone commercial via CDC (Control Data Corp.).

For businesses which can afford the PLATO service, it may prove to be the most valuable interactive system available today with the greatest long term usefulness.

Project Green Thumb

This pilot program, currently nearing the conclusion of its trial phase, is a government-sponsored experiment using an intermittently interactive VIDEOTEX system to explore the feasibility of providing rapidly updated weather and agricultural data directly to the farmer, in his home. The system resembles the Prestel continuously interactive systems in that the user is equipped with a microprocessor-controlled encoder/decoder/memory module, containing a numeric keypad, which interfaces his home TV receiver and telephone. Information access is via the switched

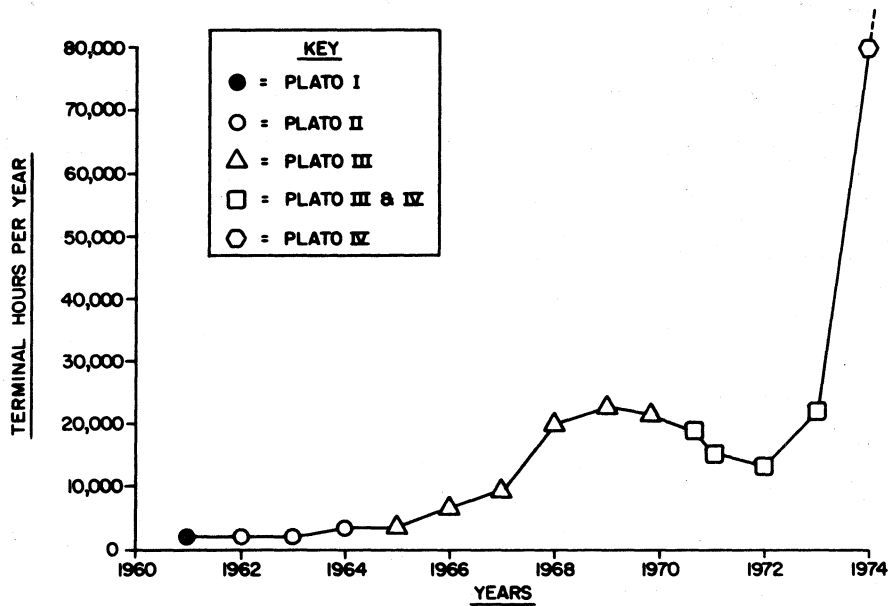

a. PLATO System Usage - 1960 to 1974 - Students Only

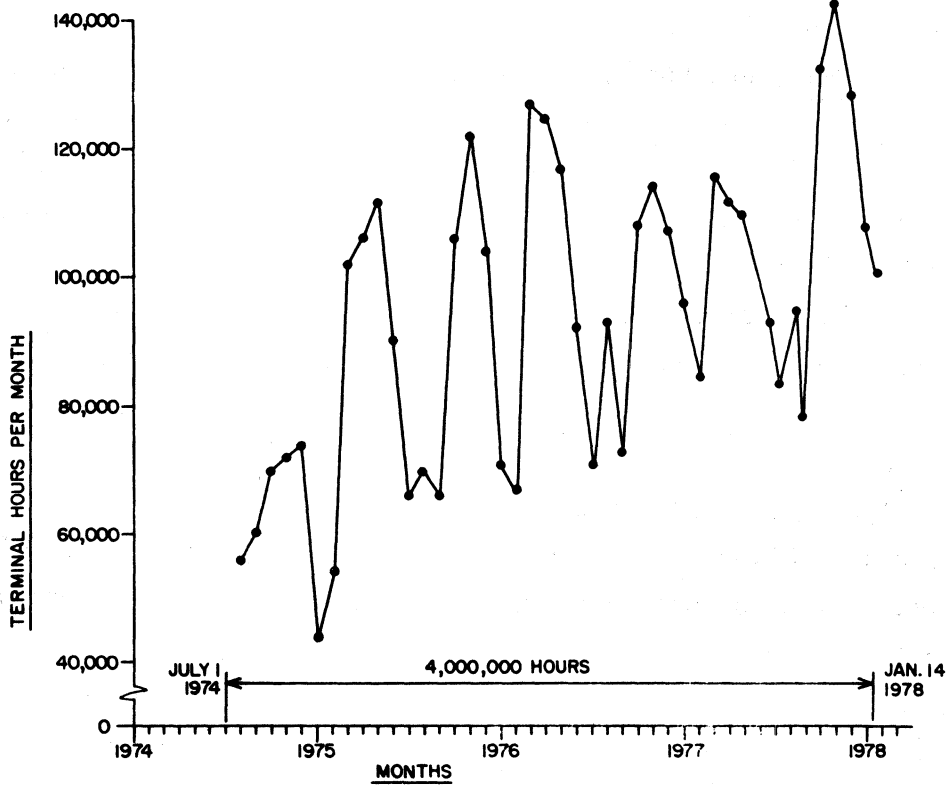

b. PLATO IV System Usage - July 1, 1974 to Feb 1, 1978 - Students and Authors

Figure 11. PLATO systems usage.

telephone network to a local (county) data bank, which is periodically updated from a regional (state) host computer, which "sorts" data by county. Each county agricultural agent may also input data at the local level.

There are two primary functional differences from the Prestel-type system: the TV receiver for Green Thumb does not require modification and telephone line transmission is effected by a "dump and disconnect" feature in the interface module circuitry; i.e., the connection is automatically broken after the user-selected information is stored at his terminal. This mode of operation has been selected by the system designer in order to minimize connect time and consequently lessen network and computer blocking problems. Section 5 of this report is devoted to a discussion of the impact of interactive systems on the local loop; Project Green Thumb is used as the example for a preliminary analysis.

Farmers subscribing to the Green Thumb service may obtain information directly from the county computer on a 24-hour basis. To access the system, the farmer simply turns on his TV receiver, keyboards his "page" selections, and then dials a special access number in the local county agent's office. By depressing the SEND key on his "Green Thumb box," he effects transmission for a requested set of information which is loaded from computer into the memory of the farmer's encoder/decoder module at 30 characters per second. The telephone line is then automatically disconnected and available for another user. The stored information may be reviewed by the farmer at his leisure.

Requirements for the prototype "Green Thumb box" follow:

1. Provide modulated video to color or black and white television sets at the antenna terminal.
2. Provide for transmission of digital data, at 300 baud, over the switched access telephone network. The mode shall interface with the telephone per legal requirements regarding design, construction, and registration.
3. A general purpose microprocessor (with software in a separate ROM) to implement local control of the key pad, video, and telephone communication functions.
4. A character generator capable of displaying the upper case ASCII 64-character set, in 16 rows of 32 characters per row, and square point graphics in 64 horizontal and 48 vertical positions. Graphic

points and alphanumerics must be displayable simultaneously. The spots shall either display in at least four readily-distinguishable intensity (gray) levels on B&W sets or at least four colors on color TVs. An alternate display mode shall provide spots only on a 128 x 96 matrix with at least two colors or intermediate color levels. In this mode, no direct ASCII characters need to be displayed.

5. A minimum of 4k bytes (4,096 characters) shall be provided to store messages.
6. A 16-key pad, including the digits 0-9, and 6 functional keys, is required. The functional keys will include PREVIOUS PAGE, CLEAR, NEXT PAGE, SEND, * , and # .
7. ASCII-encoded data shall be transmitted into the Green Thumb box's memory, and ASCII will be outputted from the box in response to key pad entry for control information exchange.

Project Green Thumb was initiated in partial response to a variety of sobering statistics: food and fiber loss in excess of one billion dollars occur annually in the United States because of adverse weather effects, crop diseases, and non-optimal planting and harvesting time. Dissemination of weather and agriculture market information has changed very little in the last 20 years. In the interim, technology has developed to a point where the government and other agencies have a large amount of data stored in computer accessible form which could dramatically impact large groups of our society, provided the mechanism is available to transport and translate the data into timely, useful information.

In mid-1978, the U.S. Department of Agriculture/Science and Education Administration - Extension (USDA/SEA-E) with the support and assistance of the National Weather Service (U.S. Department of Commerce/NOAA) drew up plans for a prototype experiment called Project Green Thumb, to test the feasibility of having state extension personnel operate a computerized data network for dissemination of farm and weather information directly into the farmer's home from a computer data bank. The State of Kentucky was selected for the test, and the state in turn selected two counties (Todd and Shelby) as test sites for the equipment demonstration. Each county selected 100 farmers to participate in the tests to be conducted by the University of Kentucky Cooperative Extension Service under a cooperative

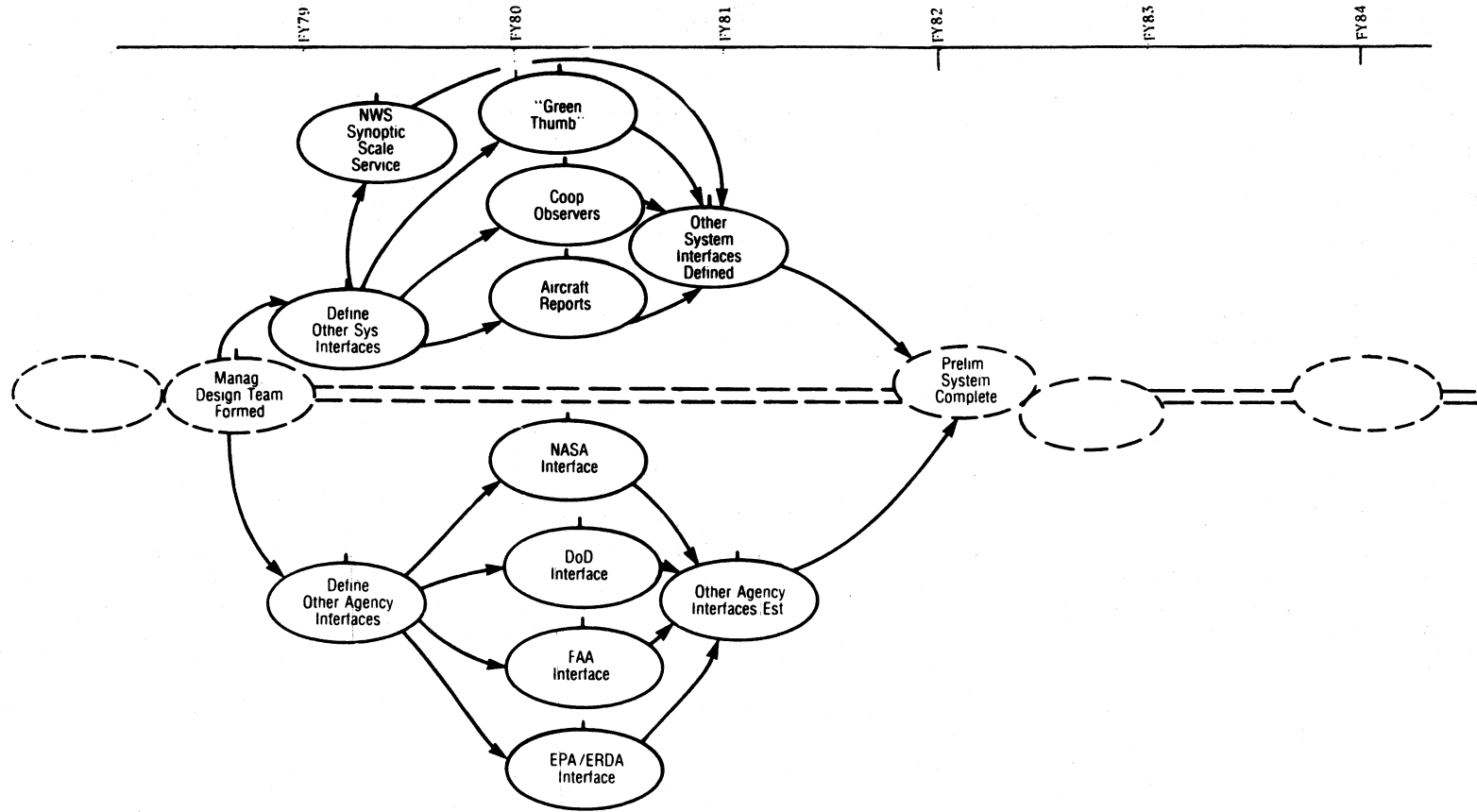

Figure 12. Proposed PROFS schedule for interfaces with external systems.

agreement with SEA-E and with the support of NWS. Technical consultation in the telecommunications area was provided by the Institute for Telecommunication Sciences (U.S. Department of Commerce, National Telecommunications and Information Administration). The pilot program consisted of two phases: Phase I, a system transmission simulation employing a single terminal, was satisfactorily completed by early 1979. Phase II, testing feasibility of the system over the two-county area, has been well underway since March 1980 and will cover at least the full growing season, ending December 31, 1980.

Stated goals for the pilot program are:

- (1) testing the feasibility of operating a computerized system for dissemination of weather, market, and other agricultural production and management information on a day-to-day basis;
- (2) development of a prototype software support system for the test; and
- (3) providing test parameter data to evaluate the usefulness and acceptability of the information and information dissemination system.

The direct federal cost of the two-county project will be covered by cooperative agreement with the University of Kentucky. This test will help to establish the cost and benefits of a 150-county test and an estimate of a national system. Based on a preliminary assessment, it appears that a national Green Thumb system would cost between \$30 and \$50 million the first year of the program and \$9 to \$15 million annually in the subsequent years. It is anticipated that the major part of the cost beyond development would be borne by state and county governments, including all operational and maintenance costs in the states.

PROFS (Prototype Regional Observing and Forecasting Service)-Concept

The Prototype Regional Observing and Forecasting Service (PROFS) concept (Beran et al., 1978) has the ultimate goal of providing the nation with radically improved local-scale weather services. In order to accomplish this goal, recent progress in observing and forecasting methods, data processing techniques, and modes of dissemination will be integrated to produce improved forecast accuracy and responsiveness to local weather conditions. This new capability is designed to fill the local service gap that is a primary reason for substantial weather-caused loss of life and for economic inefficiencies, and will become an integral part of existing synoptic scale services. Figure 12 shows the tentative schedule for establishment of interfaces with other systems.

The PROFS service has been considering use of a VIDEOTEX system such as Green Thumb for weather service dissemination to users as opposed to creation of a unique distribution network. Weather dissemination may work equally well with the application of broadcast VIDEOTEX services for widespread dissemination of meteorological information.

Corporate Insac (Viewdata)

The British Post Office's Insac has recently made its entry into the U.S. interactive VIDEOTEX market through the offering of a private business system called Viewdata, that would provide services to businesses and, eventually, to the general public through licensing of firms within the U.S. and Canada. Unlike Prestel or the Canadian Department of Communications' Telidon, transmission will be through a packet switched network capable of interface via standard RS 232-compatible terminal ports. Seven-color display plus graphics will be available through this system.

Initially, the U.S. Viewdata system has been designed for the business community. The offerings will include commercial services to manufacturers and corporate centers: immediate information concerning accounting, cash flow, ordering, raw materials, finished inventories, sales, and other indicators of the vitality of a business.

System architectures will allow for dedicated leased lines for packet entry from the data centers, large conventional computers (e.g., IBM 370), mainframes or regional dedicated multipoint entry minicomputers. A schematic of a corporate View-data system by Insac is shown in Figure 13. Pricing schedules were suggested by Insac (Viewdata) for the use of the network and terminals as shown in Table 5.

Expected use for Insac (Viewdata) is as a business terminal, a company tool for controlling and ordering out of inventory, selection of purchases, provisions for hotel and public service listing, airline schedules, and the like. It is intended to provide a guide and constantly updated reference rather than to replace the functions of agencies that perform the specialized customer services. In one contemplated installation, the services performed will be entirely intrabuilding or intracompany rather than accessing of outside computer and data center facilities. Included in the data store for such "inside" terminals will be:

- . statements relating to company regulations,
- . sales and production performance,

VIEWDATA COSTS

Color Terminal with Alpha-Numeric Keyboard	:	\$100 mo.
First 15 Minutes use per Terminal per Day	:	No Charge
Terminal Usage in Excess of 15 Minutes per Day	:	\$2 to \$4 per Hour
Charge for Storing One Page (64 characters x 32 lines)	:	\$1 per Year

Table 5. Corporate Viewdata: Tentative User Charges (Source: Insac).

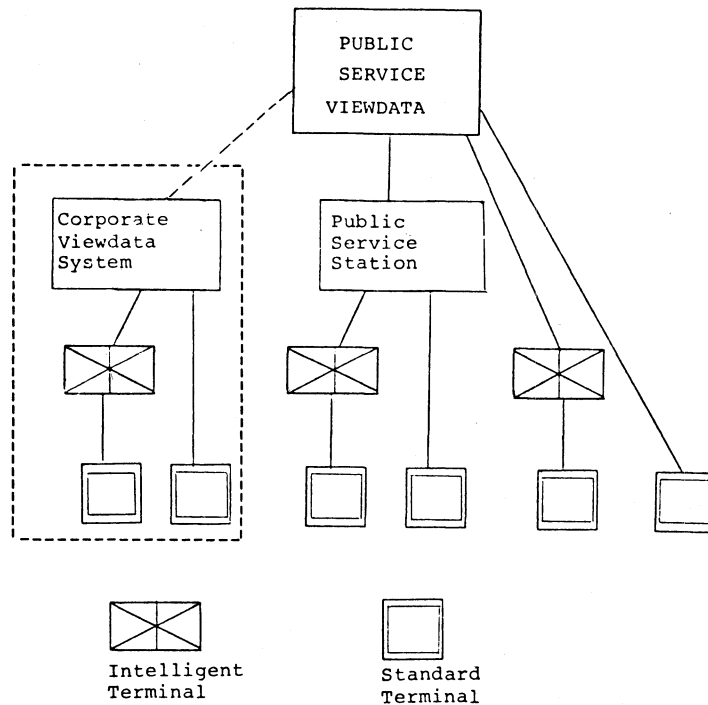

Figure 13. Proposed Insac Corporate Viewdata system.

- . staff and in-house news item,
- . various production listings,
- . stock levels,
- . product prices, and
- . interoffice memo traffic.

The Insac service venture into commercial and manufacturing and applications provides a realistic approach for early entry into interactive U.S. services. It can be adapted to specialized business purposes without the concern with widespread acceptance by a much larger public or home-user group. Whereas the general public is likely to accept a broadcast terminal one-time payment of \$100 to \$200, the resistance to duplex or interactive systems may be much greater. Here the customer - or consumer - would be looking at periodic costs: added telephone service costs plus page costs. To be noted is the emphasis upon the variety of manufacturers' or business functions to be offered by Insac. It would appear to employ sophisticated or intelligent terminals not unlike those of systems already attached to major computer nodes.

General Telephone and Electronics (GTE) has been licensed by Insac to provide this publicly oriented Prestel service for residential or business use. The licensing agreements give to GTE exclusive public rights in the U.S. and Canada for providing Prestel services, modified to meet the Western Hemisphere 525 line TV display standards. Of particular interest is also the offering of software data packages, by Insac, already converted to allow for the U.S. formatting and scan rates. In limited trials in various regions within the U.S. and Canada, GTE is seeking marketing information for services using the Prestel system.

Broadcast VIDEOTEX TV Field Trials

By early summer 1980, four U.S. commercial and one PBS television station had announced that they had either begun preliminary testing of broadcast VIDEOTEX services or plan to do so in the immediate future. These stations are KMOX-TV, St. Louis; KSL-TV, Salt Lake City; and Micro-TV, Philadelphia.

CBS Teletext Trials

A test program transmitting Teletext signals was inaugurated in spring 1978 by KMOX-TV, St. Louis (a CBS owned station). Tests were made at a representative number of locations in the KMOX-TV viewing area to provide a basis for evaluation

of the British Ceefax-type of system and the French Antiope system. Some 23 receiver sites were chosen to evaluate the quality of Teletext data as received by broadcast, and to determine degradation of picture quality of TV programmed material being broadcast as part of the local or network programming. Evaluations of the tests were set forth in a series of reports of Teletext field trials. The initial report was Phase I.

Additional tests were performed after broadening the transmission to include UHF broadcasts of Videotex over station KDNL-TV, St. Louis. Teletext signals were also allowed to be transmitted over the network with options by affiliates to either remove the teletext signals from the video subcarrier or to allow the signals to be received and evaluated at numbers of test sites throughout the country. In the latter case, TV receiver manufacturers could also evaluate the effects of the Teletext received on the broadcast TV programs. The results of the CBS tests were published in two sets of reports: entitled Teletext Field Trials, Phase II and Phase III.

Conclusions gathered from the Teletext field trials within high field strength areas surrounding St. Louis are that Teletext performance was quite good at all transmitted bit rates and was still good in low field strength areas.

In Teletext field tests (Phase III) conducted in the Los Angeles area, teletext reception was good to excellent for all receiver sites in Grade A contour areas (field strength 68 dBu) and in Grade B contour areas (field strength 47 dBu). The CBS tests were conducted using both the British Ceefax transmissions and the French Antiope system. High quality Teletext pages were produced for all transmission out to the fringe areas around Los Angeles.

The KMOX tests have been conducted partially under the auspices of the Electronic Industries Association in order to provide data whose evaluation, it is hoped, will provide a basis for American technical standards for broadcast VIDEOTEX, that can be proposed to the FCC. Further discussion of the effort may be found in a later section of this report on Standards and Standardization.

PBS Field Trials

The Corporation for Public Broadcasting (CPB) announced a field trial, in mid 1980, of broadcast VIDEOTEX at WETA, Washington, DC, a Public Broadcasting Station (PBS). The Canadian Telidon system was chosen to provide enhanced pictorial and

graphics for this system. The trial has been designed and is to be managed by the Alternate Media Center at New York University School of Arts in conjunction with WETA. Among the information providers for the trial are the Washington Post, the District of Columbia Public Libraries, and a number of Federal agencies including the FTS, the DoE, the Smithsonian Institute, the GSA Consumer Information Center, and a number of others. Suitable broadcast TV terminals will be located in various public locations and in selected private homes for consumer use. As part of the WETA teletext experiment, the National Telecommunications and Information Administration is sponsoring a program which will provide detailed quantification of customer usage, reaction profiles, and requests for information not stored in the initial data base.

Viewtron - The AT&T/Knight-Ridder Miami Trials

In 1979, Knight-Ridder Newspapers (KRN) Inc. announced the formation of a new subsidiary, Viewdata Corp. of America, to administer a pilot test of an interactive VIDEOTEX system to be called Viewtron (Boulder Daily Camera, 1979). Subsequently, AT&T joined Knight-Ridder. A KRN spokesman described the system "... as an adaptation of the British Viewdata (i.e., Prestel) concept to the American market." As in the British system, modified color-home TV receivers will be linked to the data center via the switched telephone network.

The initial pilot project, following more than two years of research by KRN, is being conducted for a six month period beginning in begun early summer of 1980. Approximately 150 to 200 homes in the Miami, Fla. area are being supplied with modified TV receivers for the pilot test. A 6,000 square foot facility in downtown Miami is being readied for occupancy as the first data center and operational headquarters.

The test is being undertaken with the primary goal of assessing consumer response to the information service, which will offer a broad data base including news, weather, sports, product ratings, lists of adult education courses, and schedules of local movies and theaters. The project will also test advertising applications of the computerized information bank.

One feature of the trials will include London to Miami hookups using the Bell International System; all communications, terminals, installation, and management of an information base of ~15000 pages have been prepared for the trials. A special

feature of the VIEWTRON system is the ability to download mosaic graphics to augment local character sets. A demonstration of the VIEWTRON was given by AT&T at the 2nd CCITT Colloquium, in Montreal, June 9-12, 1980.

If Knight-Ritter/AT&T are encouraged by results from this pilot program, they will consider a broader market test program before launching full-scale development of the service, according to the spokesman. An investment of "around \$1.3 million" is planned over the next two years.

Dow Jones/Apple

This service represents a convergence of technologies of the home ("personal") computer and interactive VIDEOTEX systems. Initial announcements were made in July 1979 by Dow Jones and Tocom, Inc. that a field test was operational at a Dallas, Texas suburban location, using an existing CATV system.

User equipment consists of a standard TV receiver, a small Apple home computer, a Tocom microprocessor terminal, and a thermal printing device for hard copy print-out at the user's residence. The subscribers (all business executives in the initial test) can retrieve pertinent financial data on any company of their choice by accessing the central data files of Dow Jones. Data includes latest market information such as current stock quotes. There is no technological reason that the data base be limited in the future to financial information; it may be as varied and as large as user demand warrants.

The user accesses the system by typing the appropriate Dow Jones Retrieval Codes on his terminal keyboard. System routing is by coaxial CATV to a Tocom III-A local data center minicomputer which routes the request via dedicated lines to the Dallas facility of Dow Jones, and via satellite from Dallas to the company's Princeton, NJ, central data base. The desired information is transmitted to the requestor via the same routing.

The Source

"The Source" is the imaginative name of another home ("personal") computer-oriented interactive VIDEOTEX system announced in May 1979 (in the journal Data Communications) by Telecomputing Corp. of America (TCA), a new subsidiary of Digital Broadcasting Corp. (DBC). Subscribers can access the system via their home telephone, but TCA employs the packet switched network of Telenet Communications Corp. for trunk distribution of data.

Subscribers to The Source need an acoustic coupler (with standard RS-232-C interface), a CRT terminal (or a terminal which can be connected to his TV), and a personal computer such as the PET, Apple, or TRS-80.

The service is aimed at the family and student markets and plans, when fully implemented, to offer over 2000 programs, including text editing, income tax preparation packages, and several hundred games. They also will offer airline ticketing service, UPI news wire service, and electronic mail service.

The electronic mail service is considered by TCA to be a key feature of The Source. Three modes of operation are offered:

- (1) "Mailbox": A user transmits a message-at 300 b/s-directly to another subscriber's "mailbox" (terminal storage module). The addressee's terminal prints out "mail call" on his CRT or TV screen. At his convenience, the addressee simply types "mail" on his keyboard and the message is displayed. He can then electronically forward, file, or delete messages.
- (2) "Chat": A subscriber can communicate interactively with another user in real time.
- (3) "Datapost": A customer can send Datapost electronic mail (at an additional cost of \$0.75/message) through TCA to the USPS for next-day delivery. [Datapost is a service, offered by TDX Systems Inc., which receives incoming messages via telephone at its communications center at Chicago's O'Hare International Airport (after having gone through a computer processor, elsewhere) and puts hard copies on evening express mail flights to over 135 U.S. cities for next-day delivery.]

Telecomputing Corp. of America plans to keep subscriber costs low by restricting availability of The Source to off-peak hours: 6 PM to 7 AM on weekdays, around the clock on weekends and some holidays. This is to take advantage of a new off-peak rate called Nightline that Telenet plans to offer to high-volume users. The tariff for this offering was filed with the FCC in April 1979.

Preliminary TCA plans (based upon the off-peak Nightline rates) call for The Source to be priced at \$2.75 per connect hour after a one-time hook-up fee of \$100. The initial fee guarantees a user an account number, a password, and a local toll-free telephone number for network access. At this hourly rate, assuming transmission at 30 characters per second, a monthly cost of \$10 would give the customer up to 72,000 words--or over 400,000 characters--of programming or data base information.

Infocast

Another service, introduced by DBC, Inc. in 1978, is Infocast, an addressable message service using FM radio subcarriers. Based on DBC advertising brochures, the initial service is directed toward business users, offering rental of various types of user terminals including hard copy printers and CRT "electronic mail" stations. Telepoone network transmission is offered as an option to the customer not located within the 20 "high density Infocast areas." Prices quoted by DBC are comparable to services such as Telex and fax.

VIDEOTEX plus Stored Voice

In a presentation before the 1979 International Communications Conference a new service by the Bell System was discussed (Williams et al., ICC, 1979). Called 1A Voice Storage System (1A VSS), this service is intended for use in conjunction with one or more Electronic Switching Systems (ESS). (See Figure 14.) This system could provide mass voice storage and retrieval of messages or announcements upon command from the customer's keypad. An example was offered in which the VSS might be used in conjunction with an interactive VIDEOTEX system (the British Prestel Viewdata System) whereby, in addition to the text (alphanumeric) or graphic information, voice (audio) information could be selected by key access from the user's telephone. The selection process would be from video "menus" listed for the customer's attention. Selection from the menu might take place in a progressive tree process with the final pages selected either in video display mode or in voice, or in both textual form and audio. The development of the Bell mass voice storage system allows for additional flexibility in the expansion of VIDEOTEX systems. All such new services must compete with the already existing newspapers, magazines, TV, radio, and public libraries. Whether these services can grow and create a market in the United States, providing added value at prices that the public is willing to pay, is still an unknown.

Another paper at the ICC'79 (Cornell and Whitehead, 1979) dealt with a number of system architectures for the 1A Voice Storage System (1A VSS). These networks may be highly adaptable to widespread applications of interactive VIDEOTEX. Central to such networks are the No. 1 Electronic Switching Systems (No. 1 ESS) which may provide rapid access and disconnect capabilities for such systems as 1A VSS and, perhaps, VIDEOTEX systems. Shown in Figure 15 are diagrams of 1A VSS Architecture

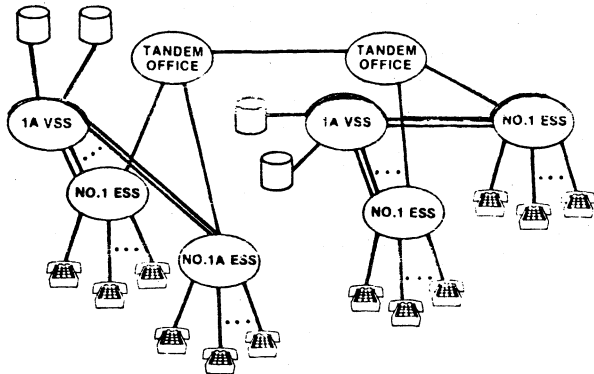

Figure 14. A proposed new mode in the Bell System network.

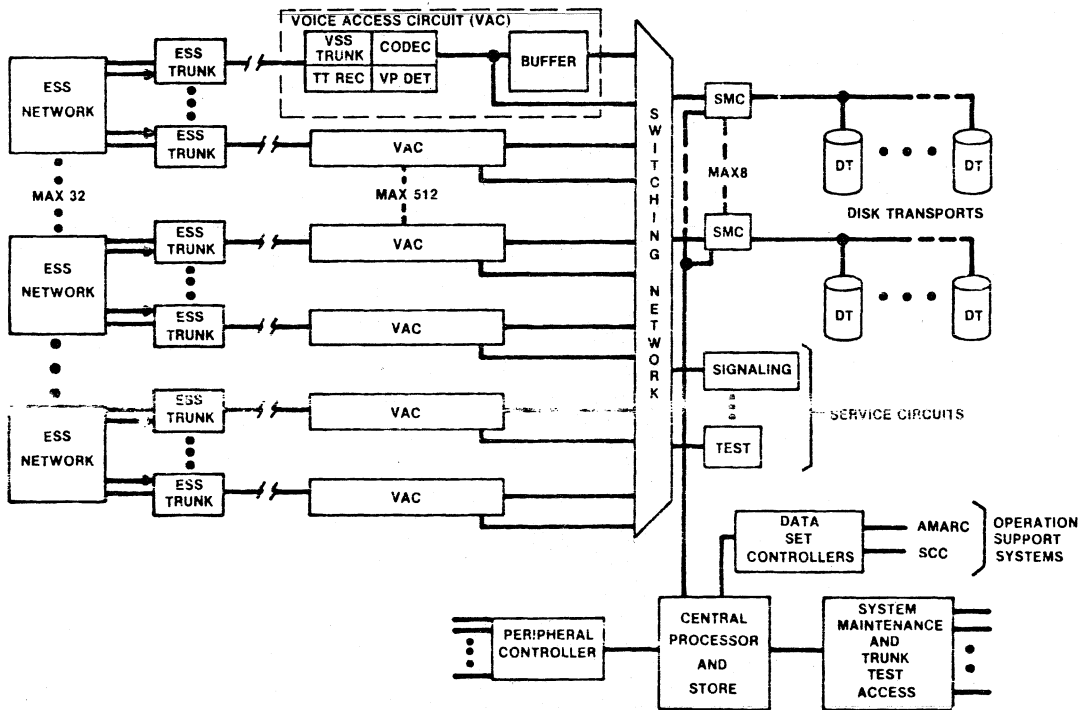

Figure 15. 1A Voice Storage System Architecture.

configurations as presented by Cornell and Whitehead (op.cit.). Replacement of the disk transports and audio nodes by data banks would provide the flexibility, access circuitry, traffic handling, and central functions for widespread VIDEOTEX operations.

One added concern in regard to sophisticated networks such as those that might use the 1A VSS architecture is customer privacy and data information protection. User's input should not be misdirected or, in certain cases, must not be lost. In such systems, protection for the user is obtained through storage of specialized information in the control network of the system.

In the system described by Cornell and Whitehead, the telephone number of the person who may have access to any given message is stored with that message. If the retrieving customer's phone number matches that in the stored address, the message is sent; otherwise it is withheld. Protection against improper retrieval is further insured by storage of a customer access code (Nacon and Worral, 1979). Thus, it would appear that, in addition to the added dimension of voice superimposed on or supplemental to video display via the 1A VSS system, solution could also be found for the problems of privacy and data protection.

2.7. Operational Parameters of Representative Systems

This section presents a discussion, from the potential user's viewpoint, of several fundamental trade-offs among the several operational and proposed types of VIDEOTEX systems. The discussion is based upon the data displayed in Table 6 (additional, supporting data are presented in Table 7a, b), and will follow the format of that table, column by column or by related groupings of columns. The data itemized in Table 6 are derived from the open literature; it is to be emphasized that most of these systems are in early evolutionary (some in conceptual) stages and that many of the quoted values are preliminary estimates and inevitably will change as systems and services mature.

Display Characteristics

The alphanumeric display of VIDEOTEX systems, both broadcast and interactive, is normally limited by the character resolution on the screen of a standard TV receiver. This resolution is based on the number of scan lines per frame and the bandwidth properties of the particular receiver. The European VIDEOTEX systems

Table 6. Operational parameters of representative VIDEOTEX systems.
 Note: Some values are estimated, based on best available data.

SYSTEM			DISPLAY CHARACTERISTICS			INFORMATION AVAILABILITY PARAMETERS			
Generic Type		Representative Examples	I	II	III	IV	V	VI	
Broadcast	Continuously Interactive		Alphanumeric Mode: No. of characters/frame	Graphic Mode: Relative Resolution	No. of Colors Displayed	Time to obtain Request of 1 page Average (Sec.) Spread (Sec.)		Near-Real-Time Data Base Available (No. of pages)	
X		• Ceefax/Oracle • Antiope • PBS-KSL-TV • KMOX-TV•Micro-TV	600 - 1000	Low	4-7	25	10-60	1000	
	X	• Prestel • Titan • Viewtron • GTE/Viewdata • Compucom	600 - 1000	Low	7	2	1-10	10 ⁵ -10 ⁷	
	X	Corporate Insac Viewdata	< 1000 >	Unknown	B&W to 7	2-5	2-20	Large	
	X	Telidon	600 - 1000	Med. to High	7	5	1-12	10 ⁵ -10 ⁷	
	X	Project Ida	600 - 1000	Low to Med.	4 → ∞	2	1-10	Very large	
	X	Green Thumb	512	Low and High	2-7	30	15-50	200	
	X	PLATO	4,800	High	B&W	A few	Max. 16	10 ⁶	
	X	HI-OVIS	Highly Variable	High	4 → ∞	unknown	1-12	Very large	
	X	Captain	120 Kanji	Med.	7	5	1-12	10 ⁵ -10 ⁶	
	X	Dow Jones/Apple	800	Low/Med./High (Variable: Home Computer)	B&W	30	15-50	10 ³ -10 ⁵	
	X	X	THE SOURCE	Detailed information not available; probable similarities to Dow Jones/Apple					
X			Infocast	Unknown	None	None	5	2-10	Large

Table 6 (Continued). Operational parameters of representative VIDEOTEK systems.
 Note: Some values are estimated, based on best available data.

SYSTEM			USER COSTS		TERMINAL INTEROPERABILITY/COMPATIBILITY		COMMUNICATION TRANSMISSION MEDIA		
Generic Type	Representative Examples		VII	VIII	IX	X	XI	XII	
	Broadcast	Continuously Interactive	Initial Terminal Costs (\$)	Recurring Costs (\$)	Among Different Types of Systems	Among Similar Types of Systems	Initial	Other Viable Options	
X			•Ceefax/Oracle •Antiope •PBS•KSL-TV •KMOX-TV•Micro-TV	Mod. (150-300)	Min.	Yes	Some	TV Broadcast	•AM •FM •CATV (coax) •Optical Fiber
	X		•Prestel •Titan •Viewtron •GTE/Viewdata •Compucom	Mod. (200-450)	Low	Yes	Some	Switched Telephone Net	•Downstream •Packet net •AM •FM •CATV (coax) •Optical Fiber
	X		Corporate Insac Viewdata	Med. to High	Med. to High	Maybe	Maybe	Packet Net	All moderate BW duplex media
	X		Telidon	Mod. to High (300-600)	Low to Med.	Maybe	Maybe	Switched Telephone Net.	All moderate BW duplex media
	X		Project Ida	Mod.	Unknown	Maybe	Maybe	Coax	Optical fiber
		X	Green Thumb	Low (100-300)	Low	No	Maybe	Switched Telephone Net	All moderate BW duplex media
	X		PLATO	Very High (8000)	Med.	No	Not in Initial form	Conditioned Telephone ckts.	All moderate/high BW duplex media
	X		HI-OVIS	Mod.	Low	Maybe	Maybe	Optical Fiber	CATV (Coax)
	X		Captain	Mod. to High (300-600)	Low to Med.	Maybe	Maybe	Switched Telephone Net	All moderate BW duplex media
	X		Dow Jones/Apple	Mod. to High (1500-2000)	Low	High	High	CATV/dedicated Tel. ckts./satellite	All moderate/high BW duplex media
	X	X	THE SOURCE	Detailed information not available; probable similarities to Dow Jones/Apple					
X			Infocast	Mod. (< 500)	Low	High	High	FM	Switched tel. net or packet net

Table 7a. System's operator aspects of interactive (duplex) VIDEOTEX systems.

System Name	Sponsor	Status: O: Operational E: Experimental C: Concept	Date in Service	Pages of memory	Downstream Transmission Bit Rate (per sec.)	Coding: A/N Mode Graphics Mode	Format: Char. per Row X No. of Rows
GTE/Viewdata	(U.S.) GTE (under U.K. contract)	E	1980	1	1200	<u>ASCII</u> G	40 x 20
Telidon	(Canada) Dept. of Communications	E	1979	1	1200	<u>ASCII</u> PDI	40 x 20
Green Thumb	(U.S.) DoAg/NOAA	E	1979	4	300	<u>ASCII</u> PDI	32 x 16
Prestel	(U.K.) BPO/Link	E→O	1979/80	1	1200	<u>ASCII equiv.</u> G	40 x 24
Corporate Viewdata	(U.K.) in U.S.: Insac	C→E	1980	1	1200	<u>ASCII equiv.</u> G	40 x 20
Titan	(France) PTT	E→O	1979	1	1200	<u>ASCII equiv.</u> G	40 x 24
Plato	(U.S.) Univ. of IL/ CDC	O	1968	1	1200 and 2400	<u>Unique</u> Unique	80 x 60
Ida	(Canada) Manitoba Tel. System	E→O	1979	1	max. 22×10^3	Not known	
HI-OVIS	(Japan) Government/industry consortium	E→O	E: 1973 O: 1979	1	1200- 9,600	<u>ISO</u> ISO	100 x 40

Table 7b. System's operator aspects of broadcast (simplex) VIDEOTEX systems.

System Name	Sponsor	Status: O: Operational E: Experimental C: Concept	Date in Service	Pages of memory	Downstream Transmission Bit Rate (per sec.)	Coding: A/N Mode Graphics Mode	Format: Char. per Row X No. of Rows
Oracle	(U.K.) IBA	O	1973	4	22×10^3	<u>ASCII equiv.</u> G	40 x 24
Ceefax	(U.K.) BBC	O	1976	4	22×10^3	<u>ASCII equiv.</u> G	40 x 24
Antiope	(France) SOFRA TEV	O	1977	4	22×10^3	<u>ASCII equiv.</u> G	40 x 24
Infotext	(U.S.) Micro TV	E	1979	4	22×10^3	<u>ASCII equiv.</u> G	40 x 20
Teledata	(U.S.) KSL-TV	E	1979	4	22×10^3	<u>ASCII equiv.</u> G	40 x 20
KMOX-TV	(U.S.) CBS/EIA	C→E	1979	4	22×10^3	<u>ASCII equiv.</u> G	40 x 20
Infocast	(U.S.) DBC	C	1979	1	4800 (FM sideband)	<u>ASCII equiv.</u> N/A	80 x 36 (Business Terminal)

have been designed for 40 characters across the screen x 24 rows, or approximately 960 total characters. Some enhancements on very well-focused receivers using the 625-line European scan standard have allowed for a few more characters per row and perhaps a few more rows, suggesting that an upper limit for the European home receiver is approximately 1000 characters.

U.S. and Canadian TV receivers are further limited by a smaller number of raster scan lines (525), permitting a maximum of only 20 rows with a row resolution of approximately 40 characters. This results in 800 total characters for a very well-focused, very high bandwidth receiver. Modern receivers provided with surface acoustic wave comb filters (SAWs) do an excellent job in providing the necessary horizontal resolutions. In the broadcast mode, noise on the signal and other limitations can reduce the useful screen resolution to fewer than this maximum of 40 characters x 20 rows for American VIDEOTEX viewing (as few as 600 total characters).

The character resolution is not to be confused with "dot" resolution -- the ultimate limit of incremental resolution for any given design of TV tube or other CRT. For certain modes of VIDEOTEX operation (such as that of the Telidon system), graphic or pictorial display may yield effective screen resolution 30 to 300 times greater (respectively, for a home receiver or for a high resolution computer terminal) than that possible for the block-mosaic type of graphic display, using character-sized blocks to "draw" a picture, which is used by the Prestel-like systems. The Telidon approach therefore results in geometric or pictorial displays whose resolution is limited only by the receiver characteristics, making the display visually comparable to conventional TV broadcast. This relatively superior Telidon graphic display resolution is achieved by more complex and higher-cost terminal equipment.

Green Thumb, which resembles the Prestel and Titan interactive systems, has an inherent character resolution somewhat lower than any of these foreign systems - even after allowance for the 625/525 scan line compensation. Decisions were made in implementation of the "Green Thumb box" to modulate the decoded data (received on the telephone) directly onto a TV channel subcarrier and to apply this signal directly at the antenna input of the TV receiver. This procedure results in a somewhat reduced bandwidth capability as compared to systems like Prestel where the decoded data bypasses both rf and if circuits of the receiver and is applied directly to the video amplifier. The advantage of this internal modification of

the TV receiver is an increased display bandwidth and therefore higher character resolution accomplished through the bypassing of the rf and IF strips and the direct connection to the video detector output of the receiver. This modification results in higher user terminal equipment costs as compared to Green Thumb, the only system discussed in this report which does not require receiver modification.

At first glance, it would appear that CAPTAIN is a low resolution system as indicated by the relatively few characters displayed on the screen. This is not the case if we remember that the Japanese Kanji characters represent words, not letters in the Western sense, and that the word structure is considerably more complex than that using the Roman alphabet. In the CAPTAIN system, the characters are formed by dot-pattern combinations or by block-graphic combinations. These combinations can serve to meet the Japanese requirements for as many as 3000 Kanji characters in the basic character set. It is claimed by the Japanese that in the future the CAPTAIN system will also be able to handle other countries' VIDEOTEX coding, including the 7-bit coding formats represented by the U.S. ASCII standard and the international ISO codes. Thus, in future CAPTAIN systems, the number of characters displayed may optionally be either 120 Kanji characters or the typical 600-1000 characters/frame using the Roman alphabet.

It may be noted that several of the systems (e.g., Plato and Dow Jones/Apple) offer rather high resolution displays. This higher resolution is almost entirely a function of the cathode ray tube properties of business or computer terminals as opposed to conventional home TV receivers. The PLATO system makes use of an entirely different kind of display screen which has been designed for extremely high detail, both for textual (80 x 60 characters) and graphic modes, presenting an almost square format. The dot resolution of such displays is exceedingly high.

Considering the number of TV's in the U.S. (estimates range upward of 100 million), it may be considered inescapable that both information providers and designers of both broadcast and interactive VIDEOTEX systems oriented toward mass markets will develop coding formats and data bases that are compatible with home receivers. For corporate, educational, or other specialized applications, it is doubtful that the conventional TV receiver will be widely employed as user terminals. The higher resolution (B&W or color) business or computer terminals offer considerably increased resolution per displayed page and a good deal of added flexibility gained from more advanced (and more costly) terminal electronics, including higher capability micro-processors, increased storage, etc.

Color display (see Table 6, Col. III) is an available user option (for both textual and graphic modes) provided by all VIDEOTEX systems except PLATO and a few business services. It has been shown in the U.K. through experience with Ceefax/Oracle and Prestel services that adding color (either to the display background or to the characters themselves) provides emphasis as well as more pleasing displays. This is hardly surprising since the typical TV viewer has become conditioned to color and expects it. The pioneering Ceefax/Oracle systems provided rudimentary color display; more recent, Prestel-like systems offer slightly more flexibility in the number of coding commands allocated to these functions.

All systems, however, are limited to a maximum of 7 colors for VIDEOTEX-type operation as set by the limited coding sets established by the ISO and ASCII standards. (From Table 6 it would appear that HI-OVIS is an exception, but this is in the "conventional" CATV transmission mode only, not code-formatted VIDEOTEX.) These seven colors (the three additive and three subtractive primary colors, plus white) are fully saturated; i.e., tonal gradations are not permitted. To produce the semi-infinite color subtleties corresponding to broadcast TV standards would result in prohibitively costly electronic complexity of terminal coder/decoder circuitry and, for interactive systems, would require either much broader transmission bandwidths or much longer transmission times per frame of information.

Information Availability Parameters

The user of an information system is concerned with (1) ease of use of the system, (2) the size of the data base that can be interrogated, and (3) the speed of access to (and retrieval of) specific data.

A comparison of information availability (see Table A-5a, columns IV, V, and VI) immediately shows a disparity between broadcast VIDEOTEX and interactive VIDEOTEX systems. For broadcast, there may be a few hundred to 1000 pages available; for interactive systems the number of files or pages can be almost limitless. The size of the data base or number of "books" or "magazines" or specific files for the broadcast system is typically limited to a maximum of 100 to 200 pages per broadcast channel. This system involves leafing through a particular "book" before capturing and storing for review the few pages of interest. At four pages per second (probably a maximum for a typical viewer of material), it will take about 25-30 seconds to scan through a 100 page "book," and about twice as long for a 200 page book. In deference to the user, the size of any one file or book is limited

by the user's interest span, the length of time he is willing to wait for specific information to appear, and the time for him to key the page selector for capture/storage and playback during the next display cycle. Specific subjects will probably be carried repetitively during certain time periods on the TV broadcast channels with changes perhaps only every half hour time slot. Thus for an arbitrary number of channels as, for example, five channels with overlapping half-hour slots, not much more than 1000 pages can be made available to the user from among five TV stations.

By comparison, interactive VIDEOTEX systems will permit interrogation of any publicly available data as quickly as connections can be made and the file searched out by the computer. A few key commands permit a review of hundreds of thousands of pages from a huge library of stored data (system operators speak of files up to 100 million pages for mature systems). This ready access to such large files represents a major advantage of interactive systems. It should also be unnecessary to review a great deal of unwanted material to focus on the specific area of interest. It is to be noted, as shown in column V and VI of Table A-5a, that the waiting time for access to pages of information is reasonably short for all information systems with the exception perhaps of broadcast VIDEOTEX.

Of special note is that with the PLATO system one can also interrogate highly complex data in a truly interactive mode. Specific answers may require hunting by the computer through very complex files, but the large, fast computers and relatively fast data streams (2400 baud) make even such complex interactive systems tolerably fast, permitting access times of a few seconds to a maximum of a few tens of seconds.

User Costs

The matrix of user parameters versus systems, Figure 6, columns VII and VIII, permits a qualitative comparison of initial and recurring costs among a number of individual and generic VIDEOTEX systems. As noted, estimated initial costs of modified home TV receivers for basic VIDEOTEX services or for specialized terminals designed for more sophisticated systems may range from under \$200 to as much as \$8000-\$10,000. As the result of the relatively recent application of micro-processor and display technologies to VIDEOTEX, absolute hardware costs are difficult to assess at this time. The minimum estimated costs of Table 6 for modified home receivers may well be achieved when production volume reaches the 100's of

thousands of units; however, for at least the next few years, it is likely that the costs for home equipment may be closer to the upper ranges appearing in Table 6 under columns VII and VIII for these basic VIDEOTEX systems.

Among the more sophisticated VIDEOTEX systems, Telidon and CAPTAIN will probably cost considerably more than conventional system such as Prestel or Titan due to the greater complexity of circuitry and the additional microprocessing components and large memory storage needed for such systems. This penalty in price can make the adoption of Telidon slower for people not willing to pay the premium price of initial installation.

The still more sophisticated business-like terminals may range in price from \$1000 to \$10,000. These higher priced systems are not expected to compete in the residential mass markets and will most likely be used for intracompany information and control applications, educational, medical, or financial applications, etc.

Monthly or annual costs may prove negligible for broadcast VIDEOTEX. Since TV receivers in the U.S. are not licensed, the only monthly or period costs for such systems may be the leasing or renting of such equipments, since there is not expected to be a charge for use.

For interactive systems, however, the methods of establishing tariffs or pricing for page access, telephone connect time, and other period or non-recurring costs will depend on discussion among the purveyors of information (IP's), the advertisers, the data processing organizations, the switching and network operators, the FCC, and finally the customer or user. Since there is yet no experience in the States with regard to size of markets or fees, the recurring costs as indicated in Column VIII of Table 6 is an approximation or estimate of how much computer time is involved. No other pricing can be established at this time. One set of approximate charges has been offered by Insac (Viewdata). (See Section 2.6.)

Terminal Interoperability and Compatibility

The rapid growth in Europe and Japan of both broadcast and interactive VIDEOTEX systems has created problems of compatibility and interoperability. Earlier attention to standard formats and protocols may have alleviated some of the problems now facing developers of these systems. On the other hand, premature "freezing" of standards (in particular, of character data sets) might have impeded or prevented significant advances in graphic resolution, such as those evidenced in the Canadian Telidon and the Japanese CAPTAIN systems.

In Section 3 we discuss the problems of systems and software standards, including interoperability among somewhat differing kinds of information systems. Also discussed are the needs for standards for interconnectability of common user terminals for both broadcast and interactive systems. In Table 6, columns IX and X, estimates are given for terminal interoperability once standards have been established for queuing, character representation, screen formats, and keyboard protocols. As standards are adopted and systems manufacturers conform (at least for home systems), conventional broadcast and interactive systems may be expected to evidence a high degree of interconnectability or interoperability. International standards study groups have intensified their efforts in considering standards for character code and hand-off protocols to provide for such interoperability.

The Programmed Logic for Automated Teaching Operations has been operational for a number of years. The original purpose of the system was to provide a highly interactive computerized teaching system. Networks have generally been dedicated, and little need was shown for transactions or interconnectability with other systems. Since PLATO is now becoming a more universal information system, the need for interoperability with other VIDEOTEX systems may become desirable.

The Green Thumb prototype system is not compatible with different systems only because no internal modifications are presently incorporated into the TV receiver (a cost reduction factor). The Green Thumb home terminal could be made fully compatible with other broadcast or interactive systems by the necessary modifications within the receiver.

Communication Transmission Media

Present broadcast VIDEOTEX services have been built around a cooperative effort between TV broadcasters and the system operators. Thus, Ceefax/Oracle and similar, proposed U.S. systems such as those used by KSL-TV, KMOX-TV, and Micro-TV will all use a portion of the vertical blanking interval of the composite broadcast video signal to transmit data. Part of the reason for use of this method of transmission may be historical (somebody did it first) and part convenience, since the home TV receiver is readily accessible for visual display of the data and most consumers are accustomed to the broadcast mode reception of television. It is to be noted, however, that for future systems other transmission options may be perfectly acceptable for simplex operation. Radio (AM or FM) and CATV are all acceptable technical alternatives.

For interactive networks, with few exceptions, the switched telephone network has been used to provide both upstream and downstream communication. Alternatives for the future may include use of the telephone to request the information and any of a number of available transmission media to provide high data rate transmission back to the user. Thus, options may be telephone upstream and alternatives such as packet transmission, FM, CATV (coax), or optical fiber transmission to the user terminal. Systems such as GTE/Viewdata, Compucom, and Prestel may all be subject to such transmission options. At least one system (Insac's Corporate Viewdata) is being developed around a private, packet-switched data network. Project Ida and HI-OVIS are both highly dependent on broadband coax or optical fiber between the data/computer centers and the user.

Options presently are limited by the transmission choices into the home. The telephone reaches virtually all of the U.S. population. Television transmission, either through the air or by cable, is available to most homes, as is AM and, to a lesser degree, FM radio. Other technologically viable options may not be easily implemented for a variety of reasons, economic as well as regulatory.

2.7.1. Comparison of Various Generic Systems Summarized

- . Broadcast VIDEOTEX systems are the least expensive, from the user viewpoint, in terms of both initial and recurring costs. Costs for the operators are high, particularly for the equipment added at broadcast transmitters, but not nearly as costly as interactive data distribution networks.
- . For broadcast services, the menu offered to the user is limited by practical considerations such as time to obtain request of a page.
- . The subject matter and detail offered to the consumer by broadcast service is completely at the discretion of the information provider or system operator.
- . Interactive systems offer the same minimum display qualities as broadcast VIDEOTEX systems; superior resolution may be offered by sophisticated systems.
- . Perhaps the two most notable advantages of the interactive services are (1) the virtually unlimited data base and (2) the ability to rapidly access a given subject to whatever detail desired.

- . Initial user terminal equipment costs for interactive systems are moderately high. Unlike broadcast services, there will probably be a per frame ("page") charge and, in some service areas, an additional cost for the use of the telephone or other communication link. Such costs can be significant for the frequent use of such services.
- . Business-oriented services such as Insac's Corporate Viewdata appear to be in a class by themselves. Initial costs for the user may be quite high. However, for intrabuilding or interoffice services, basic costs may be rapidly amortized by virtually continuous operation. It is not unlikely that such data systems will be operated through leased, dedicated lines tied directly to computer ports and multiple user terminals. Charges for such systems could very well be on a monthly, leased basis rather than on a page basis.

3. STANDARDS AND STANDARDIZATION

Standards in the telecommunications field have never been straightforward, particularly in an environment involving rapidly evolving new services and markets, and the rapid changes in technologies to support the systems and services for these new markets. An example of such rapid expansion has been the new information services such as telex, fast public facsimile, Videotex, and Teletex.

The international communities, through the help of CCITT and other international standards groups, have sought to accommodate the wide range of services through the design of networks to accommodate such services. It would be desirable to have common standards for protocols and screen formats. However the independent development and internal adoption of Videotex systems simultaneously by various national groups have made difficult the adoption of common standards for such information systems as the British Ceefax (broadcast Videotex) and the French Antiope. Instead, through the effort of CCITT Study Group VIII, compatibility is to be effected for the French and British systems via the data networks. Although this implies a greater burden on the network interfaces, it does suggest that information services with incompatible systems can be interconnected directly with suitable network interfaces, and such systems should be capable of providing customer services without loss of acceptable quality for the user.

In the U.S. there are a number of field trials, now in operation or planned for the near future, planned to measure the technical effectiveness of a number of Videotex systems, in particular the French Antiope, British Ceefax, and Canadian

Telidon. Most such trials have been or will be via the TV broadcast media. As was noted earlier in section 2.6, among the more aggressive engineering tests of broadcast Videotex have been those conducted by CBS-owned KMOX-TV St. Louis (1979-1980). On the basis of their conclusions, CBS has announced their recommendations to the FCC for a broadcast teletext system in the United States, a modification of the French ANTIOPE system, to allow for compatibility with the U.S. 525 line TV standard. The contention by CBS is that the public will best be served by early adoption of FCC rules and standards for broadcast teletext. Zenith and RCA as well as a number of other U.S. set manufacturers and suppliers of services (such as Home Box Office, HBO) are not at all in agreement with CBS as to their recommendations for a standard for early adoption.

It is the contention of the latter group that a modification of the British Prestel/Ceefax system (in extensive service throughout the United Kingdom) be adopted by U.S. manufacturers and systems operators. Their recommendations have been offered for approval by the EIA Broadcast Television System (BTS) Teletext Subcommittee. It is to be noted that neither the French ANTIOPE system nor the British CEEFAX system is directly compatible with the Canadian Telidon system, an advanced Videotex system providing options of broadcast or interactive mode of operation. It is the latter system which has been adopted for trials to be conducted by PBS station WETA in Washington, DC, starting in late 1980. The WETA experiment will be the first use of Telidon in a broadcast mode. Thus for the U.S. there are many system offerings, each with their own virtues: receiver simplicity and slightly lower costs for the British system; greater flexibility and more rapid page access for the French Antiope system; higher costs (and higher-resolution graphics at still greater TV decoder and receiver costs) for the Canadian Telidon System. To add to the dilemma, Canada, as our next door neighbor is strongly committed to the Telidon system, which they claim can be readily made interoperable with the French Antiope system, but less so with the British Ceefax system.

Station KSL-TV, Salt Lake is planning a broadcast Videotex service which will not be put on the air for the general public for some time in the future in order to maintain conditions for this study as a controlled experiment. Decoder boxes and modified TV receivers are available only to participants, chosen by KSL-TV, who can contribute feedback relating to technical properties, user data informational demands, marketing and advertiser inputs, and other questions relating to operational characteristics unique to this sampling of participants.

3.1. Compatible Standards for Broadcast and Interactive Systems

As has been noted elsewhere in this report, broadcast and interactive systems have a considerable number of system elements in common. Functional components at the user end that are quite similar include the keypad entry and control-function microprocessor, the page storage memory units, display generator (stroke generator), and the TV display terminal. (The keypad and control-function microprocessor accept the incoming signals and store them in the memory for immediate or later display on the viewing screen.)

These functional components determine the blocks of data to be captured for storage, queuing, and processing for display. These functions are built into the decoder elements, and do not differ widely in principal among broadcast and interactive systems,

The major obvious differences between the unidirectional (broadcast) systems and bidirectional (interactive) or customer response systems are in the methods used for transmission of data and for feedback to the data center for specific requests. Unidirectional systems generally use the TV broadcast channel to carry the information on an unused portion of the video signal; one-way CATV cable systems could readily carry such information. Bidirectional services, on the other hand, require essentially that a point-to-point connection be made between user and the data service or computer center.

Although most publicized TV broadcast systems in Europe and North America have chosen the TV vertical blanking interval for insertion and subsequent transmission of the video data, other broadcast modes might also work out as being equally effective. Private data network transmission links or FM/AM radio would, in principle, be equally effective. The video subcarrier was chosen as the means for Teletext-type broadcasts as a systems convenience, since such information systems have been developed about the home TV receiver as the display terminal. Since the home TV receiver is already available as a display terminal, it has been found convenient to add a relatively small amount of electronics to the receiver and to transmit and extract the VIDEOTEX data from a small portion of the transmitted television signal. As several transmission options appear viable, it may be too early to establish rigorous standards in the areas of transmission and transmission protocol. The previously discussed CBS/EIA tests may constitute a significant step in removing this concern from the area of speculation.

3.2. Display Formats and Character Sets

Display formats and character sets relate to alphanumerics (letters, numbers, and symbols) and to the quality of graphics (pictorial information). What is displayed is dependent in part upon the built-in display generator, which provides a given set of characters to be displayed on the screen on the basis of some agreed upon ASCII or ISO code. Instruction standards for line or word spacing, end of line, end of page, or end of data input are necessary as part of formatting of a page display. This will be particularly important in international VIDEOTEK. There is as yet no internationally agreed upon standard code sets for different countries and none is foreseen before the end of 1980. Study Group VIII of the CCITT is at present debating the merits of differing character sets. The ASCII set commonly used here in the U.S. may not be acceptable among other Administrations. Presently, the British Prestel uses a modification of the ISO 2022, an international reference version for use in Europe.

The following figures illustrate the problems with display formats or character representations. The present British Teletext system uses the slightly modified ISO 2022 character set which closely resembles the U.S. ASCII code. The Teletext character set is illustrated in Table 8, showing 8 columns and 16 rows for a total of 128 characters or command codes. The 0 and 1 columns are known as the "C0" set and provide for command or control keys. The columns 2 through 7 are the "G0" set to provide, in normal operation, the Roman alphabet. To provide for color or graphic mode representation, columns 4 and 5 may also be shifted by command into a so-called "C1" set, as illustrated in Table 9.

The British Teletext system was not designed to provide for a broader based alphabet than necessary for representation of English language text plus some simple graphics and color. Other languages (e.g., French, Dutch, Scandinavian, and German) contain a number of accented vowels, combinations of letters or special symbols which are unique and necessary for the presentation of text in that respective language. One attempt at flexibility is a CCITT Study Groups I and VIII contribution by the Federal Republic of Germany. This contribution addresses the problem of widely varying alphabets among nations. In Belgium, for example, in addition to the normal Roman alphabet, there are 26 special letters. Also, for all nations, it is necessary to provide for a universal set of characters including mathematical symbols and other internationally agreed upon symbols and constants (See Table 4). The CCITT recommendation was basically to maintain compatibility with the UK Teletext service already in operation, and by simple key command to

					b7	0	0	0	0	1	1	1	1
					b6	0	0	1	1	0	0	1	1
					b5	0	1	0	1	0	1	0	1
					col	0	1	2	3	4	5	6	7
b4	b3	b2	b1	row									
0	0	0	0	0			SP	0	@	P	—	p	
0	0	0	1	1			!	1	A	Q	a	q	
0	0	1	0	2			"	2	B	R	b	r	
0	0	1	1	3			£	3	C	S	c	s	
0	1	0	0	4			#	4	D	T	d	t	
0	1	0	1	5			%	5	E	U	e	u	
0	1	1	0	6			&	6	F	V	f	v	
0	1	1	1	7			'	7	G	W	g	w	
1	0	0	0	8			(8	H	X	h	x	
1	0	0	1	9)	9	I	Y	i	y	
1	0	1	0	10			*	:	J	Z	j	z	
1	0	1	1	11			+	;	K	←	k	⌘	
1	1	0	0	12			,	<	L	½	l		
1	1	0	1	13			-	=	M	→	m	⌘	
1	1	1	0	14			.	>	N	↑	n	÷	
1	1	1	1	15			/	?	O	⊠	o	DEL	

Table 8. Modified ISO 2022 alphanumeric character set used in U.K. Ceefax/Oracle broadcast systems. (Source: CCITT Com I-125-E, Com VIII-93-E.)

4	5
ALPHA BLACK	GRAPHICS BLACK
ALPHA RED	GRAPHICS RED
ALPHA GREEN	GRAPHICS GREEN
ALPHA YELLOW	GRAPHICS YELLOW
ALPHA BLUE	GRAPHICS BLUE
ALPHA MAGENTA	GRAPHICS MAGENTA
ALPHA CYAN	GRAPHICS CYAN
ALPHA WHITE	GRAPHICS WHITE
FLASHING	CONCEAL DISPLAY
STEADY	CONTIGUOUS GRAPHICS
END BOX	SEPARATED GRAPHICS
START BOX	ESC
NORMAL HEIGHT	BLACK BACKGROUND
DOUBLE HEIGHTS	NEW BACKGROUND
SO	HOLD GRAPHICS
SI	RELEASE GRAPHICS

Table 9. "C1" character set for color and graphic display.
(Source: CCITT, COM I-152-E; COM VIII-93-E).

allow switching over to a specific nation's character code set and to the universal mathematical notation code sets. Examples from among several of these character sets are shown in Tables 10, 11, and 12.

Implementation of multicharacter sets for as many as sixteen different languages would appear rather formidable and costly of memory. However, as illustrated by Tables 10 and 11, it can be seen that a large number of characters, including the Roman alphabet and numerics, are repeated in each character set. Thus 64 characters need be stored only once, and a number of special characters do have some redundancy with each other. The memory requirements and therefore the overall costs, according to the sponsors for such a standard, may not be as formidable as at first appears. Other countries, particularly the Netherlands (Study Group Contribution No. 132, June 1979), have made similar recommendations.

Neither of these proposed standards takes into account the alpha-geometric models or the alpha-photographic models recommended by the Canadians. The Canadian coding schemes are suggested in CCITT Study Group VIII Contribution No. 129, June, 1979.

Coding schemes according to the Canadian entry would include:

a) Alpha-mosaic model

A text communication source which comprises alphanumeric coded texts and mosaic-coded pictorial images (block-graphics).

b) Alpha-geometric model

A text communication service model which comprises alphanumeric coded text and geometrically coded pictorial images.

c) Alpha-photographic model

A text communication source model which may provide alphanumeric coded text and pictorial images including ideographic characters described by dot-by-dot matrix representation.

For the Canadian proposal, the basic levels of VIDEOTEX would be rather similar to those offered by other systems. However, the extended levels of VIDEOTEX would require pictorial coding and display capabilities. Capabilities for display would then include (1) mosaic, in which the graphics would be displayed as combinations of block graphics; (2) geometric, in which geometric picture-forming instructions would provide pictures formed by elements of lines, curves, and dots to provide images; and (3) photographic, where pictures would be displayed by point-to-point or run-length encoded representation.

					b ₇	0	0	0	0	1	1	1	1
					b ₆	0	0	1	1	0	0	1	1
					b ₅	0	1	0	1	0	1	0	1
						0	1	2	3	4	5	6	7
b ₄	b ₃	b ₂	b ₁										
0	0	0	0	0			SP	0	.		,	£	
0	0	0	1	1				1	£		×	∫	
0	0	1	0	2				2	\$	—	β	{	
0	0	1	1	3			#	3	f	—	γ	}	
0	1	0	0	4			□	4	¥	—	Δ	Σ	
0	1	0	1	5			%	5	¢	↑	π	√	
0	1	1	0	6			&	6	⊙	↓	φ	∫	
0	1	1	1	7			§	7	⊙	→	ω	∞	
1	0	0	0	8			∂	8	⊙	←	Ω	∞	
1	0	0	1	9			á	9	∂	⇒	.	÷	
1	0	1	0	10			*	†		≈	‰	∞	
1	0	1	1	11			+	±	.	(¼	"	
1	1	0	0	12			°	<	«	'	½	!	
1	1	0	1	13			²	=	≠)	¾	?	
1	1	1	0	14			³	>	»	:	~	—	
1	1	1	1	15			/	μ	\	;	□	DEL	

Table 10. Character set for mathematical and other special symbols.
 (Source: CCITT Com I-125-E, Com VIII-93-E.)

b ₇	0	0	0	0	1	1	1	1				
b ₆	0	0	1	1	0	0	1	1				
b ₅	0	1	0	1	0	1	0	1				
	0	1	2	3	4	5	6	7				
b ₄	b ₃	b ₂	b ₁									
0	0	0	0	0			SP	À	.	P	,	p
0	0	0	1	1			Å	ä	A	Q	a	q
0	0	1	0	2			Ä	ä	B	R	b	r
0	0	1	1	3			Æ	æ	C	S	c	s
0	1	0	0	4			Ð	ð	D	T	d	t
0	1	0	1	5			É	é	E	U	e	u
0	1	1	0	6			Ë	ë	F	V	f	v
0	1	1	1	7			IJ	ij	G	W	g	w
1	0	0	0	8			Ó	ó	H	X	h	x
1	0	0	1	9			Ö	ö	I	Y	i	y
1	0	1	0	10			Ø	ø	J	Z	j	z
1	0	1	1	11			ß	ß	K	(k	"
1	1	0	0	12			Ü	ü	L	'	l	!
1	1	0	1	13			°	°	M)	m	?
1	1	1	0	14			3	2	N	:	n	-
1	1	1	1	15			/	μ	O	;	O	DEL

Table 11. Modified character set for Northern European and German Languages.
 (Source: CCITT Com I-125-E, Com VIII-93-E.)

				b ₇	0	0	0	1	1	1	1	
				b ₆	0	0	1	1	0	0	1	1
				b ₅	0	1	0	1	0	1	0	1
					0	1	2	3	4	5	6	7
b ₄	b ₃	b ₂	b ₁									
0	0	0	0	0			SP	°	.	P	,	p
0	0	0	1	1			À	à	A	Q	a	q
0	0	1	0	2			Â	â	B	R	b	r
0	0	1	1	3			È	è	C	S	c	s
0	1	0	0	4			É	é	D	T	d	t
0	1	0	1	5			Ê	ê	E	U	e	u
0	1	1	0	6			Ë	ë	F	V	f	v
0	1	1	1	7			Î	î	G	W	g	w
1	0	0	0	8			Ï	ï	H	X	h	x
1	0	0	1	9			Ô	ô	I	Y	i	y
1	0	1	0	10			Œ	œ	J	Z	j	z
1	0	1	1	11			Ù	ù	K	(k	"
1	1	0	0	12			Û	û	L	'	l	!
1	1	0	1	13			Ç	ç	M)	m	?
1	1	1	0	14			3	2	N	:	n	-
1	1	1	1	15			/	∞	O	;	o	DEL

Table 12. Modified character set for special characters.
 (Source: CCITT Com I-125-E, Com VIII-93-E.)

The Canadian proposed standards for character and pictorial representations, like proposed standards from Japan, are a departure from the less complex character sets suggested by many governments. These questions are in the process of debate. It is likely that there will be more than one standard adopted.

Implications for the U.S. are that, if such multi-reference codes are widely adopted for use in Europe, we may either have to accept the European reference codes and revise any existing U.S. character generators, or go it our own way. The latter might affect international VIDEOTEX broadcasts, and impose limitations on ease of exchange of software packages and sharing of information between European and American broadcast or interactive services. This may not be serious if the potential advantages for the U.S. are the development of a system which receives good market acceptance by the U.S. public.

3.3 Standards for the Commercial TV Receiver as a Terminal

The commercial home television receiver, whether black-and-white or color, does not approach the character-resolution capabilities of the computer terminal. Requirements are for a fairly high brightness on the home TV screen, assuming a normal ambient room illumination. For the case of shadow mask color television receivers, this requirement, coupled with the necessity for the electron beam to illuminate several phosphor dots simultaneously, has caused the television receiver designer to compromise between brightness, color rendition, and contrast ratio qualities of the receiver. As a result, definition or resolution is less than would be maximally desirable for text or character display. This lower resolution capability of commercial TV receivers, together with limitations imposed upon the memory store in the decoder boxes (an economic compromise reflecting current technical state of the art), has placed restrictions on the maximum number of characters that can be displayed horizontally along the face of the picture tube. Also, the number of rows that can be displayed is limited by the picture tube scanning systems and the number of lines that can be displayed. European systems provide 625 scanning lines as compared to the U.S. 525 lines (of which only 425 to 450 are actually visible on the screen). The differing international TV standards, the technical reasons for limiting resolutions, and the question of readability

have led to several versions of character format as, for example, shown in the table below:

Ceefax	40 x 24	GTE/Viewdata	40 x 20
Prestel	40 x 24	KSL-Infocast	32 x 20
Infotext	40 x 20	Green Thumb	32 x 16.

Activity in CCITT Study Groups I and VIII have intensified as field trials in Europe, Canada, and the U.S. have been instituted. Notably, the Prestel Service market trials were begun in September 1978, with 1500 users served by a single computer center using a number of dedicated GEC 4080 computers. Each of the computers can handle 100 ports. The Prestel (interactive) services have been designed so that TV receivers modified for Prestel services will also be fully compatible with Ceefax (broadcast) services, indicating some attempt at system standardization in the United Kingdom.

3.4 International Standards Objectives

It has been recognized by CCITT and the International Standards Organization (ISO) that an ongoing and effective dialog should be developed among the various national administrations within the respective frameworks of the CCITT and ISO. The purpose of these discussions would be to clearly and comprehensively identify the important parameters of VIDEOTEX services to establish which among these many parameters should be subject to standardization. There is general agreement among the various participants that the 1979/1980 time frame is not too early to start drafting standards covering systems scheduled for trials in the early 1980's.

Principal issues, as discussed in Section 3.2, generally have related to coding formats and character descriptions to resolve the differences among a large number of systems currently operating or in experimental stages in France, the U.K., Canada, and Japan. Many of the issues have been discussed through contribution from various interested parties, particularly in CCITT Study Group VIII, at first almost entirely from non-US national organizations. More recently there has also been a number of contributions from the U.S., primarily from AT&T. In the AT&T contribution to Study Group VIII (Com. VIII No. 130-E), VIDEOTEX Standards Issues are covered in some detail. This is a first step in developing a draft plan for a so-called "s" series of recommendations, but would describe the minimum characteristics for a VIDEOTEX terminal capable of accessing international VIDEOTEX services. Resolution of the various technical issues will be taken up in the CCITT Plenary Assembly, November 1980.

Quite independent of the efforts of various study groups within CCITT have been the contributions from the International Standards Organization (ISO), which are reproduced as part of the contribution series (#139-140) of CCITT Study Group VIII. (These two contributions are reproduced as appendices to this report.) The Organization's documents TC97/5C2, N984, and N985 contain Part I and Part II of a proposed International Standard entitled "Coded Character Set for Text Communication." The draft standard, when complete, will be divided as indicated below:

- Part I General Introduction,
- Part II Roman alphabetic and non-alphabetic graphic characters,
- Part III Control Functions.

It is not as yet certain which "standard" will be adopted; i.e., that of ISO or the CCITT. There is close resemblance of objectives between the ISO draft standard submission and that of CCITT. To make sure of proper liaison between Study Group VIII (CCITT) and the equivalents in CCIR and ISO, coordination has been established among the many working parties of the respective groups. General agreement concerning the categories for standards are listed below:

- . Display characteristics
 - formats on screen (rows x lines)
 - inputs to the screen - internal/external
 - character formation
 - color drive considerations
- . Character repertoire
 - symbol sets
 - flexibility of symbol set interchangeability
 - programs for creating images
 - animated motion by control of certain drive parameters
- . Flexible transmission coding format
- . Line control
 - modems
 - protocols
- . End-to-end procedures and protocols
 - identification/passwords/privacy
 - compatible access to other VIDEOTEX systems
 - costing and billing procedure.

This report has reproduced portions of CCITT Study Group I documents in Appendices I and II: The first is contribution no. 176 (source, United States of America): "Videotex Terminology; Parameters Subject to Standardization (June 20, 1979)." The second document is Contribution no. 178 (source, American Telephone and Telegraph Co.) entitled "Summary of VIDEOTEX Standards Issues (June 20, 1979)."

Both documents refer in some detail to the categories of parameters and services mentioned in the forgoing outline. Contribution no. 176 urges that standards for display characteristics allow for maximum flexibility of graphic and symbol display. This would call for the smallest possible picture elements for high resolution graphics. Free-form oriented graphics would allow for individually addressable picture elements, permitting maximum possible picture resolution in pictorial representation. The AT&T document states that "...CCITT Recommendations (for Standards) should not be limited to what is currently economically feasible, but should be drafted with enough flexibility to permit future enhancement to the service as the capabilities of the technology evolve..."

3.5 Summary of Coding Compatibility and International Standards

International adoption of a common character coding standard faces difficulties from the onset, largely because of considerable differences among coding schemes of the several existing and proposed VIDEOTEX systems. The United Kingdom, for example, derived its Prestel coding system from experience with the Teletext broadcast service. This coding provides for versatile manipulation of display, especially in color parameters, but at the expense of allocating many code characters for these command and control functions, leaving a minimum of codes for symbols. These latter are adequate for the written English language, but pose problems in displaying nuances (such as vowel accents) of some European languages.

A more adaptable system has been proposed by a number of European countries. It is considered to be an "open coding" system, closely resembling that of the international Teletex service. (Not to be confused with the British Teletext, Teletext is an operational service intended for international exchange of business correspondence -- more resembling international electronic mail than VIDEOTEX services.) The point to be made is that, in development of the Teletext code, flexibility was mandated in order to accommodate several written languages. The Canadian interactive Telidon system is compatible with this proposed European coding, and has the additional characteristics of greatly enhanced detail for pictorial and graphic display.

Additional international compatibility problems exist for U.S. and Canadian systems (in terms of TV receiver framing, raster generation, and protocols) as the result of the North American 525 line scan/60 Hz standard vs the European 625 line/50 Hz standard. The Japanese CAPTAIN system constitutes a third case: a sort of hybrid design in which combinations of protocol and control codes are transmitted along with a matrix bit stream acceptable to any TV receiver. This system introduces additional complications in terms of software interchangeability with other countries.

A standard must be arrived at to define VIDEOTEX as an information and telecommunications service that provides users or subscribers with visually displayed information, augmented by audio information. There is growing opinion within the CCITT Study Groups that greater effectiveness would result in transmission of information if VIDEOTEX terminals would alternate between voice and data during the same calling period. Greater emphasis on audio would have marked effect on protocols for distinguishing between data and voice input. There would also be the need for proper routing of messages over the appropriate transmission medium.

Another objective is to define VIDEOTEX services more broadly to permit a wide variety of services for both business and home customers.

4. NETWORKING ASPECTS OF INTERACTIVE VIDEOTEX SYSTEMS

Described elsewhere in this report are various kinds of systems which in their logical extension of services could provide widely used national or international computer-based information networks. Information would become as widely accessible as the nearest telephone when it is combined with some form of affordable (leased or purchased) alphanumeric or graphic terminal to provide visual (and audio?) presentation of a large variety of topics or services.

It is to be assumed that the terminals in such a network will be interconnected to provide one or more of the following capabilities:

- . communication with a larger variety and perhaps a large number of data centers,
- . access to other user terminals (in more sophisticated systems),
- . access to computational capabilities within the network,
- . delivery to the home or office terminal of selective software programs to permit off-line computational services (financial or other business transactions),
- . potential (in sophisticated business or home applications) for data entry or updating as well as retrieval.

4.1. System Architecture

It is to be assumed that no interconnect changes will be required in establishing a customer's interactive VIDEOTEX service via the telephone switched network other than the requirements for an authorized (certified) interface e.g., the proper modems, in his home or office. Networking will require that the customer's access to the system will be through a conventional or automatic dial-up feature to the data center supplying his community or area. This connection will be made via the local loop access into the switched network or local exchange. The choice of how the VIDEOTEX system provides access to local VIDEOTEX centers for regional or national distribution, either through star, ring, or mesh configurations, is a matter of how the system will best function with maximum economy of equipment and maximum utility for the user, while at the same time minimizing the over-loading of exchanges and local data nodes without requiring high data-rate lines. Network switching and loading are discussed in some detail in Section 5.

The star configuration shown in Figure 16 allows for a major or national central computer and its associated data storage bank, with the radial arms connected to regional data centers and hence to the public telephone system and home terminals through local telephone switching centers. This network configuration was originally suggested for the British Prestel service, but was abandoned in favor of ring and mesh interconnects, also as shown in Figure 16. The mesh network allows for direct transfer of information between regional data centers and for direct input or update of information at any regional node for distribution to some or all other regional nodes. Similarly, local centers may also be interconnected in ring or mesh configurations. Choice among the many network approaches involves a number of factors:

- (1) determination of probability of continuation of service, even in the presence of line or equipment failure at some nodes;
- (2) number of ports required to reduce probability of blocking (discussed in Section 5);
- (3) flexibility of entry of data for local, regional, or national distribution; and
- (4) provisions for system and subscriber growth.

Network configuration favored by the Federal Republic of Germany involves a packet-switched network for data distribution to regional data centers

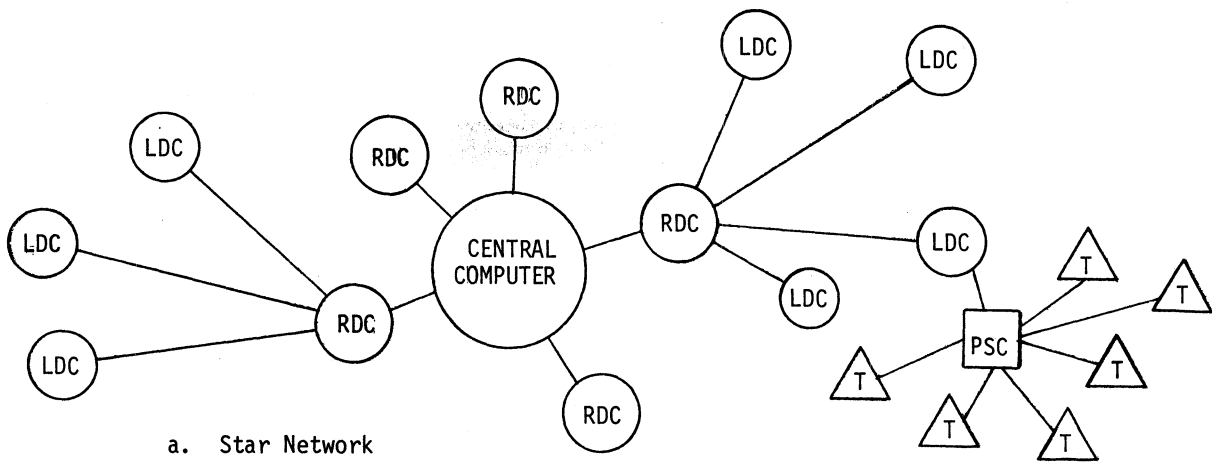

a. Star Network

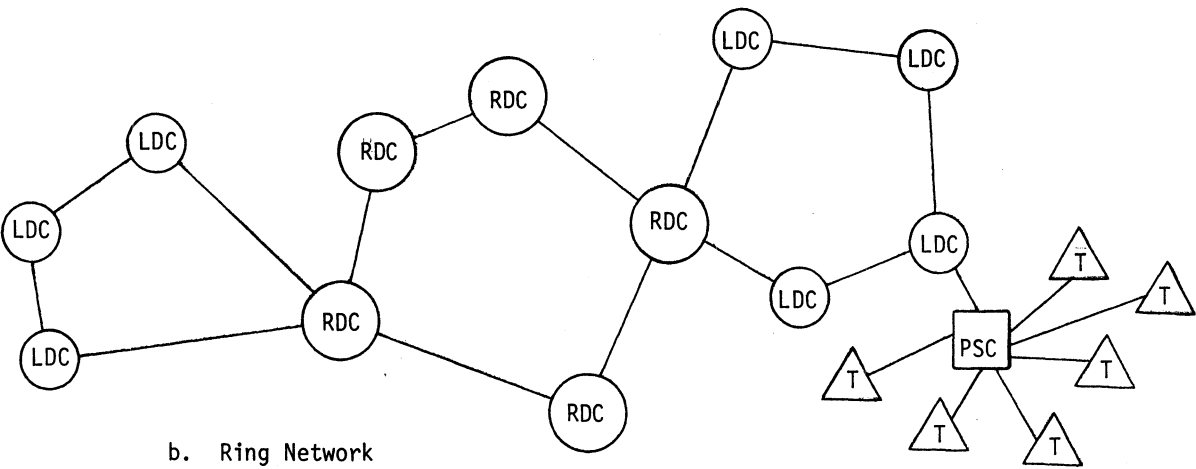

b. Ring Network

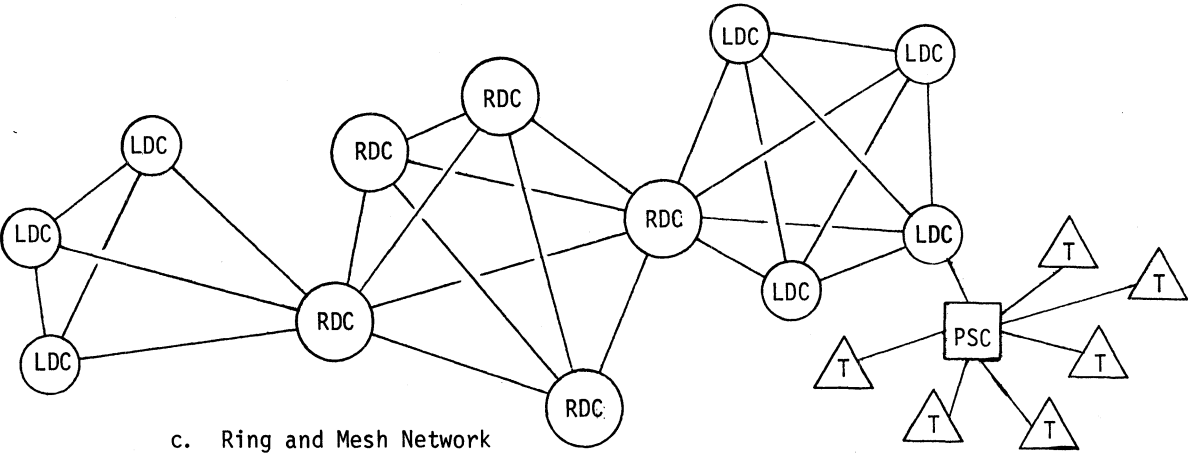

c. Ring and Mesh Network





-  Regional data center
-  Local data center
-  Public telephone switching center
-  User terminal

Figure 16. Typical Data Network Distribution Architectures.

(CCITT, 1979c). Packet switching may reduce considerably the complexity of a mesh configuration which requires interconnecting of all regional data centers. As shown in Figure 17, new or updated information would be entered into the packet-switching center. All data packets (or in some cases selected data packets) destined for a specific address would be packet-switched to regional VIDEOTEX data centers for storage.

Interactive VIDEOTEX services would then follow the "normal" routine: customer requests for information would be entered on a call-up basis to the local VIDEOTEX regional data center via the local telephone switching center. Messages or pages of data would be handled in the usual fashion. As may be noted from the sketch, certain terminals would also have provision at ports for information data entry. Such information could likewise be introduced into the packet-switching node for distribution to other centers.

Packet Switching

The advantages of packet switching from both communication and economic points of view have been discussed at length in the literature (e.g., Halsey et al., 1979) and will not be covered in detail here. (See Section 5 of this report for discussion of switch technology.) For interactive VIDEOTEX services, information of local interest may still be entered and stored by transactions, via the telephone, into regional or local data centers. For information of widespread or national interest, the packet-switching entry may provide both a more rapid and a more economic way of transmitting this information throughout the VIDEOTEX network.

In communication via circuit-switched networks, the interconnection is held for the duration of a call. The line remains idle when no messages are being transmitted; this may result in long periods of idle time between calls when using circuit switching for transactional or interactive applications. Packet switching was developed to more fully utilize the network for mixes of low-volume and intermediate-volume data subscribers. Network paths are essentially shared among many users by arranging and transmitting messages as "packets" or blocks of information. Each packet contains a network-defined header which contains addressing information, size of packet, and number of packets per message: that "overhead" information required for forwarding the user-destined information through the network.

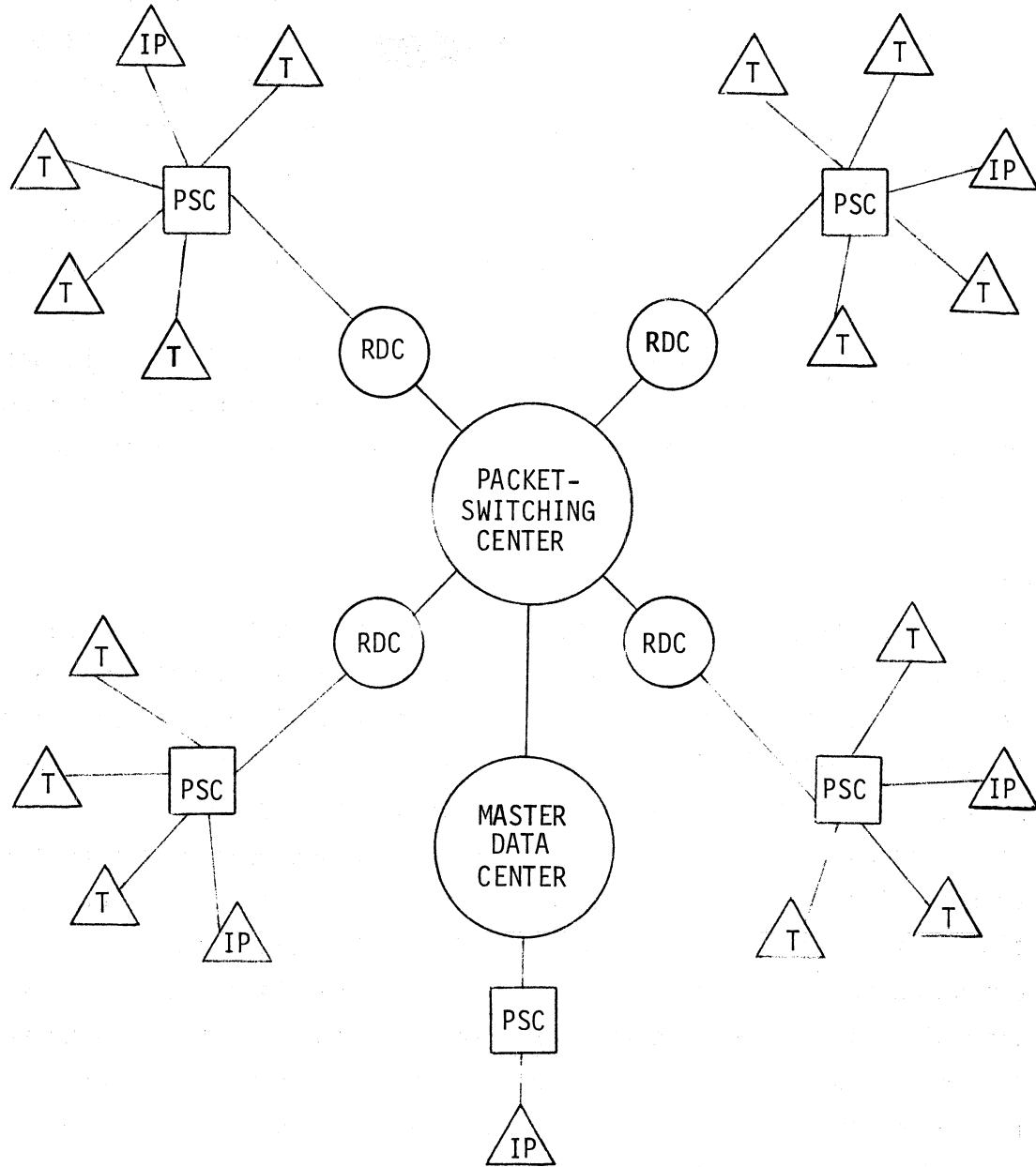





- 
Regional VIDEOTEX data center
- 
Public telephone switching center
- 
Information provider
- 
User terminal

Figure 17. VIDEOTEX Packet-Switched Network.

Buffers may be provided to store and properly queue packets to their proper destination. From the customer point of view, the system appears to be a point-to-point connection between the customer terminals. From the network switch (and system) point of view, packet switching may alleviate many of the problems which result from heavy, intermittent loading of network circuit-switching centers. Packet-switched networking is suggested as an alternative to these conventional systems for handling low- to moderate-volume data transactions.

4.2. Centralized Network Services

AT&T is rapidly implementing its electronic switching systems, both for local switched network applications and for regional high speed toll switching. The heart of the electronic switching centers, whether No. 1 ESS or No. 4 ESS or any other hardware within the growing hierarchy, consists of central processors and software system which control network operations. In addition to conventional call routing, specialized services (such as address store and forwarding) can be and are being offered to the public. To give an example of the numerous such services now available, Table 13 lists features available from AT&T for a modern PBX. Such specialized subscriber services make use of central data storage and processing integral to the switched telephone network.

This has suggested to Bell Telephone Laboratories that additional features, such as message storage and forwarding--and perhaps even VIDEOTEX services--could be offered to the subscriber, operated from within the telephone network and using its central processing system. This type of networking may be significantly different from the network "attachments" suggested in the preceding subsection.

A new information system proposed for the switched network (Williams et al., 1979), would allow voice communication among people separated both in space and time. (Some discussion of this system also appears in Section 2.6. Known as the Bell System 1A Voice Storage System (1A VSS), this new service would permit delivery of a spoken message into the network for almost immediate retrieval (seconds) by one or more addressees of the specific message. The 1A VSS would have the ability to record or retrieve hundreds of such messages in parallel without the subscriber finding it necessary to wait either to input or output the system. This is in contrast to serial recording on magnetic tape, with inherent access lag time.

Dimension® PBX Program No. 2 Features.

Alphanumeric Display for Attendant Position	Outgoing Trunk Queuing
Calling Number Display to Attendant	Power Failure Transfer
Class of Service Display to Attendant	Privacy and Lockout
Incoming Call Identification	Recall Dial Tone
Attendant Console	Recorded Telephone Dictation Access
Attendant Control of Trunk Group Access	Remote Access to PBX Services
Attendant DSS with Busy Lamp Field	Restrictions:
Attendant Lockout	Fully Restricted Stations
Attendant Transfer—All Calls	Inward Restriction
Automatic Callback—Calling	Manual Terminating Line Service
Automatic Identified Outward Dialing (AIOD)	Miscellaneous Trunk Restriction
Busy Lamp Field	Origination Restriction
Busy Verification of Station Lines	Outward Restriction
Call Forwarding—All Calls	Termination Restriction
Call Forwarding—Busy and Don't Answer	Rotary Dial Calling
Call Hold	Route Advance
Call Pickup	Serial Call
Call Waiting Services:	Splitting—1-Way Automanual
Attendant	Station Hunting:
Originating	Circular
Terminating	Terminal
CCSA Access	Station to Station Calling
Code Restriction	Straightforward Outward Completion
Dial Access to Attendant	Switched Loop Operation
Direct Inward Dialing (DID)	Tandem Tie Trunk Switching
Direct Outward Dialing (DOD)	Threeway Conference Transfer
Direct Trunk Group Selection	Through Dialing
Distinctive Ringing	Tie Trunk Access
Executive Override	Timed Reminders
Flexible Numbering of Stations	Toll Restriction—Battery Reversal
Foreign Exchange (FX) Access	Toll Restriction—O/I (Limited 3 Digit)
Incoming Call Identification	TOUCH-TONE® Calling Capabilities
Intercept Treatment	TOUCH-TONE to Dial Pulse Conversion
Line Lockout with Warning	Trunk Answer from Any Station
Listed Directory Number Service	Trunk Group Busy Indicators on
Loudspeaker Paging	Attendant Position
Basic	Trunk Group Warning Indicators on
Deluxe	Attendant Position
Multiple Listed Directory Numbers (Non-DID Only)	Trunk Verification by Customer
Night Console Position	Trunk to trunk Connections
Night Station Service—Fixed	Two Party Hold on Console
Night Station Service—Full Service	WATS Access
Off-Premises Stations	Wide Frequency Tolerant Power Supply

Table 13. Features available for a modern PBX. (Source: AT&T).

The authors of the paper suggest the possibility of a Prestel-like service incorporating both textual display and some form of IA VSS. They suggest a system which "...could be used to select voice announcements from a large collection in storage...", and they point out that "...once voice was added to a Viewdata (interactive VIDEOTEX) system, there are many other (information system) possibilities for mixed audio/video presentations..."

It is interesting to speculate on the enhanced capabilities of a VIDEOTEX system which provides both the "page" presentation in alphanumeric or graphic form and an accompanying voice announcement. It is not unreasonable to expect that the common carrier operating companies are speculating over the network incorporation of VIDEOTEX services in which the storage and retrieval equipment is imbedded deeply into the switched system. This would be unlike any of the proposed network architectures where the VIDEOTEX services are overlaid on the existing telephone network, and which may be privately leased (or owned) and operated. VIDEOTEX services built into the common carrier network would also have other ramifications which would relate to regulatory, policy, and tariff considerations.

4.3. Network/Systems Protocol and Computer Architecture

Transfer of information or distribution of data from a central data bank such as with interactive VIDEOTEX systems will have some probability of corruption due to noise, transients, etc. in anything other than an ideal system. It is the desire of every design engineer to provide the best transmission system at a cost compatible with the requirements of the users. For example, tradeoffs exist, from the very beginning of a system design, involving how many errors the user can tolerate. Some users will even state that no errors are acceptable. This can be implemented at a reasonable cost, but, if the transmission medium deteriorates, then the throughput (messages transferred without error) drops drastically. The limiting case would be the absurd situation that it takes infinitely long to transfer a single message perfectly on a noisy channel.

Depending on system layout and information flow, various schemes have been devised to preserve the integrity of the messages. These schemes may be referred to as the protocol for the system. Sophisticated protocol which maintains high throughput with near error-free performance not only costs a lot, but may depend

on having a certain minimum set of hardware (computer architecture) available. This section discusses protocol and the impact of rapidly changing computer and peripheral architecture on information transfer and storage. As mass memory becomes cheaper, more store-and-forward systems will be developed, causing a major impact through the use of distributed and shared communication systems with smart nodal control.

4.3.1. Communications Protocol

There are three basic types of protocol used when information is exchanged from one place to another:

1. Exchange without regard to errors.
"I sent it, did you get something?"
2. Exchange with errors flagged.
"You sent me something, but it had a few errors."
3. Exchange with provision to correct errors or retransmit the message.
"I got your message, but it has errors; standby while we correct it (or retransmit it)."

The first method is obviously not a very desirable way to send valuable data since no credibility is possible. However this represents both the cheapest and fastest method to transfer information. The second method has been widely used because it can be implemented in a rather inexpensive manner with a low overhead. An example of this style of error detection is the parity bit (8th bit) used with ASCII code information. If data is received in error it can easily be flagged by printing or displaying some unusual character such as  (which many terminals have) in place of the interpreted character. While this simple protocol is useful, it is not very satisfying to the user with a noisy line to have one of these characters appearing in every other line, especially if the page contains a large amount of numbers, rather than pure text. If flagging of errors does not meet the user requirements, then error detection and correction or retransmission may be the only solution. This represents a much greater degree of system sophistication than the first two methods of information exchange. This third method also adds appreciable (and sometimes intolerable) overhead to the transmission time. The retransmission capability requires full duplex (simultaneous two-way) communications or at the very least a half duplex circuit with turn around capability. The usual procedure for this third method is to transmit data in blocks with each block having a

header and trailer that contain information on the data within the block according to some predetermined algorithm. The receiver must process the data and determine if it matches the information provided by the overhead information. If so, the data is assumed correct and used; if not, either a retransmission or correction must be made, provided the protocol is elaborate enough to handle the error. Depending on how noisy the communication link is, the overhead from this third method could reduce throughput from 10% to 50% of the throughput obtained in method 2. An example of this third method is the widely used IBM protocol (3780 protocol).

4.3.2. Computer Architecture

The capabilities of any information distribution system are determined by the type of hardware and software used. Normally the larger systems will handle more customers and traffic and cost proportionately more than smaller systems. It should be noted however that most computer systems' processors are generally used a small percentage of the time. (Ten percent or less is not uncommon.) If a computer's central processor unit (CPU) is busy more than 50-65 percent of the time, users may begin to notice delayed response. Ideally a CPU should be occupied 10-40% of the time. The late 70's have seen the blending of features from micro-, mini-, and maxi-computer systems. This is due to the rapid advances in Large Scale Integration (LSI) of transistor (solid state) circuits onto very small chips, and improved mass storage devices, primarily magnetic media in this decade. The early 1980's will see many fast "hard" disks taking the place of 1970's flexible disks at twice the price of today's disks, but having 100 times the storage and 1/100 the access times. Thus the performance/cost factor will increase by a factor of 50. Solid state memory is currently dropping in price about a factor of two every two-three years. The impact is that we will have more information available to transfer faster than we presently know how to handle it.

An example of computer architectice design trends is that computers are now being built with not one microprocessor, but several: one for the CPU, one for input/output (I/O), one for memory handling, one for mass storage, etc. The micro-computer for the Green Thumb County Processor will contain two Z-80 microprocessors, one to handle the normal CPU functions and one to handle the communications traffic. This has the advantage of being able to expand the number of communications lines without taxing the CPU in the same manner as the conventional single processor

system. By adding more communications modules (i.e., more of the Z-80's), the number of lines would be expanded in increments of 16 until the CPU Z-80 bogs down. However, by replacing the CPU chip with a faster, upward-compatible CPU chip, then the system could expand again. If the limitation were in the flexible disk speed, then the new small Winchester technology hard disks could relieve that problem.

In summary it can be said that the microprocessor technology is making the small computer look like the large computer of just a few years ago. Its enhanced functions at a reasonable price will speed the information dissemination process, provided the communications systems can handle the traffic. Forward error correction, which becomes easier to implement with more sophisticated LSI and microprocessor technology, will further increase the bandwidth requirements for information exchange. Thus as the protocol and architecture problems are solved, the traffic and loading problems will become worse.

5. IMPACT OF VIDEOTEX SERVICES ON THE LOCAL LOOP

This discussion is concerned with the effect that information systems have on the communications networks they use - both now and in the future. The impact is considered from the carriers' viewpoint (facilities required) and the users' viewpoint (grade of service provided). Emphasis is on interactive VIDEOTEX information systems such as Prestel and Green Thumb, which utilize the public switched telephone network for information exchange.

Interactive information systems, in the context used here, are defined as one class of teleprocessing systems whose function is characterized by a dialog between man and one or more data processing systems. The user of such an information system acquires desired information by conversing with a data bank. Thus, user-access information systems require two-way communication links between many users and a common source of data. This is in contrast to information distribution systems which provide one-way "broadcast" service only.

In this discussion our concern is with certain specific information systems, their transmission links, and their switching nodes. The links and nodes provide the information transfer facilities.

Switch nodes provide access to a common source, the data bank, by a multiplicity of users. This is accomplished by concentrating the interactive data traffic from the many users onto a lesser number of trunking facilities. Access to the data bank may be restricted or blocked due to congestion at the switch or on the trunks.

Important questions we hope to answer include the following: What type of network switch should be used? How many trunks are required? How can the traffic be estimated? What about future networks and systems?

In this introductory note we can only introduce some general concepts and develop approximate answers using simplified models. A more detailed study is required before the full impact can be evaluated.

5.1. Switch Technologies and Selection Criteria

Telecommunication switching systems in use today fall into two basic categories: circuit switches and store-and-forward (S&F) switches. (See Figure 18.) Circuit switches are commonly used in the public switched telephone network where connections are established for continuous two-way speech conversations. Circuit switches may be distinguished by two basic elements: the switching matrix or crosspoints used, as in Figure 18, and by the control technology employed, as in Figure 19.

Store-and-forward (S&F) switches are commonly used for data transfer. They are more efficient and economical for this purpose. Store-and-forward switches may be categorized by the method used to format the message (e.g., length and header used). The format affects the delay encountered in transmission. Message S&F switches handle long messages with short headers and introduce long delay. Packet S&F switches handle short messages ($\lesssim 1000$ bits) and introduce much less delay.

Specialized common carriers provide both message and packet-switched service in the U. S. Hybrid switches which combine both circuit and S&F technologies have been proposed and may be used in the future.

These different switch technologies are suited to different kinds of traffic. The circuit switch is inherently a two-way transparent device. It is ideal for handling continuous traffic with long holding times. Circuit switches provide real time connections between compatible terminals such as the telephone. Blocking due to congestion in the switch may occur.

The message switch is inherently a one-way device. It is essentially non-blocking, although long delays in message delivery may occur. Message switches are suitable for handling traffic requiring large throughputs and high reliability. Examples of terminals generating this kind of traffic are teletype and facsimile.

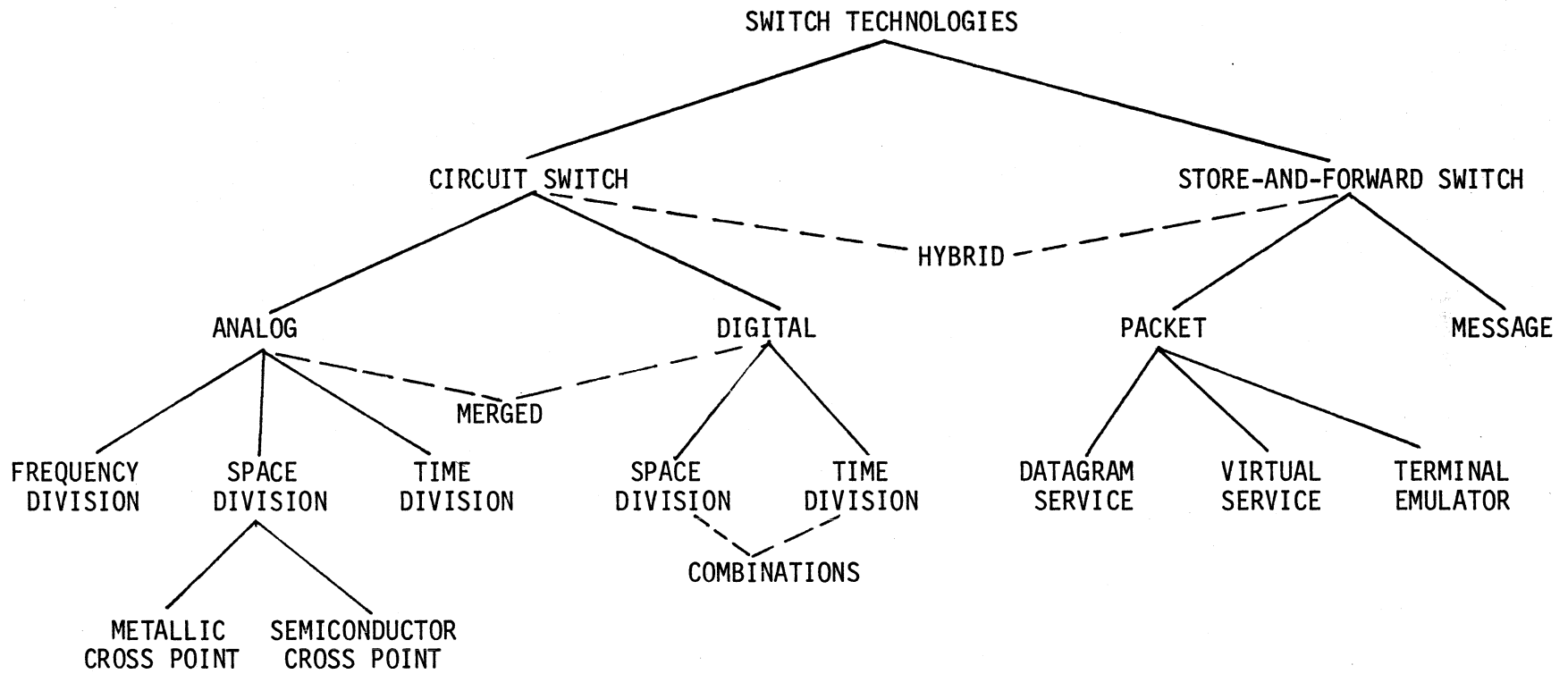

Figure 18. Breakdown of switch technologies.

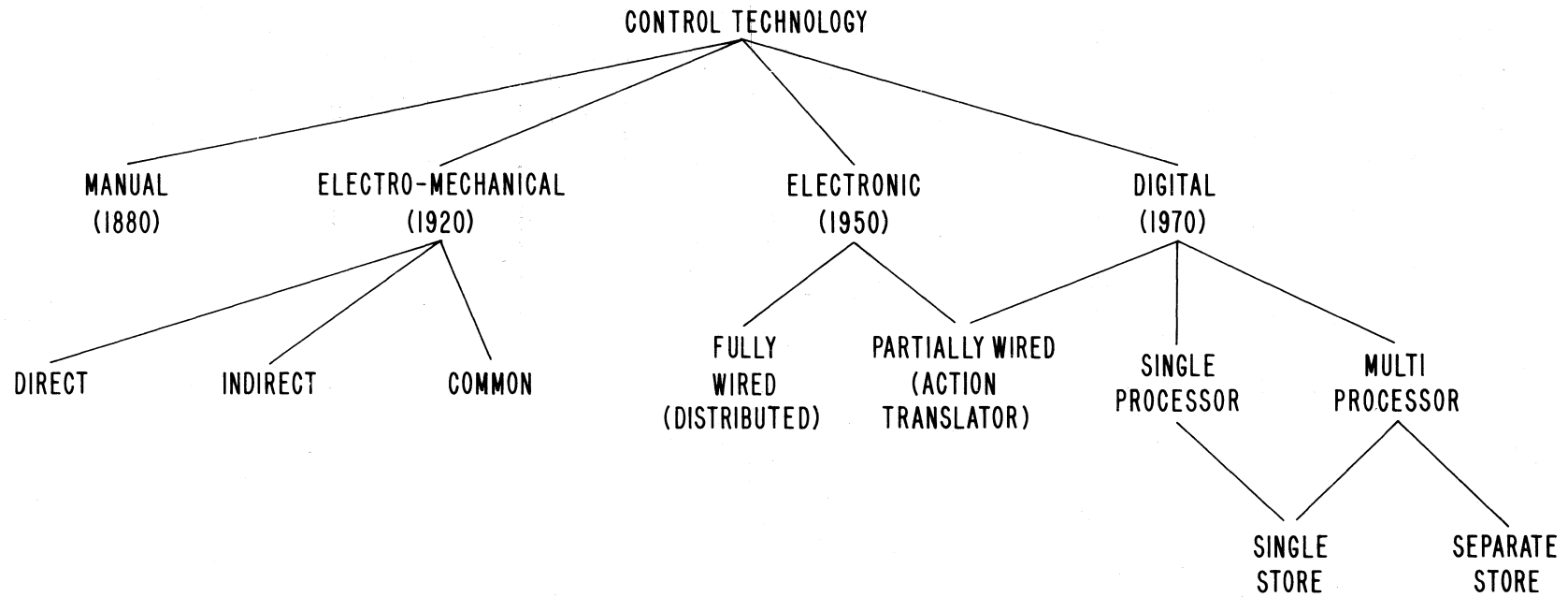

Figure 19. Control technologies and approximate year each has been introduced.

This traffic may be interrupted with no degradation in the ultimate service provided, except a delay. Terminals need not be compatible in all parameters since mode, code, and speed conversion can be accomplished at the switch.

The packet switch is designed to handle interactive traffic of a bursty nature. Examples of terminals generating such traffic are query-and-response systems such as host computers and their terminals. Interactive information systems often fall into this traffic class.

Figure 20 summarizes the relationship between three traffic types, switch applications, and desirable network properties. The desirable properties are large throughput, high reliability, and short delay. These are shown in Figure 20 as sides of a triangle. As one approaches any given side, the desirability of a property increases. Thus, at any apex, two properties coexist with a detriment to the third. Selected switch types used to achieve the apex conditions are indicated on this figure.

Interactive information systems logically fall under the interactive traffic and packet-switch category. However, the widespread use of the circuit-switched telephone network, with terminations in nearly every house, makes it a serious contender for use by information systems. Telephone circuits can be reasonably adapted for data transmissions. Telephone stations are replaced with modulators and demodulators (modems), and data subscribers connect data terminals or processing systems to the modems. The 3 kHz bandwidth of the conventional telephone circuit permits half-duplex data rates of 2400 b/s using fairly simple equipments. Full duplex operation at 1200 b/s is also common. In rural areas, data rates may be decreased to reduce errors over noisy channels.

With special conditioned lines and equipment, rates up to 9600 b/s have been achieved over phone lines. Error rates on these circuits are on the order of 10^{-5} . Error detection codes and retransmissions can be used to reduce error rates to any desirable level with a sacrifice in rate of throughput.

The impact of information systems on the network and vice versa depends upon the type of switching that is used and the kinds of traffic generated. Telephone companies tend to disfavor many users with low traffic being concentrated to one terminal (the computer) with high traffic. This puts a high burden on trunking facilities.

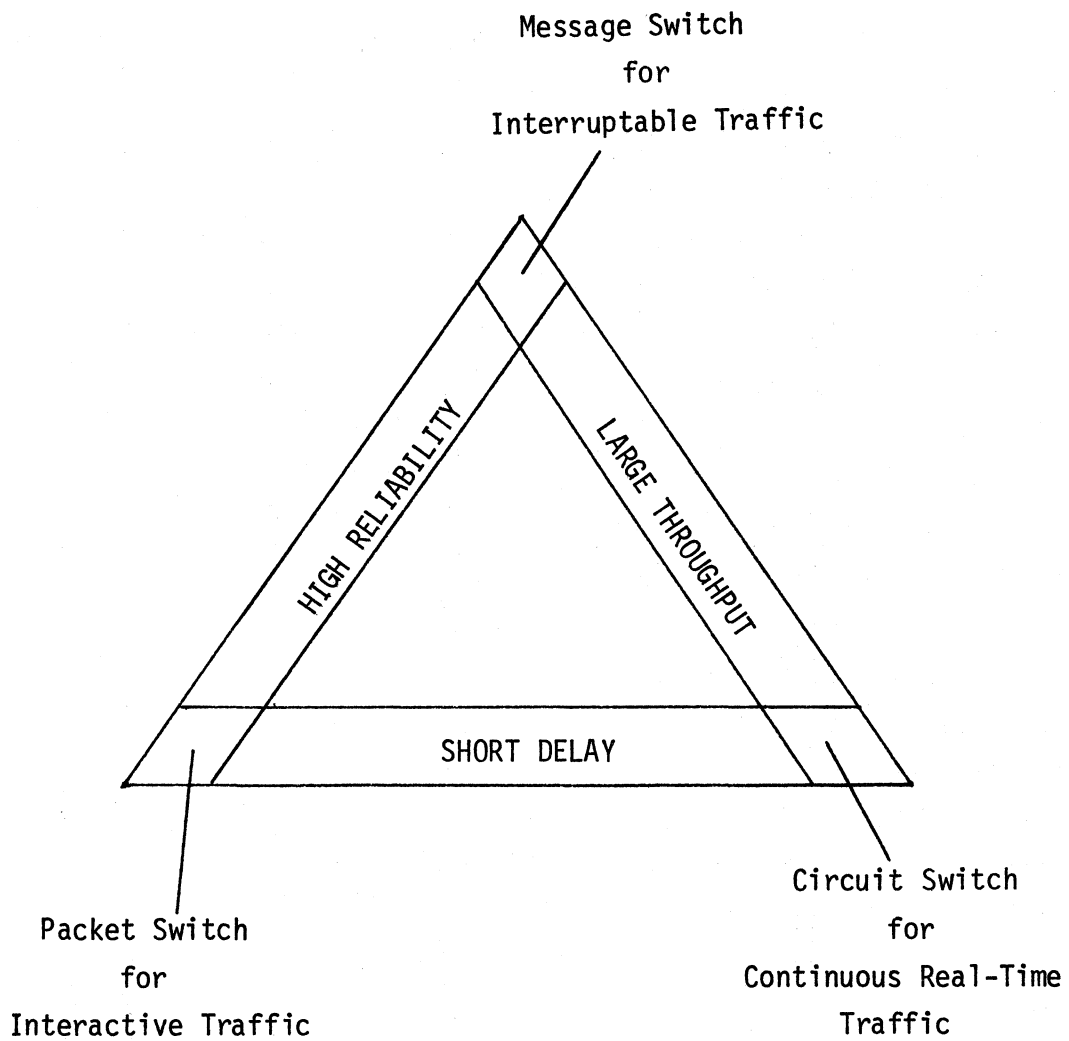

Figure 20. Relating network properties to switch technologies.

In the following subsection, the effect of traffic on switch design and capacity are considered. Then in Section 5.3, two information systems are described. The effect on circuit switch capacity when such systems are implemented is then evaluated.

5.2. Traffic Considerations And Switch Capacity Limitations

Circuit switch design requires knowledge of the expected traffic which the switch must handle. Traffic data of interest includes calling rates and holding times. The switching system can then be structured to provide a grade of service acceptable to users terminating on the switch. Grade of service parameters include the probability that a call will be blocked and lost or the probability that a call will be blocked and delayed.

Switch capacity is a multidimensional quantity. Defining parameters pertain to basic switch elements. For a circuit switch, the capacity may be limited by 1) the number of terminations (lines and trunks) and their offered load, 2) the switching matrix and the load it can carry, 3) the control element and the number of call attempts (CA) it can handle, and 4) the signaling element and the speed by which it can remotely control the switch. Items 1 thru 3 are the primary concern here since it appears that the signaling element is usually not the principal limitation on switch capacity.

A telephone network user generates traffic over his local loop. This traffic from many such users is the offered load to the switch at an end office. The average traffic intensity or offered load per user is a function of the calling rate, λ , and the average holding time, τ .

The calling rate, λ , tends to occur randomly. It may be specialized as the average number of call attempts per hour. Traffic engineers measure traffic on operating systems to obtain information for design purposes. From these data, the average number of busy hour call attempts for the busy season is calculated. The table below is an example of such data for five work days and selected hours.

	M	T	W	T	F	TOTALS
8 - 9 AM	800	650	700	750	<u>980</u>	3880
9 - 10 AM	<u>900</u>	895	<u>1000</u>	745	960	<u>4500</u>
10 - 11 AM	760	<u>925</u>	850	690	775	4000
2 - 3 AM	830	900	980	<u>820</u>	600	4130

Note in the table that the busiest hour (underlined) varies between days of the week. The busy hour expressed as calling rate per week (underlined total) is often used to determine switch control elements' capability for handling calls. Extra margin is added to handle peak traffic loads during any hour.

Holding times depend on the caller. Typical values range from three to five minutes. The actual distribution shows variations over a large range. The distribution tends to be exponential.

The average parameters λ and τ determine the traffic load, A , offered per user as follows

$$A = \lambda\tau .$$

The international unit of traffic load is a dimensionless quantity called the Erlang. One Erlang of traffic on a line implies continuous occupancy of that line. Thus 1 Erlang = 1 call hour/hour = 1 call second/second. In North America, traffic load is usually expressed in terms of hundred call seconds per hour and is abbreviated CCS. One Erlang equals 36 CCS/hr.

Traffic intensity as a function of call attempts per hour and holding time per call is given by Figure 21. The shaded areas on the figure indicate desirable operating ranges for line and trunk traffic in a typical circuit switched network. Interactive and bulk traffic regions shown are less desirable. For these types of traffic, the circuit-switched network is uneconomical. It is more practical to lease dedicated circuits or to use a different switching technique.

Figure 22 relates to a number of basic parameters used to characterize a circuit switch. Given a few of these parameters, the others can be determined. For example, given a 3000 line switch, 0.1 Erlangs per line, and two minutes average holding time, we can determine the control and matrix capacity. The overlay square on Figure 22 demonstrates the method. The resulting switch parameters are:

Total Terminations	3000
Load/Line (Erlangs)	0.1
Holding Line (hours)	0.033
Call Attempts/hr/line	3
Call Handling Capability (CA/h)	4500
Matrix Load (Erlangs)	150.

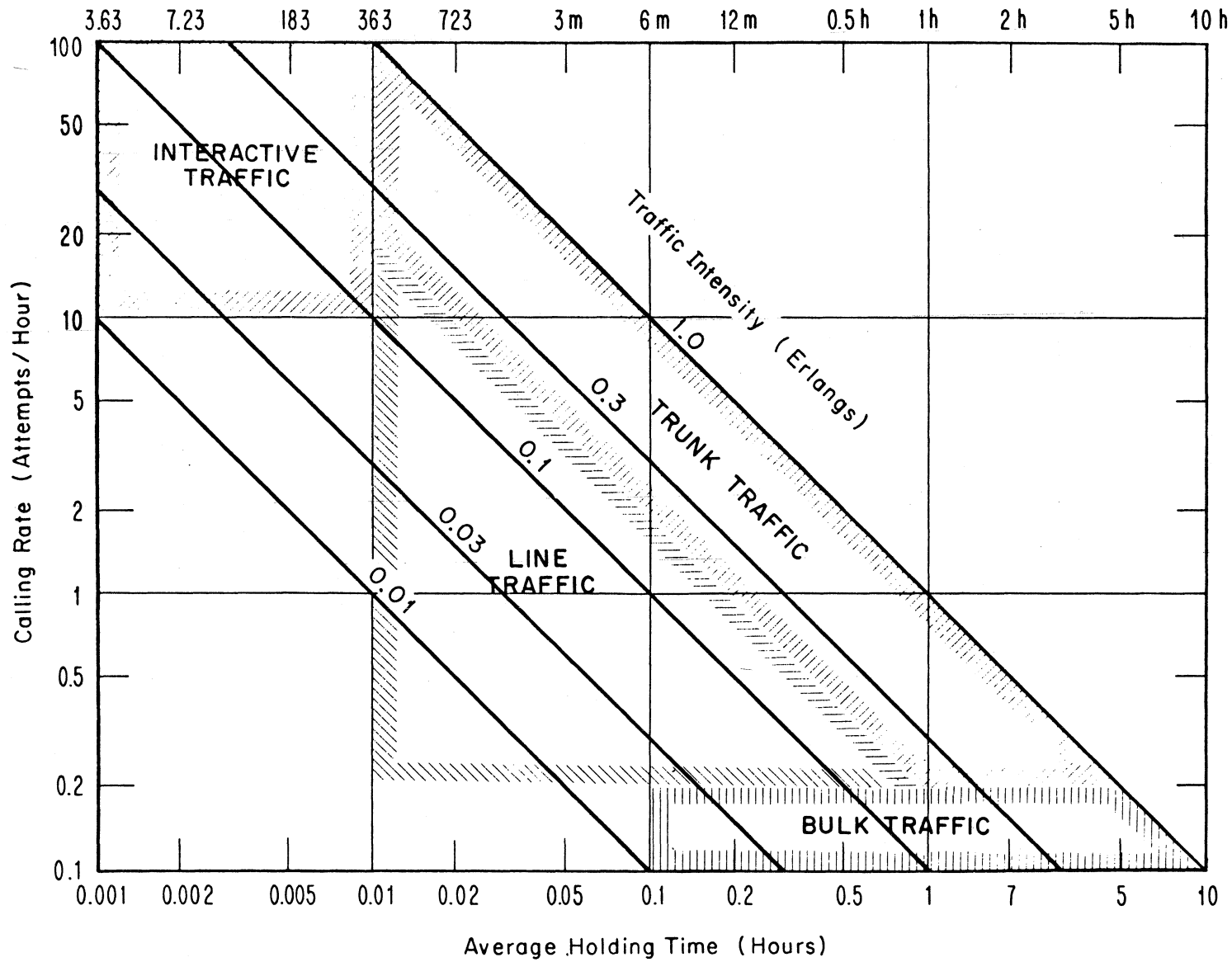

Figure 21. Approximate operating ranges for line and trunk traffic.

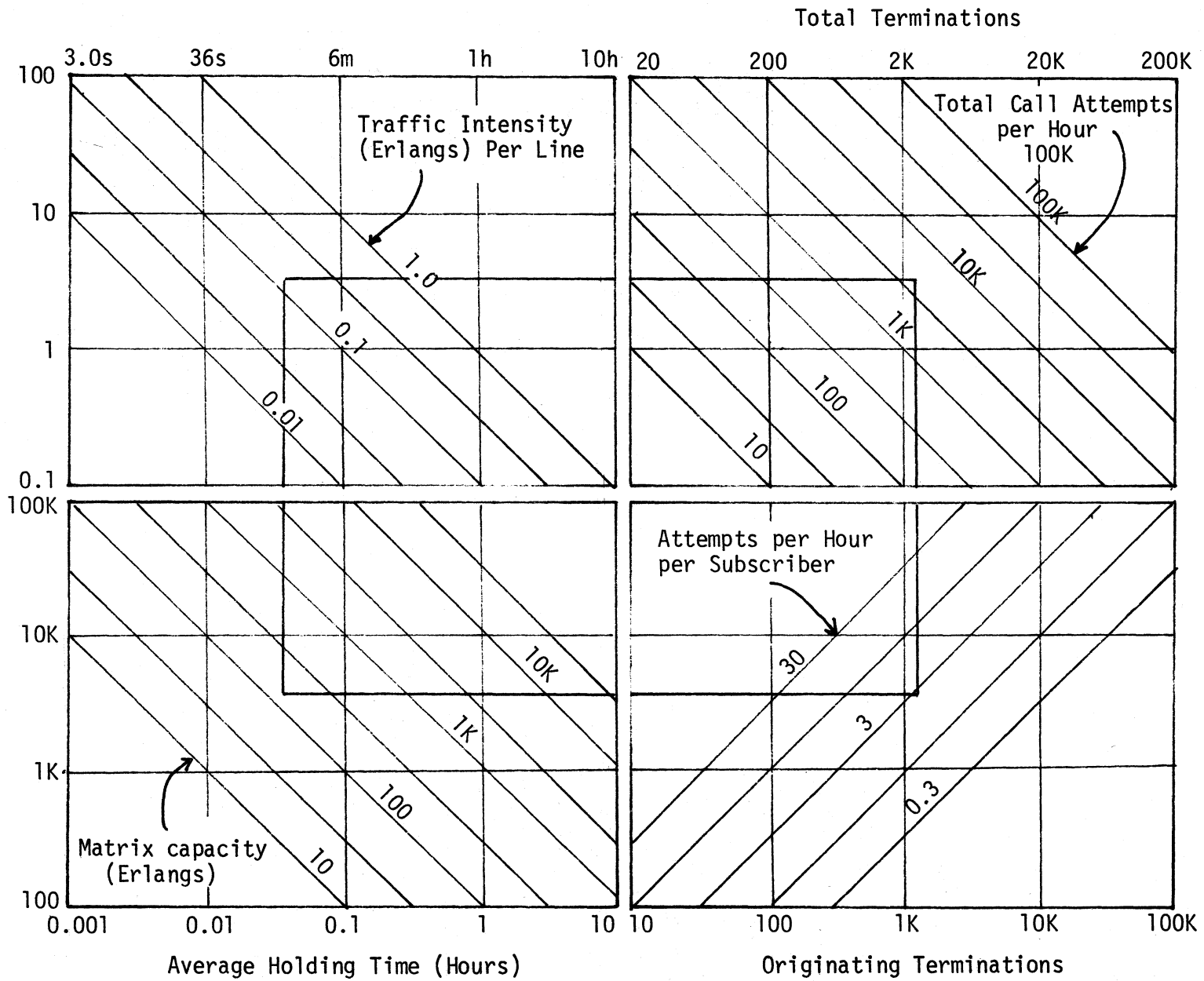

Figure 22. Relating basic switch parameters.

The figure is useful for determining the impact of implementing an information system using this switch. Assume that installing such a system increases the busy hour traffic load to 0.15 Erlangs; the average holding time remains the same. Then the switch control would now have to handle 6750 call attempts/hour and the load carried by the matrix increases from 150 Erlangs to 225 Erlangs.

The impact by a specific information system on a 20,000 line switch is described in the next section.

5.3 Broadcast and Interactive System Concepts

Three different examples of systems--Ceefax, Prestel, and Green Thumb--are used here. Ceefax is a distribution type system whereby the entire data bank is continuously transmitted via TV broadcast signals. Data rates of about 1 Mb/s are achieved by modulating the TV return trace. Ceefax users select desired information frames for display on the TV raster. No separate link is required back to the source since all data is broadcast on a continuous repetitive basis. Such broadcast VIDEOTEX systems have, of course, no effect on the telephone network.

Prestel and Green Thumb are user-access information type systems. Both operate in the interactive mode using a switched telephone network. Information is requested and received via the network and displayed on a subscriber's TV set. One basic difference between these latter two systems is the line access and holding time. The Prestel system requires a continuous access line while in use. The Green Thumb system stores request data and information-received data in the terminal. The line is connected only during transmission periods. Table 14 summarizes some pertinent characteristics of these three systems.

In the following paragraphs we discuss in more detail the Prestel and Green Thumb concepts. Their differences are noted so that their impact on the switched network can be ascertained. It is assumed in both cases that the public switched telephone network is used for information transfer.

In both the Prestel and Green Thumb systems, the maximum information flow is downstream from the data bank to the user. The upstream flow (user to data bank) is request data containing numbers of the data bank pages or blocks desired by the user. The maximum number of pages or blocks transmitted downstream during any one call depends on the storage facilities available at the users terminal.

With the Prestel system, a typical display may contain 24 rows of alphanumeric text with 40 characters per row, yielding a total of 960 characters. Each character is encoded with seven bits using the ISO-7 subset of the American Standard Code for Information Interchange (ASCII), which allows for the substitution of national

Table 14. Pertinent Characteristics of Some Commercial Systems

SYSTEM NAME	CEEFAX	PRESTEL	GREEN THUMB
SYSTEM TYPE	INFORMATION DISTRIBUTION	USER-ACCESS INFORMATION	USER-ACCESS INFORMATION
OPERATION MODE	BROADCAST	CONTINUOUSLY INTERACTIVE	INTERMITTENTLY INTERACTIVE
TRANSMISSION MEDIUM	TV RETURN TRACE	SWITCHED NETWORK	SWITCHED NETWORK
TRANSMISSION RATE:			
• DOWNSTREAM	1 Mb/s	1200 b/s	300 b/s
• UPSTREAM	-----	75 b/s	300 b/s
FRAME CAPACITY	~ 9.6 K BITS	~ 9.6 K BITS	~ 4 K BITS
STORAGE RQMTS.	4.8 K BYTES (4 VIDEO FRAMES)	4.8 K BYTES (4 VIDEO FRAMES)	4 - 8 BYTES (8-16 VIDEO FRAMES)
DISPLAY	SUBSCRIBERS'S TV	SUBSCRIBER'S TV	SUBSCRIBER'S TV

characters such as the £ sign. Two additional start and stop bits plus a parity check bit are added, making a total of 10 bits per character and 9600 bits per video frame.

The downstream transmission rate is typically 1200 b/s, so one frame is transmitted in eight seconds. Requesting the information is accomplished at a lower rate of 75 b/s. If a request requires 10 characters at 10 bits/character, this added $100/75 = 1.3$ sec per page. We will assume that the total time per frame is 10 sec/call.

A medium size end office may serve 20,000 subscribers. Let us assume that, on the average, each subscriber makes two "conventional" telephone calls attempts per busy hour and averages three minutes (.05 hours) per call. Then the average load offered per line is 0.1 Erlangs (E). Since half the subscribers could be calling the other half at any one time, the maximum load carried by the switch is

$$\frac{20,000 \times 0.1}{2} = 1000 \text{ E .}$$

This situation is shown in Figure 23a. Now assume that a Prestel type information system is implemented through the same end office. During the same busy hour, 10% of the subscribers may be using the Prestel system. Assume these Prestel subscribers make three calls/hour to the data bank, requesting 10 pages/call at 10 seconds per page [i.e., 100 secs. holding time/call]. Then the load carried by the

switch via trunks to the data bank is $2000 \times \frac{100}{3600} \times 3 = 167$ Erlangs. The other

18,000 subscribers are calling as before. The selection is shown in Figure 23b. The maximum load carried by the switch matrix is now 1067 E, an increase of 6.7%. However the total number of calls that must be handled by the switch control element has increased from 20,000/hour to 24,000/hour, an increase of 20%. This simplified illustration indicates that the switch capacity--particularly the control capabilities--can be affected disproportionately by widespread use of an information system. Adequate switch capacity margins are usually included (when switching systems are installed) to take care of peak traffic periods. The limitations on a switch may be exceeded only when traffic loads offered by information systems occur during the busiest hours of a day. It was assumed in the example that all subscribers could have access thru the switch simultaneously. This of course is very unlikely. (A 10,000 termination end office might have 1,000 calls in progress and only 100 in the process of setting up a call at any given instant. The result however would still apply on a relative basis.)

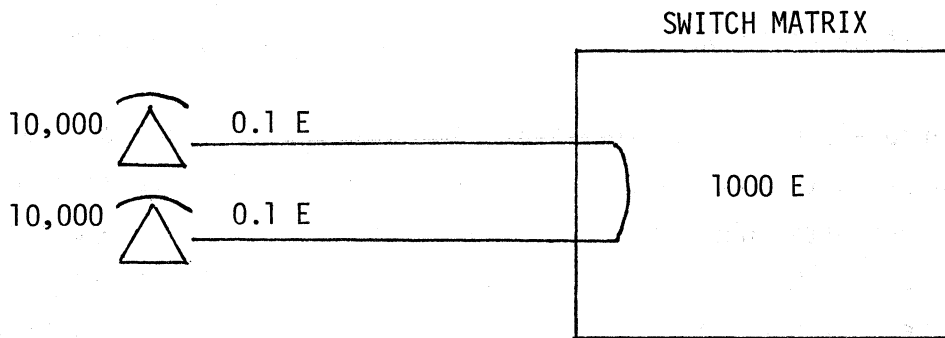

Figure 23a. Example of normal load carried by end office with 20,000 lines.

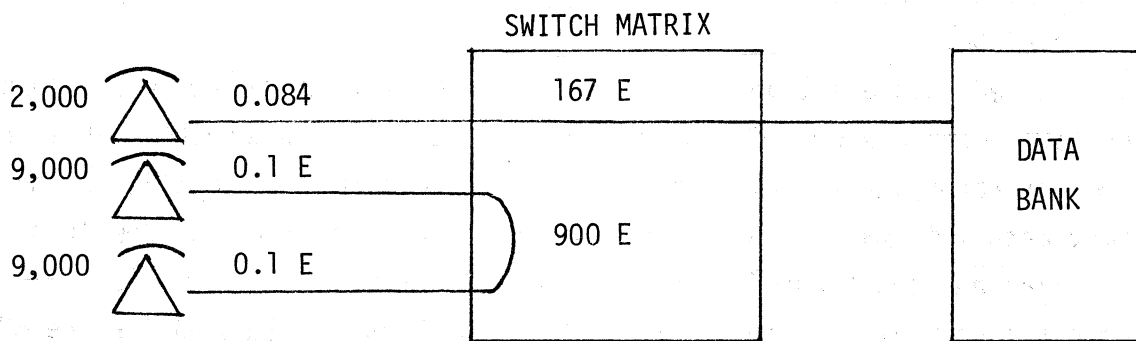

Figure 23b. Load carried by end office assuming 10% of calls are trunked to data bank.

The Green Thumb system is being developed for use in rural areas to provide farmers with marketing, weather, and other types of information. The system being implemented for test purposes operates at 300 bits/sec. Access to the data bank is via the public switched telephone network. The user requests information in blocks. Each block is 512 bytes (4096 bits) long. This is approximately equivalent to 1/2 frame for the Prestel system. The blocks are stored in memory at the user's terminal using either 4K or 8K bytes of memory, corresponding to 8 or 16 blocks of data.

Assuming error-free transmission and a 4K memory unit, then it takes approximately 2.3 minutes to transmit and store 8 blocks at 300 b/s. Up to five retransmissions may be requested when errors occur. In the following sub-section, these characteristics of the Green Thumb system are used to indicate the effect on congestion at the switch due to inadequate trunking facilities to the data bank. The grade of service is calculated in terms of blocking probabilities as a function of the number of trunks used to the data bank from the end office.

5.4. Grade of Service Estimates for Green Thumb Test Bed

Teletraffic engineers use a variety of traffic models based on different assumptions to predict the performance of telecommunications networks. Estimates obtained will vary with the model used. For designing trunk groups to a data bank, it is necessary to estimate the load offered to the group and then select the group size depending on the desired blocking probability. This is done in Table 15 for the Green Thumb test bed.

It is assumed that all trunks have full availability at the switch. One hundred subscribers are furnished with Green Thumb equipment. Each subscriber makes one call attempt/hour at random, but during the same hour. To simplify the calculation we have assumed each information call requires one 2.4 minute period of download time for a quiet line and two transmissions (4.8 min.) on a noisy line. This is for the 4K byte memory system at the user terminal. The numbers are doubled for the 8K byte memory system.

Traffic engineering tables were used to estimate the percentage of calls which would be lost under these conditions. Two different models were used. The "lost model" assumes blocked calls are not reentered into the system (Erlang B). The "held model" assumes blocked calls are held until they can be served (Poisson). Both models assume random call attempts, exponential holding times, and infinite sources. Results are shown in Table 15 for 7, 14, and 21 trunks to the data bank.

Table 15. Blocking Estimates for Green Thumb Test

	4K MEM		8K MEM	
	QUIET	NOISY	QUIET	NOISY
CA/HOUR	1	1	1	1
HOLDING TIME	0.04 h	0.08 h	0.08 h	0.16 h
OFFERED LOAD PER SUBS.	0.04 E	0.08 E	0.08 E	0.16 E
BLOCKING %				
<u>7 TRUNKS</u>				
LOST MODEL	6%	35%	35%	65%
HELD MODEL	11%	68%	68%	98%
<u>14 TRUNKS</u>				
LOST MODEL	< 0.1%	3%	3%	25%
HELD MODEL	< 0.1%	3.5%	3.5%	70%
<u>21 TRUNKS</u>				
LOST MODEL	NONE	NONE	NONE	5%
HELD MODEL	NONE	NONE	NONE	16%

It is apparent from Table 15 that seven trunks are probably insufficient except possibly for the 4K memory and quiet channel situations. Under noisy channel conditions (4K memory) or quiet conditions (with 8 K memory), the percentage of calls blocked is reduced by more than one order of magnitude by doubling the number of trunks from 7 to 14. With 21 trunks serving 100 subscribers, no blockage occurs except under noisy conditions and 8 K memory.

5.5. Future Concepts

This preliminary discussion has considered the impact of information systems only on the public switched telephone network. The reason is basic: this network already provides two-way communications to a large percentage of homes in the U. S. In the future, other types of networks could be used as they become more prevalent. This includes satellites, cable TV systems, and packet-switched networks provided by specialized common carriers. Packet-switch networks, such as Telenet, are already accessible for data transmission over long distances. (See Appendix A.6 for discussion of proposed U.S. systems employing these transmission media.) However, subscriber access is still primarily via local telephone loops.

The cost of access to any network could possibly be reduced by restricting usage to certain times. For example, receiving time might be limited to off-peak hours and to weekends to minimize impact on switching and transmission facilities. For services such as Green Thumb, any time-based restrictions would considerably reduce usefulness of the service; other networking considerations would need to be implemented to improve service.

In the future there could be more interaction between user and the data bank (e.g., electronic fund transfer, games, home computers, etc.); more information could be transmitted, and over a greater distance. Wider-bandwidth channels would be required to handle the increased data rate and to reduce delivery delay. Such systems are more suited to packet-switched networks where wide bandwidths can be allocated on an as needed basis.

5.6 Issues and Problems Remaining

In this section we have only touched on some of the technical issues concerning information systems and the problems they may introduce when implemented using public networks. There are of course many issues remaining and several questions to be resolved. Analyses which appear important at this time are outlined below:

1. Examine the effects of using the local loops as access to long haul networks furnished by specialized (data) common carriers.

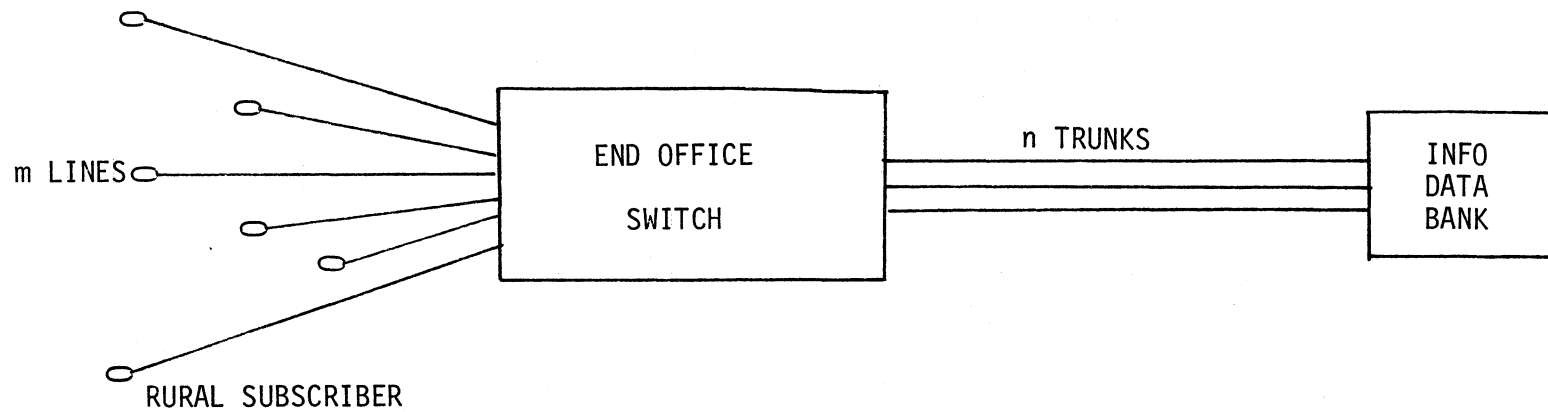

112

Figure 24. Local switching for multiple subscribers accessing a single data bank.

2. Establish a realistic scenario with m users and n trunks to the data bank. Based on percentage of simultaneous users, evaluate impact on switching capacity and probability of blocking. (See Figure 24.)
3. Evaluate delays on a mean time basis when blocking occurs at the switch due to equipment limitations.
4. Determine access time for new digital switches, common channel signaling, and faster switching times.
5. Investigate impact of billing for shorter holding times when high-speed switches become available.
6. Study advantages and disadvantages of new information systems under development. For example, a hybrid system which combines the broadcast system with a dialog (interactive) system.

6. ECONOMIC CONSIDERATIONS: COSTS TO INDUSTRY AND USERS

The development of cost models for VIDEOTEX services is beyond the scope of this report. The following summary discussion, however, highlights some of those areas anticipated to involve primary expenditures, and presents such preliminary cost information and estimates as identified in the open literature.

6.1. Broadcast Services

The U.S. has--as yet--little experience with either broadcast or interactive systems providing highly innovative services to the home subscriber. The British experience with the Ceefax and Oracle services represents the longest term offering of broadcast services, and therefore should logically provide the most empirical data base for cost analysis. Cost breakdown for these systems, however, may be quite difficult (particularly in extrapolation to the U.S. economy, due to the special relationships between the British Broadcasting Company, the British Post Office and the federal government). In the U.S., the major television broadcast companies are of course independent of one another, of the government, and of the information data handlers and providers.

Some detailed studies were made in the U.S. as early as 1975. One such study (Spongberg, 1975), prepared for the Office of Telecommunications (predecessor agency to NTIA) gives some measure of VIDEOTEX systems cost to the television industry, the data bank managers, information providers, and, finally, to the user. The study includes a survey, prepared by the Industrial Economics Division of the Denver Research Institute on a number of ancillary services for "add-ons" to

standard TV broadcast programming. Included in the study was a look at the United Kingdom's Ceefax and Oracle systems. Tables 16 and 17, reproduced from the Spongberg study, give estimates (in 1975 dollars) for added transmitter and receiver cost required for VIDEOTEX-type systems. It is to be noted, in reference to these tables, that Ceefax and Oracle are the only systems which are discussed elsewhere in this present report. The other systems, as indicated, either were not developed beyond early stages or were conceived as limited-service offerings. A broader data base for cost estimates should become available in the 1981 time frame as manufacturers gear up to produce adapters and receivers.

Receiver (i.e., user terminal) costs as compiled by Spongberg are itemized in Tables 16 and 17. Those for Ceefax/Oracle are probably indicative of what would be required for a typical broadcast service today, when corrected to present day prices. Inflation may have little impact on the cost of electronics. Costs of electronic components over the past 5 years was tabulated by the Council on Wage and Price Stability (COWPS) for a variety of electronic components and assembled systems. They have shown that there have been relatively small price changes (and these are usually lower) for the 5-year period for such electronic devices and components as TV receivers, analog devices, digital memory devices, digital integrated circuits, and digital-to-analog interfaces. Recent pronouncements in Electronic News and other trade magazines indicate that the trend is still holding for the reduction of prices, including reduced costs for microprocessors, ROMS and RAMS, and numbers of other electronic components and equipments.

It is to be noted that the tabulated costs of Table 17 for "signal originator equipment" (i.e., that required for the television transmitter station) include interfaces, data generators, etc., but do not reflect costs of data bank facilities. From the Ceefax-Oracle figure of Table 17 for add-on transmitter equipment, the VIDEOTEX entrepreneur would need to invest on the order of \$120,000 per television station (in the 1980 time frame) to provide nominal facilities. Thus in a market area having five stations, each equipped for VIDEOTEX transmission, the capital investment (exclusive of maintenance and operational costs) may exceed an average of \$600,000 per market. Based on the 100 major U.S. markets, initial investments could thus readily exceed \$60 million, not taking into account any of the smaller markets. These estimates address only those costs incurred by broadcast stations in equipping themselves for local VIDEOTEX broadcasting. The Spongberg study comes up with a figure of \$1.5-3 million (in 1975 dollars) per network to provide nationwide transmission facilities. For the three major commercial networks plus the Public Broadcasting net, this would total a \$6-12 million investment.

Table 16. Added Cost/Price^(1,2) for Data/Caption Systems
(after Spongberg, 1975)

<u>Subsystems</u>	<u>Systems</u>			
	<u>NBS TvTime</u>	<u>HRI Add-On</u>	<u>Teletext (Ceefax/Oracle)</u>	<u>RCA Homefax</u>
<u>New Receiver Design</u>				
Data Decoder	\$ 5- 10	\$ 5- 10	\$ 5- 10	N.A.(3)
Character Storage	\$ 2- 3	\$ 2- 3	\$ 5	N.A.
Character Generator	\$ 3- 4	\$ 3- 4	(4)	N.A.
Display System	\$ 2- 3	\$ 2- 3	\$ 45	N.A.
Total Manu- facturing Costs	\$12- 20	\$12- 20	\$ 55- 60	\$ 50-100
Selling Price-Retail	\$30- 50	\$30- 50	\$140-150	\$125-250
<u>External Add-On Equipment</u>				
(for existing in- operation receivers)				
Selling Price-Retail	\$40- 60	\$40- 60	\$150-160	\$135-260
Installation Cost	\$15- 50	\$15- 50	\$ 15- 50	\$ 15- 50
Total Add-On Costs	\$55-110	\$55-110	\$165-210	\$150-310

Notes:

- (1) Normal mark-ups were used. However, nonrecurring manufacturing costs will be higher because of the specialness of such products.
- (2) The table represents 1975 costs. 1980 costs may be considered as close to double, based on the inflationary expense over the past five years.
- (3) Costs not available from manufacturer.
- (4) Costs included in character storage estimate.

Table 17. Ancillary information systems. (After Spongberg, 1975).

SYSTEMS CHARACTERISTICS	NBS TVTIME	HAZELTIME (HRI)	RCA HOMEFAX	CEEFAX/ORACLE	DATA-DOT
Purpose, Function, Application	Time, Frequency Information; Captions	Captions for Deaf, Subtitles, Copyrighting	Home Facsimile	"Pages" of Information on Demand	Data Channel from Studio to Home
Audience(s); User(s) ⁽¹⁾	Mass; Special; TV Industry	Mass; Special; TV Industry	Mass; Special	Mass; Special	Mass; Special
Development Stage	Pilot Testing	Pilot Testing	Suspended	Pilot Testing	Suspended
Transmission Technique	Digital, VBI Line 21	Digital, 2.5MHz Subcarrier	Analog, VBI	Digital, VBI	Digital, Visible in Video
Specifications <ul style="list-style-type: none"> • Information Rate • Data Rate (bps) • Modulation • Degradation/Interference <ul style="list-style-type: none"> • Sound • Picture • Others 	600 word/min. 0.78 k NRZ	.30 sec/page 21.6 k Biphase	600 line/hr. Analog ---	.24 sec/page 36.0 k NRZ/Biphase ⁽²⁾	60 word/min. 60 Digital, On-Off
Affects on Competing Systems	May Restrict Use of Line 21	May Restrict Use of 2.5MHz	May Restrict Use of VBI	May Restrict Use of VBI	None
Receiver Additions (Reference Components List) <ul style="list-style-type: none"> • New Design <ul style="list-style-type: none"> • Added Costs • Added Price • Add-On <ul style="list-style-type: none"> • Total Price⁽³⁾ 	1,2,3,16 \$12-20 \$30-50 \$55-110	1,2,3,4,5,6,16 \$12-20 \$30-50 \$55-110	1,2,3,7,12,14, 15,16,17,18 \$50-100 \$125-250 \$150-310	1,2,3,7,8,10, 11,13 \$55-60 \$140-150 \$165-210	None N.A. \$250+
Signal Originator ⁽⁴⁾ Equipment Needed Costs: <ul style="list-style-type: none">• Capital• Maintenance⁽⁵⁾• Leasing	Encoder, Inserter \$3,000 \$300 ---	Encoder, Inserter \$3,000 \$300 ---	Timer, Reader, Code Generator, Multiplexer \$50,000 \$5,000 ---	Interface, Data Xmt, Inserter, Other \$60-120,000 \$6-12,000 ---	Inserter, Other \$10,000 \$1,000 ---
Related FCC References	RM-2108	None	None	None	RM-2473

COMPONENTS LIST AND NOTES FOR TABLE

Number	Component	Number	Component
1	Data Decoder	10	Sync Separator
2	Memory	11	Video Mixer
3	Character Generator	12	Video Amplifier
4	Band Pass Filter	13	UHF Modulator
5	Phase Detector	14	Horizontal Deflection Generator
6	Post Detection Filter	15	Horizontal Deflection Yoke
7	I-f Tuner	16	Display Converter
8	I-f Detector	17	Keyboard Terminal
9	R-f Detector	18	Others

Receiver modification and other (initial) user costs for a one-million subscriber system could bring the total overall costs to approximately a half billion dollars assuming no inflation increase over 1975 quoted prices.

Capital costs of system (100 markets)	\$150 million
User installation costs (1,000,000 subscribers)	\$300 million
R&D, administrative, advertising, and related costs	\$ 50 million
	<hr/>
	\$500 million

The costs for modified TV receivers may also be expected to decrease markedly with large demand and the resultant lower unit costs for decoder chips and memory. This may be true particularly for original equipment. On the other hand, the rapid advances in memory technology, resulting in higher and higher storage capacity, will probably suggest to the manufacturers and system developers more innovative and more flexible home (and business) terminals. These will in turn need additional memory and greater microprocessor capability for the more sophisticated and expensive home TV decoder/encoder modules.

An educated guess at the cost of TV receiver modification (including the decoder) comes from CBS and KSL-TV officials (Boulder Daily Camera, 1979) in reference to the future of their experimental broadcast services "...in mass production, it might add \$25 to \$50 to the cost of a new set. An adapter for sets already in existence would be more expensive perhaps \$100 to \$150..." They indicate that this is indeed a guess, since design has not been finalized and undoubtedly will not be until at least preliminary standards are developed, hopefully as a result of the CBS tests (see Sections 2.6 and 3. of this report).

Since no business organization would be prepared to lay out such large capital investments without knowing from whence the money plus a proper profit will be recouped, VIDEOTEX companies will wish to carefully investigate the markets from which such dollars can be derived. Sources for return may include:

- . Information providers, e.g., social, economic, medical, educational, political sources.
- . Fees for service to user.
- . Federal subsidies for national, state or local public service reports.

Assuming that broadcast VIDEOTEX becomes widely used, it may be expected that organizations such as the National Weather Service and various state and local social service agencies may use the VIDEOTEX system for rapid dissemination of

important information needed by the general public. To accept such services (beyond such broadcast time that a particular operator or TV station could afford to donate as "public service" time), systems operators would charge fees commensurate with the length of time of broadcast or on some other agreed upon basis.

The vending of products or services via the VIDEOTEX media may still be a big puzzle in the minds of market research organizations. It is one thing to publish and present airline or ship schedules and fees, etc. It is yet another to sell automobiles or clothes or food via the limited frame-by-frame format of the typical VIDEOTEX system. However, it may turn out that British and European experience are proving the appeal of such advertising "uncluttered" by other programming for catching and holding the attention of the serious shopper--particularly the one who must now establish a choice among an ever-growing number of alternative offerings.

User service fees could be collected by licensing of the subscriber or by charging for leasing rights on a monthly basis. Cable Television operators in the U.S. already charge fees to cover cable installation and for the monthly use of the "little black box" attached to the customers receiver, which makes it possible to receive special programs. In the case of hotels and commercial buildings, the TV receivers themselves are frequently also leased.

6.2. Interactive Services

Interactive VIDEOTEX services may incorporate the facilities, services, or products of a number of groups:

- . The common carrier network;
- . Computer and data processing industries;
- . Information providers:
 - Public service,
 - Newspapers, books, magazines, advertisers,
 - Educational organizations;
- . Customer service and maintenance services;
- . Manufacturers and providers of equipment;
- . CATV (for certain types of services);
- . Private or specialized data carriers; and
- . The broadcasters.

It is recognized that the initial outlay for interactive VIDEOTEX systems may come relatively high. Although the British and the European experiences with PRESTEL-like systems has made some economic data available (see following sub-section), it is quite likely that system architectures and the design of keypads, storage elements, etc. will not be readily adaptable to U.S. needs on a one-to-one basis. A generalized breakdown of network costs is depicted in Figure 25.

6.2.1. Prestel Capital Investment Costs

Reports in various trade journals and newspapers (Arnold, 1976; Bright, 1979) have suggested that installation of the British Prestel system, providing for wide distribution of services, is likely to be a very expensive undertaking. Expenditures for 1979 were budgeted at \$60 million. This budget had been largely spent (about \$50 million) in 1979 with only a portion of the planned 25 data centers installed.

Since a detailed cost breakdown is not available, it is not known how much of this expenditure was the result of unanticipated, nonrecurring administrative and design costs and how much was actually incurred per data center installation. Let us therefore take a look at capital investment costs predicated upon the earlier British estimates, rather than attempting to out-guess an itemization of the still on-going first phase of actual installation. Even if this prediction proves to be optimistic for the current, initial British experience, it may nonetheless be realistic for the next generation of installation as learning curve and economy of volume factors become evident. Based on a \$50 million expenditure for data centers and network interfaces for 25 centers (estimating that at least \$10 million was expended in R&D, administrative, and other start-up costs),

$$\text{cost per center (1979)} = \frac{\$50 \times 10^6}{25} \quad \$2 \text{ million.}$$

Early British estimates concluded that each data center would provide coverage for about 40,000 subscribers in metropolitan communities. This model assumed that the typical user would have needs no greater than those of the average residential subscriber.

Estimates of capacity requirements for medium-size regional data centers range from a total of 100 to 1000 (estimated average of 400) customer-access data ports. These estimates assume an average of:

- . 100 home TV terminals/port
- . 10 office terminals/port.

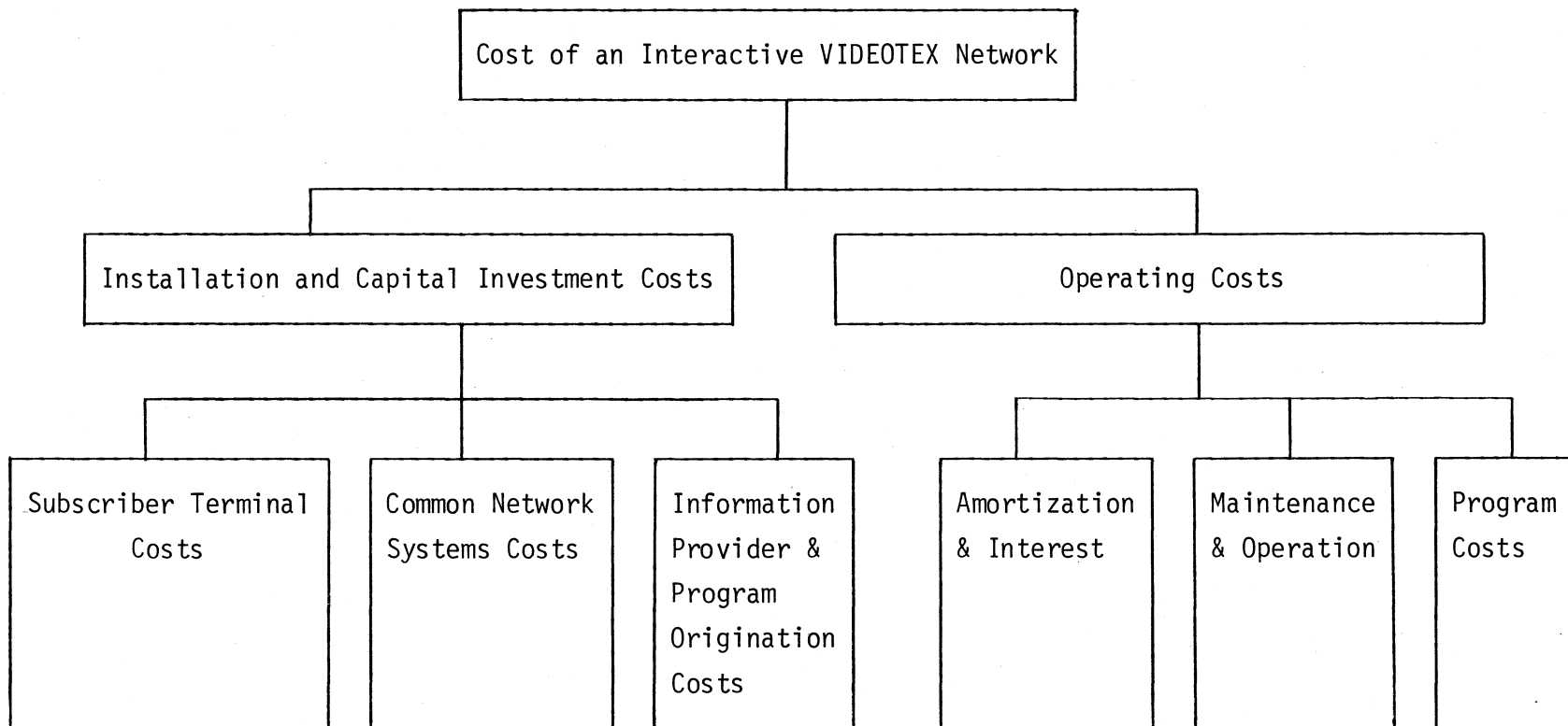

Figure 25. Schematic: Cost Breakdown of an Interactive VIDEOTEX Network.

It is to be noted that, for major business installations, it is possible that a port could be occupied 100% of the time by a single terminal. It is apparent that the above estimates are based upon small business offices, a prime potential market for new services.

6.2.2. Systems Costs for the U.S.

The previously discussed British cost estimates for the Prestel system may or may not prove to be realistic, but they represent an analysis based on the most empirical experience of any nation thus far and are used here in a broad-brush extrapolation to the American market.

Since the home TV receiver is planned as the user terminal for most proposed interactive VIDEOTEX systems, initial installation of those systems can be expected in those geographical areas with a high density of "TV families" - as will also be the case for broadcast services. The television industry has catalogued the continental United States into 100 major TV markets (50 of which are designated prime, or maximum density, markets). A TV market, in this sense, is typically a highly populated metropolitan area served by two or more broadcast stations situated within the "market region."

Using the British Prestel estimate of \$2 million per regional data center installation, a bare minimum of \$200 million would be required to introduce service into these 100 major U.S. markets. ("A bare minimum" because (1) a single data center will be capable of servicing only a small fraction of any one of our largest cities and, (2) even in a lesser metropolitan market area served by only two television stations, operation of a single data center - beyond the initial period of market evaluation - would imply cooperative use by the stations--a rather unlikely assumption considering the competition among our commercial networks.) These estimates do not address costs of nationwide networking. Additional costs of establishing data centers, beyond those of equipment purchase and installation, may include new physical plant requirements in order to house and operate data banks.

Capital investment required to set up a VIDEOTEX network also includes costs for any specialized trunking and switching facilities--independent of the existing telephone system--that may be necessary to provide distribution of data among regional centers or from a central, national node to regional offices. Such specialized facilities may be packet-switched data networks, high capacity microwave or optical fiber links, CATV, AM or FM radio, or satellite relay. (With the

sole exception of AM radio, all of these transmission media are being employed by one or more experimental systems, in the U.S. or elsewhere, for trunking and/or distribution directly to the subscriber. See Section 2.6 of this report.)

Table 18 shows a breakdown of estimated costs for equipping and operating one regional VIDEOTEX data center for a hypothetical market area of 750,000 potential subscribers. The Prestel figure of \$2 million capital investment per data center is the basis for calculation, as is the British estimate of 100 subscribers per data port. Annualized operational costs are estimated to equal the total of depreciation and interest, which are based on nominal percentages. It is interesting to note the marked decrease in cost of service per subscriber as the market penetration approaches the 40,000 subscriber volume, which the British estimated to constitute their typical market for coverage by a single metropolitan data center.

There may be system-related growth costs which will increase capital investments by some significant amount, for example as a result of increased number of computer outlets or ports. These further hardware costs, primarily in added numbers of modems, may be a significant cost factor for smaller computers, but may be only marginally significant for larger computer systems. For this example, local data processors and the fan-out of ports at such data centers will be considered as only a small fraction of the total cost of a major (regional) computer center. Therefore, the added costs for additional terminal ports has been neglected in the previous calculations. It would need to be taken into account for a carefully planned, detailed cost analysis.

Of more significance is the breakpoint in terms of numbers of subscribers that will be needed to meet the objectives of reasonable annualized costs per subscriber. It becomes necessary to estimate the number of potential customers for a market region. In a metropolitan area of 750,000 TV homes, a 1.0% penetration--which may be somewhat pessimistic for the initial few years--will provide 7500 VIDEOTEX customers. This would (see Table 18) amount to system costs per subscriber of about \$160/year. These are systems costs only and do not include subscriber use costs (charges per page), economic factors which would affect any rapid growth in numbers of subscribers. Aiming toward a more substantially sized market, such as a 5% penetration, would create a potential audience of almost 40,000 homes per regional center, providing a real incentive to advertisers. With systems costs per customer down to only \$30 per year, the system operator should be in a more viable business position. Assuming this relatively modest 5% penetration of only the 50 prime U.S. markets results in a total of two million homes equipped with interactive VIDEOTEX receivers--a substantial consumer audience.

Table 18. Interactive VIDEOTEX Systems Cost for a Regional Data Center.

CAPITAL INVESTMENT (1)				ANNUALIZED COSTS			
No. of Ports per Regional center	Household Penetration (% of total regional market)	No. of Subscribers	Cost per Subscriber (assuming 100 Subscribers per Port)	Depreciation of Capital Investment at 20% (per Subscriber)	Interest on Equipment Purchase at 10% (per Subscriber)	Operational Costs (per Subscriber)	Total Costs per Subscriber (exclusive of per page charges)
10	0.2	1000	\$2000	\$400	\$200	\$600	\$1200
50	0.7	5000	400	80	40	120	240
75	1.0	7500	270	54	27	81	162
100	1.3	10,000	200	40	20	60	120
200	2.7	20,000	100	20	10	30	60
400(2)	5.4	40,000	50	10	5	15	30
750	10	75,000	27	5.40	2.70	8	16
1000	13	100,000	20	4	2	6	12

(1) Based upon a metropolitan area of 750,000 TV homes and using the British estimate of \$2 million/Prestel regional data center installation.

(2) This is the British estimate for mature systems average coverage for a major metropolitan area. The range of their design estimates is from 100 to 1000 ports.

This section has dealt with rather tenuous financial data and some speculation with regard to the overall costs for establishing interactive VIDEOTEX systems in the United States. The discussion has perhaps served to illustrate the need for development of a comprehensive cost model to better define both what a system will cost and what the consumer may be expected to pay for new information services. Both are important parameters in future considerations of government-provided services such as those of Project Green Thumb. If the several on-going and proposed U.S. field tests of commercial systems confirm both the technical feasibility and public acceptability claimed by overseas VIDEOTEX proponents, American entrepreneurs will soon face critical decisions in pricing of the new services. A primary trade-off will involve determination of user charges that will attract a mass market while at the same time providing adequate cash flow to help amortize heavy investments over the first few years of building that market.

7. SUMMARY REMARKS

Information distribution services which are now beginning to be offered throughout the world provide, for the user, intimate interactions with significantly large and varied information stores. For some such systems, the size of the data base and variety of consumer services may be limited only by practical and economic considerations and not by any technological restrictions. Several representative new services have been introduced within this report. Attempts have been made to identify the telecommunication systems, some simplex broadcast and some duplex interactive, used for their distribution. Several of these systems and services are presently being employed in Europe and Japan, but have not as yet been introduced to any significant extent within the borders of the United States. There has, by comparison, been a more active involvement on the part of Canada, e.g., their innovative Telidon system and Project Ida with its broad base of consumer services.

It is not clear why there has not been an aggressive development and fielding of such systems and services within the United States. As noted in Appendix A of this report, various national Administrations (particularly those of the United Kingdom, Japan, and France) have worked hand-in-hand with private industry to both develop and offer these services to the public--and sell or lease the resultant expertise and hardware; e.g., the U.S. import of Prestel, and Telidon.

Some factors influencing the more gradual U.S. approach may be the lack of clear market indicators and the high costs of start-up. It is quite evident, as

the U.K. is finding out in implementing their Prestel interactive system (See Sections 2 and 6), that start-up costs for nationwide distribution systems using switched networks such as the telephone nets are very high indeed. There is understandable hesitation on the part of private entrepreneurs in considering investment on the order of hundreds of millions of dollars (as indicated by the present U.K. experience) until a viable commercial market is more clearly identified.

Field trials such as the U.S. Dow Jones/Apple experiment exemplify far less expensive (although certainly not cheap) ways of testing a service; use an existing, specialized data base and associated computer; employ an efficient mix of available transmission media; and try it out on a select, limited audience. Conceptually, the government-sponsored Project Green Thumb represents a not dissimilar effort to apply existing and available technology to disseminate existing and available information to individuals who need it.

Videotex services are likely to present economic problems to the TV broadcast industry. Commercial U.S. television is supported primarily through advertising revenues. Some portion of revenue comes via Subscription TV - mainly cable. Broadcasters and TV advertisers can find themselves in competition with the VIDEOTEX home information services since, in effect, both the broadcast and interactive services have the potential of preempting the use of the TV receiver at any time, even during prime time, at the customer's desire. Broadcasters are in continuous competition with one another for their share of TV viewing. As VIDEOTEX services are extended (Broadcasting, 1979) to video fax, banking services, and special feature presentations, this could mean that, to them, use of the television set as an entertainment source could be denied to other members of the family for long periods of time; perhaps for hours. The network media providers and advertisers will need to assess the possible effects of such services upon the size of their viewer audiences and the effects on revenues from advertising. The fact that many homes have more than one TV receiver, permitting the viewers to divide their attention between regular broadcast television and VIDEOTEX may be of small consolation to the advertisers and the broadcasters who want to make sure that the adult viewers are watching the advertising.

As discussed in Section 3, formulation of standards faces some strong issues, but is being addressed both domestically and internationally. Domestically, results of the CBS/EIA broadcast tests are now being evaluated by a diverse number of interests. Internationally, the CCITT Study Group I has established a VIDEOTEX Party to attempt a "reasonable international standard-uniform but flexible-in the areas of coding, display standards, and operating procedures",

With the almost exploding number of VIDEOTEX systems in Europe and Japan and, most recently, in the Western Hemisphere, it has become obvious that many of these systems are not compatible either in the electronic sense or in the protocols employed. Standards have been shown to be necessary to establish character code sets common (ideally) to all systems. Standards have also become necessary to provide acceptable handshaking procedures and other command and control functions necessary for the communication process. Some of the objectives for the CCITT and ISO standards groups are as follows:

- . Compatibility of consumer terminal equipment for interactive and broadcast VIDEOTEX.
- . Acceptable quality of reproduction (display).
- . Economical purchase and installation.
- . International network capabilities: intelligent gateways (protocols, easily interchangeable codes, data packages, software).
- . Interconnectability features.
- . Extension of information services to greater utilization by users.
- . Acceptable frame formats.
- . 625/525-raster-line conversion.
- . Terminal identification for billing purposes.

The British Post Office offered as a primary motivation for the development of the interactive Prestel system the promotion of increased use of the nationwide facilities of the U.K. telephone network. In the U.S., potential ramifications (as discussed in Sections 4 and 5) of large scale implementation include both economic and technological factors (which almost inevitably result in long term economic effects). Economic considerations, as discussed in Section 6, include the fact that in the U.K. all local telephone calls are tarified on a charge-per-unit-time basis (message rate). In comparison, in many local areas in the U.S., a flat charge/month is charged for local use - no matter how long the phone is used.

Near term technological problems may be of considerable concern--to the consumer, to the system operator, and to the switched telephone network. Based on the preliminary analysis of Section 5, it appears that implementation of information systems using the public switched telephone network could cause blocking due to congestion in the switch or congestion at the computer port if usage occurs during peak busy hours of the day. The most severe switch element affected is the control element. The effect on the switch could be disproportionately greater than the increased traffic would intuitively suggest. In some cases, blocking can be alleviated only by expanded switching capacity at the local switching office. In cases of congestion at the computer terminal ports, either an increase in the number of ports or some form of queueing and signaling to the customer may be required.

When interactive systems are implemented in a local area (such as plans for Green Thumb), serious consideration should be given to the number of trunks employed between the end office switch and the central data bank. This is important because one expects most users of the system would be requesting access at nearly the same time (e.g., early morning, noon, and evening for the agribusiness-oriented Green Thumb service, and evenings for Prestel-like general information systems). This could cause considerable blocking when trunk groups are limited. In the case of the Green Thumb preliminary analysis, increasing the number of trunks from 7 to 14 decreases the percentage of blocked calls by almost an order of magnitude for 100 subscribers making one call/hour.

A detailed study is required in order to determine the full impact on the telephone network in the local exchange area and on the performance of Prestel or Green Thumb type systems. Traffic data statistics and models are required in order to evaluate the blocking probabilities due to congestion at the switching matrix and the control elements. This is particularly important in rural areas (often having older switching plants), where implementation of the Green Thumb system is proposed, but may also be of significance in some metropolitan areas.

VIDEOTEK services will require careful consideration of other local and nationwide information dissemination systems. Private firms (e.g., see The Source, Section 2.6 of this report) plan various offerings of electronic mail in conjunction with a broad variety of other VIDEOTEK services. The last few years have seen a proliferation of message and "small parcel" services. All such services offer a

common commodity: fast delivery. Some use the telephone or other telecommunication networks and services, are relatively economical; others utilize delivery of hard copy by airplane and courier service and are highly labor intensive. Cost and value-added comparisons of the various service offerings will be required to determine the most economical service for the customer.

The spiraling costs of information distribution to the consumer is evident in the almost exponentially growing costs for the production and delivery of magazines, somewhat less so in the case of newspapers - a differential perhaps partially due to the largely local distribution of newspapers. Virtually all U.S. newspapers employ state-of-the-art VIDEOTEX-like technology in their news gathering, network distribution, and editing. The next logical step will be to determine whether VIDEOTEX services and magazines distributed via VIDEOTEX directly to the consumer will be an economic and satisfactory supplement or alternative for the subscriber. It is possible that experiments such as that by Knight-Ridder (see Section 2.6) may reflect such a trend. One question would be whether such systems will offer future compatibility with delivery of a broader variety of services--conceivably electronic mail.

Numerous pilot programs have been proposed and several are underway; the aggregate technological, sociological, and economic experience from these demonstrations and experiments should prove invaluable. Unfortunately, no single organization has been identified with the catalytic role of analyzing this overall experience. In summary, the following factors are seen as important in the early and efficient development of VIDEOTEX systems in the United States:

- . Determination and resolution of standards, both nationally and internationally.
- . Thorough analysis of potential social problems, including those of privacy.
- . Resolution of potential policy issues such as regulation, if any, of who may provide--and charge for--what type of services. . Intensive economic analysis, focused on initial systems' start-up costs, utilizing all available data from existing (and competitive) foreign systems.
- . Network planning to provide the necessary interfaces and interconnects for Videotex systems which are not directly compatible.

8. ACKNOWLEDGMENTS

We wish to acknowledge the participation by Kathleen Criner, Office of Telecommunications Applications, NTIA, Washington, DC, in helping expand the scope of this report to meet the special needs of NTIA. We thank, also, Mr. Joseph Hull, Associate Director, Institute for Telecommunication Sciences, Boulder, CO, for his guidance and personal interest in helping us focus on relevant questions of standards and social issues which may result from broad applications of VIDEOTEX services. We also extend our thanks to Dale Hatfield, Associate Administrator for the Office of Policy Analysis and Development (OPAD), John Lyons and Gene Ax, also of OPAD, for their helpful and constructive criticism in the preparation of this report. And our appreciation to our able secretary, Minnie Brooks, who made our task easier through her personal diligence, attention to detail, and editorial assistance.

9. REFERENCES

- Arnold, W. F. (1976), Britain to get wired city-via telephone, *Electronics* March 4.
- Barbetta, F. (1979), CBS joins EIA in test of foreign TV data system, *Electronic News*, Jan. 29.
- Beran, D. W., K. D. Hadeen, W. H. Klein, C. G. Little, H. Lufkin, and H. W. Yates (1978), Program development plan for a Prototype Regional Observing and Forecasting Service (PROFS), U.S. Dept. of Commerce, NOAA/ERL, Boulder, CO 80303, Sept.
- Bluestein, L., M. Crystal, A. Pierce, B. Schuttler, and L. Smith (1972), Telecommunication services for Flower Mound New Town, TR72-471.3, GTE Laboratories, Inc., Waltham, MA 02154, July.
- Boulder Daily Camera (1979), Knight-Ridder to test Viewtron, *Daily Camera*, Boulder, CO, Wed., April 18, p. 28.
- Bown, H. G., C. D. O'Brien, W. Sawchuk, and J. R. Storey (1978), A general description of Telidon: A Canadian proposal for VIDEOTEX systems, CRC Tech. Note No. 697-E, Dept. of Communications, Ottawa, Canada, December.
- Bright, R. D. (1979), Britain's Prestel goes international, *Telephone Engineer and Management*, Feb. 1.
- Broadcasting (1979), State of the fifth estate: Perils and prospects over the electronic horizon, *Broadcasting*, Jan. 1, pp. 42-50.

- CCITT (1978), Contribution #77 to CCITT Study Group VIII, Nov. 2.
- CCITT (1979a), Communications, COM-VIII, No. 102-E, Meeting Report (Bern, #10-15), Jan.
- CCITT (1979b), Communications, COM-I, No. 152E, COM-VIII, No. 93E, Jan.
- CCITT (1979c), Communications, COM-I, No. 185-E, Study Group I, June 20.
- Cornell, R. G., and L. D. Whitehead (1979), A centralized approach to new network services, ICC'79, Proceedings, pp. 3.3.1-3.3.7.
- Halsey, J. R., L. E. Hardy, and L. F. Powning (1979), Public data networks: Their evolution, interfaces and status, IBM Systems Journal 18, No. 2. pp. 223-243.
- HI-OVIS (1976), Demonstration of the experiment of HI-OVIS prototype, Visual information System Development Association, Higashi Ikama, New Town, Nara Prefecture, Japan, November.
- HI-OVIS (1979), Review: HI-OVIS successful in early tests, MSN, August.
- Lyman, E. R. (1978), PLATO highlights, University of Illinois/CERL, Urbana, IL, March.
- Nacon, R. J., and D. P. Worrall (1979), New custom calling services, ICC'79 Proceedings.
- The Washington Post (1979), Home-cable TV link tested on financial market information, Thursday, July 5.
- Project Ida, Press Release and Brochure (1979), Manitoba Telephone System, Winnipeg, Manitoba, Canada, July 20.
- Spongberg, R. C. (1975), Ancillary signals for television: Innovations and implications, Executive Summary and Final Report, Research Institute, University of Denver, September.
- Williams, J. G., W. T. Hartwell, and G. D. Bergland (1979), Basic capabilities and future possibilities of centralized network services, ICC'79 Proceedings, pp. 3.3.1-3..2.5.
- Woolfe, R., and H. B. Gaffner (1978), Viewdata and its potential impact in the USA: Interim Report-The U.K. experience, August; Final Report/Vol. I, The U.K. experience, Oct.; Final Report/Vol. II, The U.S. potential, Nov.; Executive Summary, Nov., LINK, New York, NY 10003, in conjunction with Butler Cox and Partners, Ltd., London EC1, England.

APPENDIX A

HOME INFORMATION SYSTEMS:
VIEWDATA AND TELETEXT

Bibliography
Semi-Annotated

Prepared by Martha Johnson-Hall
for Kathleen Criner, Program Manager
Home Information Systems Program
National Telecommunications and Information Administration

BOOKS

*Teletext and Viewdata. Luton, England: Mackintosh
Publications Limited, 1977.

Reviews progress in development of teletext and
viewdata systems. Good discussion of technical
aspects and commercial characteristics of these
systems. Includes assessment of future impact
in terms of factors affecting introduction and
acceptance, market growth and international
development.

*Videotex Services; the Market Potential for Cable. Montreal:
Tamec Inc., January 1979.

Examines the potential market in the Canadian
cable TV industry for a one-way system of
videotex services supported by information
providers. Also looks at the prospects for
videotex services in U.S.

*Viewdata and Its Potential Impact in the U.S.A. 2 vols.
London: Link in association with Butler Cox and
Partners Limited, 1978. Vol 1: The UK Experience,
Vol. 2: The U.S. Potential.

Volume One provides a detailed description of Britain's
viewdata service, including system design, plans
and attitudes of parties involved, investments,
and assessments of the future market. Volume Two
discusses market research in U.S. including results
of interviews with experts in industries that will
be affected by the introduction of viewdata and with
consumers of prospective viewdata services.

*Proprietary

JOURNAL ARTICLES

A. BACKGROUND

Bailey, Allan. "What's on the Tube Tonight Dear? Everything." Maclean's, 9 January 1979, pp. 54-55.

Barouch, Karen Rubin. "Future Technology; the Threat and the Promise." The Travel Agent, August 1978, pp. 19-24.

_____. "Viewdata: How it Works in the U.K. Travel Industry." The Travel Agent, 31 August 1978, pp. 24-25.

_____. "Viewdata: Industry Suppliers Speak Out." The Travel Agent, September 1978, p. 18.

_____. "Viewdata: What U.S. Wholesalers Think." The Travel Agent, 5 October 1978, p. 26.

Bell, Daniel. "Teletext and Technology." Encounter (London), June 1977, pp. 9-29.

Briscoe, David. "Home Delivered Data at the Touch of a Button." Washington Post, 23 May 1979.

Cawkell, A.E. "Developments in Interactive On-Line Television Systems and Teletext Information Services in the Home." On-Line Review, January 1977, pp. 31-38.

Cawthorne, Nigel. "What's Next? Teletext." Video, Spring 1979.

Clark, Richard. "Videotex - an Overview of Electronic Information Services." Computer Communications, April 1979, pp. 51-55.

Haefner, K.; Mahnkopf, P.; and Teichman, H-J. "New Uses for the TV Set." Intermedia, September 1978, pp. 15-20.

Develops a broad classification system describing the range of potential services that could be offered by an expanded domestic television receiver. The nature and scope of these services, although determined by technical factors, are defined by various quantitative and qualitative factors.

Hawkes, Nigel. "Science in Europe/British May Use Telephones, TV's, to Tap Data Banks." Science, 7 July 1978, pp. 33-34.

Hirsch, Phil. "Videotex is Coming, How Far Behind is the Home Computer?" The Hirsch Report, January 1979, pp. 1-18.

- Hirsch, Phil. "Videotex/Teletext Services - Part II."
The Hirsch Report, March 1979, pp. 1-17.
- Holmes, Edith. "Viewdata, Teletext Storm Europe; Does U.S. Market Exist?" Information World, Winter 1978, p. 2.
- Holmlöv, P.G. "There's a Neighbor Typing in my Tube: Teletext in the Community" Institute for the Future Newsletter, Winter 1978-79, pp. 3-5.
- Howkins, John. "Prospects for Teletext and Viewdata."
Independent Broadcasting.
- Lipoff, Stuart J. "Mass Market Potential for Home Terminals."
Paper presented at the IEEE Fall Conference on Consumer Electronics, Chicago, 6-7 November 1978.
- Logue, Timothy J. "Teletext: Toward an Information Utility?"
Master's thesis, American University, 1977.
- Madsen, Arch L. "The Promise of Teletext." Speech given to National Association of Broadcasters, Washington, D.C.
- Malik, Rex. "The TV as a Terminal." Datamation, 2 March 1978, pp. 213-215.
- Ryberg, Judy. "Industry Reluctant to Develop Teletext."
Information World (Special Supplement), April/May 1979, p. 13.
- Saxton, W.A., and Edwards, Morris. "Datacommunications Directions; Information Retrieval From the Home."
Infosystems, May 1978, pp. 88-89.
- Scott, David. "Teletext/Viewdata Converts Your TV Set into an Instant Information Service." Popular Science, May 1978, pp. 108-111.
- "Teletext, Viewdata TV Information System Eyed by U.S. Broadcasters, Cable, Set Manufacturers." Television/Radio Age, 25 September 1978, p. 38.
- Wilkinson, Max. "Viewdata: the Friendly Living Room Computer." Financial Times (London), 1 March 1978.
- Wood, C.B.B. "Broadcasting the Written Word." E.B.U. Review, July 1977, pp. 16-18.

B. COMPUTING APPLICATIONS

- Abrams, Earl B. "Teletext, Viewdata Developers Converting Home TV Sets into Computer Terminals." Television/Radio Age International, 29 January 1979, pp. A41-A45.

Baker, Rufus; Gross, Steve; Hershberger, Steven; and Crudele, John. "Personal Computers - Building Block or Jelly Bean?" Electronic News, 2 April 1979, p. 46.

Describes ways in which viewdata and teletext systems might complement the operations of personal computers and discusses possibilities for integrated home information systems.

d'Agapeyeff, Alex. "Telesoftware Concept May Act as Catalyst for Viewdata." Direct Marketing, March 1979, p. 68.

*Easterbrook, William D. "Computer Industry; Viewdata - Mass Computing in Embryo?" Kidder, Peabody and Co., Incorporated, 13 April 1978.

Hedger, J. "Telesoftware; Home Computing via Teletext." Wireless World, November 1978, pp. 61-64.

Article about a scheme for broadcasting computer programs, using a teletext service, into micro-computers built into the teletext decoders of tv receivers.

Leavitt, Don. "Viewdata Expanded." Computerworld 13 November 1978, p. 1.

"Microprocessor Smartens Teletext." Electronics, 28 September 1978, p. 74.

Smith, Walton E. "The Information Utility, an Alternative to the Personal Computer." Speech presented at the Air Force Academy, Colorado Springs, Colorado, 25 January 1979.

"U.S. TV Station to Write Viewdata Software Link." Electronic News, 22 January 1979, p. 81.

C. ELECTRONIC PUBLISHING

Alhauser, John W. The Electronic Newspaper: U.S. Editors' Reactions to Teletext. Research Report No. 9. Bloomington, Indiana: Indiana University--Bloomington, February 1979.

Author briefly describes four British electronic news delivery systems. He discusses the results of a survey of U.S. newspaper editors regarding their perceptions of problems to be encountered by themselves and their readers with teletext.

Edwards, Kenneth. "The Electronic Newspaper." The Futurist, April 1978, pp. 79-84.

*Proprietary

Edwards, Kenneth. "European Electronic Newspapers Usher in New Communications Age." Direct Marketing, November 1978, pp. 134-154.

Gollin, Al. "Prestel; or the Little Black Box with a British Accent." The Bulletin of the American Society of Newspaper Editors, February 1979, pp. 14-17.

"Home TV Centers to Upset Print Media in 1990's." Editor and Publisher, 24 February 1979, p. 9.

D. NON U.S. SYSTEMS

Erikson, Arthur. "British, French in U.S. Teletext Race." Electronics, 29 March 1979, pp. 82-83.

Pye, Roger. "Focus on Europe; Information Retrieval Services." Telecommunications Policy, March 1978, pp. 73-78.

Roizen, Joseph. "The Current State of International Teletext Technology." TV Communications, July 1978, pp. 42-43.

Rosch, Gary D. "Viewdata and Teletext Systems: What the Europeans are Doing." Executive Perspective, Second Quarter 1979, p. 25.

"Vieotex: Words on the TV Screen; Viewdata, Teletext and the Rest." Intermedia, May 1979, pp. 6-53.

A state-of-the-art survey of videotex, this series of article deals mainly with Prestel, the British system of videotex, but looks at services developing in other countries as well. Excellent description of current activities and trends.

Britain

Alexander, Luke. "Is Prestel Too Expensive?" Intermedia, December 1978, pp. 7-8.

"BPO Exports Prestel." This Month in Telecommunications, October 1978, p. 3.

Byrne, John. "U.K. Launches TV Information Systems." Electronic News, 2 April 1979, p. 45.

Christie, Stephen. "CEEFAX - the BBC's Digital Data Broadcasting Service - Development and Operation." New York: British Broadcasting Corporation, U.S. Office, 1977. (Mimeographed.)

Concise, informative account of technical development of broadcast teletext system in Britain.

- Milmo, Sean. "Retailers Turn to Prestel for U.K. Viewdata Debut." Advertising Age, 23 April 1979, p. 94.
- Reid, Alex. "Prestel: A New Way of Publishing." London: British Post Office, 20 May 1978. (Mimeographed.)
- Rosch, Gary D. "New Data and Information System Set for Commercial Market Trial." Telephony, 20 March 1978.
- Rosch, Gary D. "The Technical Side of Viewdata." Telephony, 10 July 1978, p. 140.
- "Three Men on a Viewdata Bike." The Economist, 25 May 1978, pp. 70-71.
- "UKPO Launches Public 'Viewdata' Service." Telecommunication Journal, May 1978, pp. 213-214.
- "Viewdata - A Review and Bibliography" Online Review, September 1978, pp. 217-224.
- "Viewdata Systems." Financial Times (London), 9 May 1979, pp. 19-26.
- "When a Computer Bank Teams Up with a TV Set." Business Week (Industrial Edition), 19 June 1978, p. 40E.
- Williams, Ederyn. "Strengths and Weaknesses of Prestel." Computer Communications, April 1979, pp. 56-59.

Canada

- Bailey, Allan, and Collins, Anne. "Getting a Jump on the Whole Wired World." Maclean's, 25 September 1978, pp. 45-46.
- Brown, H.G.; O'Brien, C.D.; Lum, Y.F.; Sawchuk, W.; and Storey, J.R. "Canadian Videotex System." Computer Communications, April 1979, pp. 65-68.
- Brown, H.G.; O'Brien, C.D.; Sawchuk, W.; and Storey, J.R. "A General Description of Telidon: - A Canadian Proposal for Videotex Systems." Ottawa, Canada: Department of Communications/Communications Research Centre, Technical Note No. 697-E, 1978.
- "Teletext in Canada" Broadcast Communications, October 1978, p. 6.
- Wright, David. "Is There a Good Market for a Good Technology?" In Search (Canada), Winter 1979, pp. 2-16.
- Excellent description of development of Telidon system.

Finland

Jaakola, Pekka; Hirvonen, Maarit; and Baerlund, Ole.
"Telset, the Finnish Viewdata." Computer Communications,
April 1979, pp. 69-73.

France

"First Public Demonstration of the Antiope Teletext System."
E.B.U. Review-Technical Part, no. 161, February 1977,
pp. 41-42.

Guinet, Y. "New Services Offered by a Packaged - Data
Broadcasting System." E.B.U. Review - Technical Part,
no. 149, February 1975, pp. 3-10.

Defines context in which France's Antiope system was
developed. Distinguishes between the system and its
organization and the services that could be offered by
a digital broadcasting system.

Marti, Bernard. "Videotex Developments in France." Computer
Communications, April 1979, pp. 60-64.

Marti, B.; Foignet, A.; and Schwartz, C. "Problems of Choice
of a Teletext System in European Countries." Rennes
(France): Centre Commun D'Etudes de Television et
Telecommunications. (Mimeographed.)

Description of capabilities of French teletext service
with some comparison to Britain's Ceefax and Oracle
systems.

Sweden

Kvarnefalk, Gunna. "Datavision and Text TV in Sweden."
Computer Communications, April 1979, pp. 74-75.

E. POLICY AND REGULATORY ISSUES

"The Coming Merger of Broadcasters and Common Carriers???"
Electronic Mail and Message Systems, 1 August 1978,
pp. 8-11.

Grundfest, Joseph, and Baer, Walter. "Regulatory Barriers
to Home Information Services." Santa Monica, CA: The
Rand Paper Series, No. P-6106, June 1978.

Suggests some of the regulatory barriers to viewdata-like services in regard to the separation of communications from data-processing functions.

Kirchner, Jake. "Public Data Retrieval Viewed Benefit, Bother." Computerworld, 6 November 1978, p. 69.

Mahn, Terry G. "Teletext, Viewdata Vendors Face Barriers in Existing Regulations." Computer Business News, pp. 4-5.

Nyhan, Michael J.; Johansen, Robert; and Plummer, Robert. "Home Information Systems; Thoughts on the Role of Public Broadcasting." Public Telecommunications Review, May/June 1979, pp. 20-25.

Roizen, Joseph. "FCC Assesses U.S. Teletext Potential." Broadcast Communications, December 1978, pp. 52-53.

Sirbu, Marvin A., Jr. "Automating Office Communications: the Policy Dilemmas." Technology Review, October 1978, pp. 50-57.

Article introduces some of the policy issues surrounding electronic message systems, discussing these in terms of how large user firms view such services versus what individuals and small firms wish to derive from such services.

Tyler, Michael. "Videotex, Prestel and Teletext, the Economics and Politics of Some Electronic Publishing Media." Telecommunications Policy, March 1979, pp. 37-51.

Excellent introduction to most current videotex services and their implications for public policy.

"Viewdata Receives Super Shot in the Arm." Electronic Mail and Message Systems, 15 June 1978, pp. 3-5.

Wiley, Richard E., and Bartlett, John L. "New Communications Systems Promise Novel Problems for Lawyers." Legal Times, 27 November 1978, p. 13.

F. RECENT U.S. DEVELOPMENTS

Barbetta, Frank. "CBS Joins EIA in Test of Foreign TV Data System." Electronic News, 29 January 1979.

"Blue Sky Back on Horizon for Cable." Broadcasting, 28 May 1979, pp. 46-47.

"CPB, PBS Plan Teletext." Public Broadcasting Report,
11 May 1979, p. 1.

Crudele, John. "TI Tests Home Information System."
Electronic News, 6 November 1978, p. 24.

"Electronic Newspapers in Home will Shortly be a Reality."
Electronic Mail and Message Systems, 17 July 1978,
p. 6-10.

Frank, Ronald A. "Major Obstacles Block Viewdata Use in
U.S." Computerworld, January 1979, p.1.

"Future Place in U.S. Market Seen for Teletext, Videotext
Systems." Computerworld, 6 November 1978, p. 69.

"Home-Cable TV Link Tested on Financial Market Information."
Communications News, 2 July 1979, p. 15.

"Knight-Ridder, UPI Slate Home Video Info Plans." Advertising
Age, 23 April 1979, p. 2.

Loveless, Bill. "KSL-TV Fuels Teletext Interest with
Successful On-Air Tests." Broadcast Communications,
December 1978, pp. 46-50.

Outman, James. "Information Service for Cable to be Delivered
Via Satellite by Reuters." TV Communications,
1 December 1978, pp. 122-123.

Schuyten, Peter J. "Technology Turning TV Set into a
Computer." New York Times, 28 June 1979, Sec. 4, p.D2

"UPI to Have Newswire Available Via Satellite." Communications
News, 2 July 1979, p. 15.

Williams, David. "Oak, Micro TV in Talks for Teletext."
Electronic News, 13 November 1978, p. 25.

G. TECHNICAL DESCRIPTIONS

Biggs, A.J., and Barnaby, B.S. "Broadcast Data in Television."
GEC Journal of Science and Technology 41, 1974, pp. 117-124.

Fedida, S. "Optimising Viewdata." Wireless World, June 1978,
pp. 75-77.

_____. "The Viewdata Computer." Wireless World,
April 1978, pp. 44-48.

_____. "The Viewdata Computer-2." Wireless World,
May 1978, pp. 73-76.

- _____. "Viewdata: The Post Office's Textual Information and Communications System: 1-Background and Introduction." Wireless World, February 1977, pp. 32-36.
- _____. "Viewdata; 2 - Applications of the System." Wireless World March 1977, pp. 52-54.
- _____. "Viewdata; 3 - Operation of the System: Terminals and Codes." Wireless World, April 1977, pp. 65-69.
- _____. "Viewdata; 4 - The Viewdata Terminal in More Detail." Wireless World, May 1977, pp. 55-59.
- Guinet, Y. "Comparative Study of Broadcast Teletext Systems. Some Advantages of the Application of Packaged-Data Broadcasting to Teletext." E.B.U. Review-Technical Part, no. 165, October 1977, pp. 3-15.
- An analytical comparison of the French and British teletext systems, looking at their performance and the technological and economic constraints implied by each.
- Guinet, Y. "Letter to the Editor." E.B.U. Review-Technical Part, no. 168, April 1978, pp. 88-89.
- Response to Redmond and Robson letters about Guinet's "Comparative Study" article.
- Redmond, J. "Letters to the Editor." E.B.U. Review-Technical Part, no. 167, February 1978, p. 40.
- Response to Guinet's "Comparative Study" article.
- Robson, T.S. "Letters to the Editor." E.B.U. Review-Technical Part, no. 167, February 1978, pp. 40-41.
- Response to Guinet's "Comparative Study" article.
- Strangeways, Richard. "Teletext--Hardware Design Approach." Broadcasting Systems and Operation, September 1978, pp. 15-16.

APPENDIX B

International Telegraph and Telephone
Consultative Committee
(CCITT)

COM I-No. 176-E^{*}

Period 1977-1980

English only

Question: 19/I

Date: 20 June 1979

STUDY GROUP I - CONTRIBUTION No. 176
=====

SOURCE: UNITED STATES OF AMERICA

TITLE: VIDEOTEX TERMINOLOGY: PARAMETERS SUBJECT TO STANDARDIZATION

1. Introduction

- 1.1 Since the drafting of new Question 19/I for CCITT Group I in the Geneva, 8-9 May 1978 meeting, there has been an increased interest on the part of many Administrations with regard to potential VIDEOTEX Services. Some Administrations have announced that they are engaged in market trial-planning activities, and others have provided additional details of planned VIDEOTEX Services.
- 1.2 In response to CCITT requests for contributions from interested Administrations, some excellent and informative papers have been submitted that have helped the international community to better understand and discuss the VIDEOTEX issues.

*)

Contribution retardée publiée seulement dans la langue reçue (anglais), sans traductions supplémentaires, conformément, aux dispositions de la Résolution N°1, paragraphe III.4.d) adoptée par le VI^e Assemblée (1976).

Late Contribution published only in the language received (English), without further translations, in accordance with Resolution No. 1, paragraph III.4.d) VIth Plenary Assembly (1979).

Contribución retardada publicado sólo en el idioma en que se recibió (inglés), sin otras traducciones de conformidad con la Resolución N.º1, párrafo III.4.d), VI Asamblea Plenaria (1976).

1.3 At this point in the process of developing standards, it is felt that considerable time can be saved and a unification of approach to Question 19/I can be achieved, if the proper terminology can be identified that defines those parameters of a VIDEOTEX Service that are subject to standardization.

2. Scope

2.1 This Contribution is in response to the request by the Study Group I Chairman at the 10-15 January 1979 meeting in Bern, for definitions of Terminology.

2.2 Other contributions that relate to this subject are:
COM I - No. 103; COM I - No. 116; COM I - No. 124; ANNEX 2 & 3;
and COM VIII - No. 78, Annex 5.

2.3 Contributions which relate to section 4.5.2 of this Contribution are COM I - No. 122 and 123.

3. Purpose

3.1 The purpose of this contribution is to suggest a structure that will promote an effective dialog between Administrations and the CCITT, which will allow a comprehensive identification of all relevant parameters of a VIDEOTEX Service.

3.2 Due to the level of complexity of an international service like VIDEOTEX, it is recognized that the difficulty in identifying exactly which parameters need to be standardized is significant. However, it is reasonable to assume that it can and should be done now, in order to develop trial/service standards for the 1980's.

3.3 Using the structure outlined in section 4 of this Contribution as a starting point, Study Group I could apply some of its efforts to develop a well-defined list of parameters which are subject to standardization. It is expected that this will be an interactive process, as actual parameters are subjected to intense discussions and empirical studies (trials).

4. Standard Terminology

4.1 The potential standardized parameters are divided into four categories; Display Characteristics, Character Repertoire, Line Control Procedures, and End-to-End Procedures. The line entries designated with alphabetic characters are typical examples of possible parameters. See Annex I for further definitions.

- 4.1.1 It should be noted that there could be significant differences in the actual parameters chosen for terminals which only receive information versus those which are used to create new or to modify existing pages of information. However, the eventual structure should still apply.

4.2 DISPLAY CHARACTERISTICS

4.2.1 SCREEN STRUCTURE

4.2.1.1 MATRIX ORIENTED

- A. NUMBER OF SYMBOLS PER ROW
- B. NUMBER OF SYMBOL ROWS PER SCREEN

4.2.1.2 FREE-FORM ORIENTED

4.2.2 FIELD GEOMETRY

4.2.2.1 BACKGROUND MATRIX

4.2.2.2 FOREGROUND SYMBOLS

4.2.2.2.1 NON-GRAPHIC DOT MATRIX

4.2.2.2.2 MOSAIC GRAPHIC MATRIX

4.2.3 DISPLAY ATTRIBUTES

4.2.3.1 COLOR INFORMATION

4.2.3.1.1 MATRIX ORIENTED

- A. TOTAL NUMBER OF POSSIBLE COLORS
- B. NUMBER OF POSSIBLE COLORS DISPLAYED SIMULTANEOUSLY
- C. NUMBER OF POSSIBLE COLORS DISPLAYED IN A SINGLE FIELD

4.2.3.1.2 FREE-FORM ORIENTED

- A. TOTAL NUMBER OF POSSIBLE COLORS
- B. NUMBER OF POSSIBLE COLORS DISPLAYED SIMULTANEOUSLY

4.2.3.2 SPECIAL FEATURES

- 4.2.3.2.1 MOTION
- 4.2.3.2.2 FLASHING
- 4.2.3.2.3 CONCEAL
- 4.2.3.2.4 PROTECTED
- 4.2.3.2.5 SCREEN BORDER

4.2.4 OTHER ISSUES

- 4.2.4.1 AUDIO
- 4.2.4.2 PHERIPHERAL INTERFACES

4.3 CHARACTER REPERTOIRE

4.3.1 BASIC SYMBOL SET

- 4.3.1.1 ALPHANUMERICS AND SPECIAL SYMBOLS
- 4.3.1.2 GRAPHICS

4.3.2 TRANSMISSION CHARACTER SET

- 4.3.2.1 CONTROL COMMANDS
- 4.3.2.2 COLOR CODES
- 4.3.2.3 SPECIAL CONTROLS

4.3.3 DOWNLOADED SETS

4.4 LINE CONTROL PROCEDURES

4.4.1 CIRCUIT CHARACTERISTICS

- A. SPEED
- B. MODE (HALF DUPLEX/FULL DUPLEX)
- C. FACILITIES (DIAL/LEASED)
- D. SYNCHRONIZATION (ASYNCHRONOUS VS. SYNCHRONOUS - BIT, CHARACTER, OR MESSAGE)
- E. PATH (SERIAL/PARALLEL)
- F. METHOD (ANALOG/DIGITAL)
- G. TERMINAL/LINE INTERFACE

4.4.2 LINE PROTOCOL

- 4.4.2.1 CALL ESTABLISH AND TERMINATE
- 4.4.2.2 MESSAGE TRANSFER
 - A. ERROR DETECTION/CORRECTION

4.5 END-TO-END PROCEDURES AND SECURITY FUNCTIONS

4.5.1 AUTHORIZATION PROCEDURES

- 4.5.1.1 AUTOMATIC TERMINAL ANSWERBACK
- 4.5.1.2 USER IDENTIFICATION CODE
- 4.5.1.3 PASSWORD
- 4.5.1.4 ENCRYPTION

4.5.2 MESSAGE FLOW CONTROLS/ACCESS PROTOCOLS

4.5.2.1 INFORMATION FRAMES

4.5.2.1.1 OPERATIONAL COMMANDS

- 4.5.2.2 ERROR MANAGEMENT MESSAGES AND PROCEDURES
- 4.5.2.3 OTHER-SYSTEMS INTERFACE REQUIREMENTS

5. Related Issues

- 5.1 A major issue that will profoundly affect the eventual standards is the amount of "intelligence" in each terminal (ref. COM I - No. 116). For example, if a terminal were to have the ability (intelligence) to accept external commands that could cause it to alter its Basic Symbol Set prior to a data transaction, a practically infinite range of symbols (characters, etc.) could be utilized in a VIDEOTEX Service. In this case, it would be important to define a "standard" method to alter the Basic Symbol Set, but which would alleviate the necessity of "standardizing" a single unique Basic Symbol Set.
- 5.2 As previously mentioned in other contributions, the issue of the degree of compatibility required between VIDEOTEX/TELETEx/TELETEXT, etc., and the identification of responsibilities among these services that are required to effect compatibility, must be addressed and resolved.
- 5.3 As Study Group I continues to work toward an effective VIDEOTEX service definition, it will become necessary to exchange ideas with other standards groups and organizations in order to establish an acceptable set of standards. Of significant interest at this time is the work by some groups (e.g. ISO) on the ambitious task of standardizing the levels or layers of protocols for the general case of data transmission between computers, terminals, and their network elements.

6. Summary

- 6.1 This Contribution has attempted to lay the framework for an eventual comprehensive structure by Study Group I of the various parameters that need to be standardized in order to promote a unified VIDEOTEX service. The whole idea is to ensure that all Administrations are working toward solutions to the same questions, and also to facilitate comparisons between various proposals.

ANNEX

STANDARD TERMINOLOGY

1. The potential standardized parameters are divided into four categories; Display Characteristics, Character Repertoire, Line Control Procedures, and End-to-End Procedures, with brief definitions.
2. DISPLAY CHARACTERISTICS
 - 2.1 SCREEN STRUCTURE - logical arrangement of smallest possible picture elements within the defined display area.
 - 2.1.1 MATRIX ORIENTED - screen is divided horizontally and vertically into uniformly sized fields. This identifies two parameters frequently discussed:
 - A. NUMBER OF SYMBOLS PER ROW
 - B. NUMBER OF SYMBOL ROWS PER SCREEN

The general case of this is when the screen is divided into a multiple number of portions, each of which is divided horizontally and vertically into uniformly sized fields, which may vary portion to portion.
 - 2.1.2 FREE-FORM ORIENTED - independent addressability of each individual picture element, which allows for the highest possible display resolution.
 - 2.2 FIELD GEOMETRY - the arrangement of picture elements which defines the individual field within the chosen screen structure. Has meaning only when associated with a Matrix Oriented Screen Structure.
 - 2.2.1 BACKGROUND MATRIX - defined by a horizontal width (picture elements) and a vertical height (T.V. scan lines) that creates a rectangular field, where all such fields are contiguous within the display area.

2.2.2 FOREGROUND SYMBOLS

2.2.2.1 NON-GRAPHIC DOT MATRIX - this matrix is a rectangle that fits within a single Background Matrix field, and physically contains the picture elements that display all symbols (i.e., alphabetic characters, numeric characters, and other special symbols).

2.2.2.2 MOSAIC GRAPHIC MATRIX - relatively low-level resolution graphic representation, that subdivides the identically sized rectangle as the Background Matrix, into small rectangles. Usually referred to as graphics primitive.

2.3 DISPLAY ATTRIBUTES

2.3.1 COLOR INFORMATION - defines the precise physical attributes of each display page (i.e., visible images) as it relates to the physiological perception of color; the same intensity, saturation level, hue, used by the creator for all colors associated with each data base display page, must be automatically recreated on the receiving terminal screen.

2.3.1.1 MATRIX ORIENTED SCREEN STRUCTURE

- A. TOTAL NUMBER OF POSSIBLE COLORS - refers to the upper limit on the range of different colors that can be utilized.
- B. NUMBER OF POSSIBLE COLORS DISPLAYED SIMULTANEOUSLY - defines the effective limitation on the color palette available for any single display page.
- C. NUMBER OF POSSIBLE COLORS DISPLAYED IN A SINGLE FIELD - this limitation applies only with a Matrix Oriented Screen Structure, and the single fields have both a foreground and a background component.

2.3.1.2 FREE-FORM ORIENTED SCREEN STRUCTURE

- A. TOTAL NUMBER OF POSSIBLE COLORS - refers to the upper limit on the range of different colors that can be utilized.

COM I-No. 176-E

- B. NUMBER OF POSSIBLE COLORS DISPLAYED SIMULTANEOUSLY - defines the effective limitation on the color palette available for any single display page.

2.3.2 SPECIAL FEATURES - includes all unique aspects (not including color) of a display that the creator of a display page expects to be recreated at the receiving terminal.

2.3.2.1 MOTION - refers to the ability to simulate movement on the receiving terminal screen, by quickly updating the display page or a portion of the page, e.g., using downloaded software.

2.3.2.2 FLASHING - a highlighting mechanism that changes the visibility (intensity or color) of displayed symbols periodically.

2.3.2.3 CONCEAL - refers to a feature that causes some portion of a single page display to not be visible for a certain period of time, or until some specified event.

2.3.2.4 PROTECTED - ability to inhibit the receiving terminal from modifying any Display Attribute of any portion of a display page.

2.3.2.5 SCREEN BORDER - refers to that part of the visible display of a terminal that is outside the defined display area, with the degree of visibility dependent on the amount of overscan.

2.4 OTHER ISSUES

2.4.1 AUDIO - ability to combine audio and visual information as it is perceived at the receiving terminal.

2.4.2 PHERIPHERAL INTERFACES - this refers to an adjunct device with the ability to store and/or recreate information received by or generated from a terminal.

3. CHARACTER REPERTOIRE - this category defines all character sets and code extension techniques.

- 3.1 BASIC SYMBOL SET - the set of characters initially stored in memory, which are subject to modification and/or addition by the technique of downloading (ref. 4.3.3).
 - 3.1.1 ALPHANUMBERICS AND SPECIAL SYMBOLS - a set of foreground symbols which are contained within the non-graphic dot matrix.
 - 3.1.2 GRAPHICS - a set of foreground symbols which are contained within the mosaic graphic matrix.
- 3.2 TRANSMISSION CHARACTER SET - a set of codes which are utilized to control transmission of information and related attributes between remote stations (terminal - computer, terminal - terminal), which are transparent to the network.
 - 3.2.1 CONTROL COMMANDS - the subset which is utilized to direct the flow of text and initiate other procedures.
 - 3.2.2 COLOR CODES - the subset which provides color information for the associated symbol(s).
 - 3.2.3 SPECIAL CONTROLS - the subset which defines the attributes such as blinking, concealment, highlighting, etc., for the associated symbol(s).
- 3.3 DOWNLOADED SETS - character repertoire that is loaded into memory from a source such as a data base computer, that can supplement or replace the current character repertoire.
- 4. LINE CONTROL PROCEDURES - this category defines electrical, functional, and procedural characteristics used to establish and utilize the physical data path.
 - 4.1 CIRCUIT CHARACTERISTICS - describes the physical, electronic and logical properties of a data path.
 - A. SPEED - the rate of data flow over a given circuit, commonly defined as bits per second.
 - B. MODE - Half duplex; alternating transmission and reception. Full duplex; simultaneous transmission and reception.
 - C. FACILITIES - defines the physical path, such as the public telephone network (dial/leased line), using any of the following techniques: wire, coaxial cable, wave guide, satellite, fiber optics, etc.

- D. SYNCHRONIZATION - timing consideration; asynchronous, or synchronous with the logical data stream subdivision level being bit, character or message oriented.
 - E. PATH - Serial/Parallel
 - F. METHOD - Analog/Digital
 - G. TERMINAL/LINE/INTERFACE - defines the data, status, control and timing functions, (e.g., EIA RS 232C).
- 4.2 LINE PROTOCOL - the conventions that makes possible the desired actual or virtual circuit connection, data transfer, and circuit termination.
- 4.2.1 CALL ESTABLISH AND TERMINATE - the functional and procedural means to establish, maintain and release data links between remote stations.
 - 4.2.2 MESSAGE TRANSFER - the functional and procedural means to exchange data between remote stations.
 - A. ERROR DETECTION/CORRECTION - the means of ensuring that the data maintains integrity throughout the message transfer process.
5. END-TO-END PROCEDURES
- 5.1 AUTHORIZATION PROCEDURES AND SECURITY FUNCTIONS
- 5.1.1 AUTOMATIC TERMINAL ANSWERBACK - refers to the activity that is usually transparent to the terminal user, that occurs automatically in the terminal upon receipt of a special coded message (one or more characters) from the information source (i.e., computer). May provide information to the computer that allows it to restrict information, and to identify important capabilities of the terminal.
 - 5.1.2 USER IDENTIFICATION CODE - scheme by which an individual uniquely identifies themselves to the information source.
 - 5.1.3 PASSWORD - method by which an application within an information source computer may control access to certain data.

- 5.1.4 ENCRYPTION - refers to those type of schemes that encode the transmitted serial data bit stream into pseudo-random patterns, then decodes the received data stream back to its original form.

- 5.2 MESSAGE FLOW CONTROLS/ACCESS PROTOCOLS
 - 5.2.1 INFORMATION FRAMES - this section refers to rules governing the creation, utilization, and modification of display pages, and defines the entire dialog procedure between terminal user and data base computer.
 - 5.2.1.1 OPERATION COMMANDS - refers to specific instruction codes between the terminal user and the information source.
 - 5.2.2 ERROR MANAGEMENT MESSAGES AND PROCEDURES - allows for clear and concise understanding of all abnormal conditions, and defines appropriate actions allowed/required by terminal and information source. This includes automatic and manually initiated diagnostic routines.
 - 5.2.3 SYSTEM RESPONSES - provides universal rules for action/reaction during typical (non-error condition) dialog between information source (i.e., computer), terminal, and any other system element (e.g., network control center, international gateway, message/packet switching network).

- 5.3 COST ACCOUNTABILITY PROCEDURES - defines all schemes for obtaining usage-sensitive data (i.e., statistics gathering), and identifies the pricing/billing processes.

- 5.4 OTHER-SYSTEMS INTERFACE REQUIREMENTS - this section should contain a comprehensive specification of all rules that regulate the exchange of data between VIDEOTEX Services and any other service. This would include a detailed definition of those parameters which would differ from the ones required for intra-VIDEOTEX information provisioning.

APPENDIX C

International Telegraph and Telephone
Consultative Committee
(CCITT)

COM I-No. 178-E^{*})

Period 1977-1980

English only

Question: 19/I

Date: 20 June 1979

STUDY GROUP I - CONTRIBUTION No. 178
=====

SOURCE: AMERICAN TELEPHONE AND TELEGRAPH COMPANY

TITLE: SUMMARY OF VIDEOTEX STANDARDS ISSUES

1. Purpose

- 1.1 Study Group VIII has begun to consider a draft plan for an "S" series Recommendation which would describe the minimum characteristics for a Videotex terminal to be able to access an international Videotex service. This contribution summarizes the spectrum of issues that must be resolved in order to develop the international Videotex standard.
- 1.2 Study Group I should be aware of these various issues. A clear and complete definition of Videotex service by Study Group I should be developed with these issues in mind.

*)

Contribution retardée publiée seulement dans la langue recue (anglais), sans traductions supplémentaires, conformément, aux dispositions de la Résolution N°1, paragraphe III.4.d) adoptée par le VI^e Assemblée (1976).

Late Contribution published only in the language received (English), without further translations, in accordance with Resolution No. 1, paragraph III.4.d) VIth Plenary Assembly (1979).

Contribución retardada publicado sólo en el idioma en que se recibió (inglés), sin otras traducciones de conformidad con la Resolución N.º1, párrafo III.4.d), VI Asamblea Plenaria (1976).

2. Videotex service

2.1 The issues regarding Videotex terminal standards are summarized in Sections 3, 4, and 6, with conclusions in Section 7.

2.2 The Videotex service is understood as follows:

- a) a visual information service augmented with audio capability,
- b) types of calls which can be made are:
 - i) terminal-to-data base,
 - ii) terminal-to-terminal
 - iii) data base-to-terminal,
 - iv) data base provider-to-data base provider.

3. Display characteristics

- a) Television sets and terminals with built-in screens are the type of display media,
- b) three inputs to the television should be permitted:
 - i) a radio frequency composite video signal connected to the television's antenna leads,
 - ii) a baseband composite video signal connected to the television via an input jack,
 - iii) direct inputs to the television's red, green, and blue electron gun driver circuits.

The resulting picture with any of these three inputs must be satisfactory to the user.

- c) the number of symbols per row and number of rows permitted on the display screen is to be compatible with 525-scan line television sets used by many subscribers,
- d) a border is to be allowed on the display to compensate for vertical and horizontal overscan,
- e) any coloured alphanumeric characters cannot always be displayed on every coloured background with composite video (RF or baseband) inputs,

- f) characters formed with a 2 x 3 mosaic matrix may have practically any colour foreground and background combinations.

4. Character repertoire

4.1 Symbol sets

- a) Visual information for the Videotex display may be created by storing in the terminal:
 - i) alphanumeric character sets,
 - ii) mosaic graphics matrix sets,
 - iii) a memory space for symbols (alphanumeric or graphic) downloaded from the data base to the terminal,
 - iv) programs for creating an image utilizing graphics primitives from input data,
 - v) extra storage space for pel-by-pel addressing,
- b) a subset of the above can be defined as the "basic" character repertoire; the remaining may be defined as the "extended" character repertoire,
- c) the Videotex standard should allow all five types of symbol sets to be implemented.

4.2 Transmission character sets

4.2.1 Line level control characters

- a) If a binary synchronous type of protocol is implemented, the control characters in the C0 set of the ISO 2022 standard may be used,
- b) if a bit oriented type of protocol is implemented, these characters are not necessarily needed.

4.2.2 Peripheral device control

- a) Control characters and interfaces should be allocated for such peripheral terminal devices as printers and bulk storage devices.

4.2.3 Visualization parameter control

- a) Operation of the red, green, and blue electron gun driver circuits at intermediate on-levels is to be allowed. This permits more than eight colours.
- b) Simulated motion is provided by dynamically altering the colour of portions of images in a frame, making them disappear (appear) when their colour is set to (made different from) the background colour.

4.3 Transmission scheme

- a) A choice can be made between a 7 bit or 8 bit per character coding format of the ISO 2022,
- b) The "direct" and "composition" methods for transmitting accented characters should be considered and reconciled by selecting one or permitting a scheme that allows both to be used.

5. Line control procedures

5.1 Modem

- a) The appropriate choice of modem is:
 - i) the reversible half duplex modem with a backward channel (e.g., 1200/75 baud channels),
 - ii) a full duplex modem.

5.2 Transmission protocol

- a) Most protocols may be classified as:
 - i) echoplexing with manual transmission protocol,
 - ii) binary synchronous oriented protocol,
 - iii) bit oriented protocol,
- b) automatic transmission error detection and correlation is required,
- c) automated provision of master/slave transmission status facilitates the terminals users use of the service,

- d) serious consideration should be given to the work of Study Group VII on a layered protocol architecture,
- e) the public telecommunications network, a specialized network, or a packet switched network may be utilized for transmission. The Videotex protocol should permit transmission using any of these types of facilities or their combinations.

6. End-to-end procedures

6.1 Consideration should be given to authorization procedures and security functions such as:

- a) automatic terminal answerback/identification,
- b) user identification code,
- c) application password,
- d) data encryption.

6.2 Communications between different Videotex services will require compatible access protocols and message flow controls. This includes:

- a) information frames/pages,
- b) error management messages and procedures.

6.3 Cost accountability procedures must be considered.

6.4 Compatibility of Videotex services with Teletext, Teletex, Facsimile, etc. services should be considered. This consideration may require different standards than those which would be developed for Videotex-only services.

7. Conclusion

7.1 CCITT Recommendations should not be limited to what is currently economically feasible, but should be drafted with enough flexibility to permit future enhancements to the service as the capabilities of the technology evolve. This flexibility cannot be insured unless the impact of each of the issues detailed in this contribution are evaluated.

- 7.2 It is not desirable to rush into a final standard before reviewing and resolving these issues satisfactorily. A situation may result where it would be difficult (i.e., technically and economically) to provide new service features to meet user needs due to the lack of flexibility of equipment and software already installed.
- 7.3 It is suggested that time should be allowed to reflect the experience gained from Videotex trials and emerging Videotex services, into the Videotex standard. Many Administrations have announced their intentions to conduct such activities in 1980 and 1981, and this is the schedule that would seem to be the most appropriate.

APPENDIX D

Electronic Component Price Fluctuations 1976 to 1979 Council on Wage and Price Stability (COWPS)

(The pricing information was provided by COWPS at end of June, 1980 and is tabulated below)

TV Receivers

'76	-1.1%
'77	-6.1%
'78	-1.1%
'79	+1.2%

Analogue Amplifying Equipment

'76	-14.1%
'77	-14.0%
'78	-15.4%
'79	-11.0%

Other Analogue Devices

'76	-43.6%
'77	-27.6%
'78	-5.8%
'79	-0.7%

Digital Bipolar Integrated Circuits

'76	-16.4%
'77	-13.2%
'78	-28.4%
'79	-4.9%

Digital Analogue Interface

'76	-16.4%
'77	-30.1%
'78	-31.0%
'79	-6.5%

BIBLIOGRAPHIC DATA SHEET

1. PUBLICATION NO. NTIA Report 80-50		2. Gov't Accession No.	3. Recipient's Accession No.
4. TITLE AND SUBTITLE VIDEOTEX Systems and Services		5. Publication Date October 1980	
		6. Performing Organization Code	
7. AUTHOR(S) L.R. Bloom, A.G. Hanson, R.F. Linfield, D.R. Wortendyke		9. Project/Task/Work Unit No.	
8. PERFORMING ORGANIZATION NAME AND ADDRESS U.S. Department of Commerce National Telecommunications & Information Administration Institute for Telecommunication Sciences Boulder, CO 80303		10. Contract/Grant No.	
11. Sponsoring Organization Name and Address same		12. Type of Report and Period Covered	
		13.	
14. SUPPLEMENTARY NOTES			
15. ABSTRACT (A 200-word or less factual summary of most significant information. If document includes a significant bibliography or literature survey, mention it here.) <p>A new, consumer-oriented family of innovative information distribution services, generally termed VIDEOTEX, is being offered to the European and Japanese public. Several field trials are underway in the United States. Normally using a modified home TV receiver as the display terminal, services provide user access to broad varieties of computerized data banks. Distribution to the user is typically via broadcast TV (one-way services) or the switched telephone network (two-way, interactive services). Also, there exist hybrid services in which the requested service may be transmitted over a different medium from the received information. This report discusses representative services and distribution system architectures, potential impact on the telephone network, the need for and status of standards, and economic considerations for user and suppliers.</p>			
16. Key Words (Alphabetical order, separated by semicolons) Broadcast television; coding formats; communication; computer networks; data bank; data communication; data networks; display; Green Thumb; information distribution; information retrieval; information systems; network architecture; non-speech telecommunications; standards; systems architecture; telecommunications; telephone network; Teletext; television receiver; terminal; VIDEOTEX; Viewdata.			
17. AVAILABILITY STATEMENT <input checked="" type="checkbox"/> UNLIMITED <input type="checkbox"/> FOR OFFICIAL DISTRIBUTION.		18. Security Class. (This report) Unclassified	20. Number of pages 159
		19. Security Class. (This page) Unclassified	21. Price

