

Suitability of ANSI Standards for Quantifying Communication Satellite System Performance

Robert D. Cass



U.S. DEPARTMENT OF COMMERCE
C. William Verity, Secretary

Alfred C. Sikes, Assistant Secretary
for Communications and Information

August 1988

PREFACE

The NASA ACTS Experiment Program Manager, NASA Headquarters (EC), Washington, DC, has directed the Institute for Telecommunication Sciences (ITS) to provide technical support and guidance on end-to-end system performance experiments of the Advanced Communications Technology Satellite. This report covers Task 1 of this project and represents a joint effort with the internally funded ITS advanced satellite study program. This report is concerned with the application of American National Standards X3.102 and X3.141 to advanced satellites as a means of quantifying their end-to-end system performance.

Administrative and technical monitoring of this study was performed by Mr. Ronald Schertler of NASA-LeRC.

CONTENTS

	Page
LIST OF FIGURESvi
LIST OF TABLES.	vii
LIST OF ACRONYMS.	viii
ABSTRACT.	1
1. INTRODUCTION.	1
1.1 Evolution of the Communication Satellite and Its Role.	2
1.2 The Increasing Need for System Performance Measurements.	4
1.3 Purpose and Scope of Report.	5
2. OVERVIEW OF AMERICAN NATIONAL STANDARDS X3.102 AND X3.141	6
2.1 ANS X3.102 Approach.	7
2.2 ANS X3.141 Measurement Process	16
3. COMMUNICATION SATELLITE END-TO-END SYSTEM PERFORMANCE DEFINITIONS	22
3.1 Analog and Digital Link Parameters	22
3.2 TDMA, SS/TDMA, and DAMA System Performance Parameters.	27
3.3 Satellite-Augmented ISDN Systems	36
4. ACTS OVERVIEW, OPERATION, AND END-TO-END SYSTEM PERFORMANCE DEFINITIONS	36
4.1 ACTS Overview and Operation.	38
4.2 ACTS LBR System Performance Parameters	48
4.3 ACTS System Performance Experiment Design Considerations	58
5. CONCLUSION.	71
6. ACKNOWLEDGMENTS	72
7. REFERENCES.	73
APPENDIX: LINK BUDGET CALCULATIONS	75

LIST OF FIGURES

	Page
Figure 1. Interfaces between the end user and the data communication system (ANSI, 1983).	12
Figure 2. Typical subsystem interfaces (ANSI, 1983).	14
Figure 3. Truncation of the access time distribution (Seitz and Grubb, 1983).	17
Figure 4. User information bit transfer rate (Seitz and Grubb, 1983).	20
Figure 5. Overview of ANS X3.141 (ANSI, 1987).	21
Figure 6. ACTS scan and spot beam coverage.	39
Figure 7. Order wire/status/control routing diagram.	42
Figure 8. Up-link TDMA frame structure.	43
Figure 9. Down-link TDMA frame structure.	44
Figure 10. Typical ACTS LBR system communication session.	46
Figure 11. ACTS terrestrial interfaces.	60
Figure 12. Session profile (successful access).	64
Figure 13. Session profile (successful disengagement).	65
Figure 14. Unsuccessful access, blocked by MCS.	67
Figure 15. Unsuccessful access, blocked by the destination earth station.	68
Figure 16. Unsuccessful access, blocked by the destination user.	69
Figure 17. ACTS LBR communication system.	70
Figure A-1. Bit error rate vs. E_b/N_0	81

LIST OF TABLES

	Page
Table 1. Performance Outcome Summary (Seitz and Grubb, 1983)	8
Table 2. Matrix Representation of the Parameters	10
Table 3. ANS X3.141 System-Independent Reference Events (ANSI, 1987).	19
Table 4. Communication Satellite End-to-End System Performance Parameters.	25
Table 5. ACTS LBR System Performance Parameters.	49
Table 6. ACTS Performance Factors and Levels	59

LIST OF ACRONYMS

ACK	positive acknowledgement
ACTS	Advanced Communications Technology Satellite
AM	amplitude modulation
ANS	American National Standard
ANSI	American National Standards Institute
ARQ	automatic repeat request
B	bandwidth
BBP	baseband processor
BBPTP	BBP traffic route time plan
BPSK	binary phase shift keying
BTP	burst time plan
CB	control burst
C/No	carrier-to-noise density ratio
CO	central office
CPE	customer premises equipment
CRC	cyclic redundancy code
CTB	coded traffic burst
DAMA	demand assignment multiple access
dB	decibel
DBS	Direct Broadcast Service
DRP	data routing processor
DTB	down link traffic burst
E&M	ear and mouth
E_b/N_o	bit energy-to-noise density ratio
EIRP	equivalent isotropically radiated power
FDM	frequency division multiplexing
FDMA	frequency-division multiple-access
FEC	forward error control
FM	frequency modulation
G	receive antenna gain
G/T_s	receive station figure of merit
G_t	transmit antenna main-beam gain
HBR	high burst rate

IF intermediate frequency
 ISDN Integrated Services Digital Network
 ITS Institute for Telecommunication Sciences
 LBR low burst rate
 LNA low noise amplifier
 MCP multibeam communication package
 MCS master control station
 N total noise power
 NAK negative acknowledgement
 NASA National Aeronautics and Space Administration
 NGS NASA ground station
 OWB order wire burst
 Pe probability of bit error
 PM phase modulation
 Pt transmitter output power
 QPSK quadrature phase shift keying
 RAB receive acquisition burst
 Rb bit rate
 RB reference burst
 rf radio frequency
 SSPA solid-state power amplifier
 SS/TDMA satellite-switched time-division multiple-access
 TAB transmit acquisition burst
 Tb transmitted bit duration
 Te equivalent noise temperature
 TEW tracking error word
 TDM time-division multiplex
 TDMA time-division multiple-access
 T_s system noise temperature
 TWTA traveling wave tube amplifier
 UTB uncoded traffic burst
 UW unique word
 VSAT very-small-aperture terminal



**SUITABILITY OF ANSI STANDARDS FOR
QUANTIFYING COMMUNICATION SATELLITE SYSTEM PERFORMANCE**

Robert D. Cass*

This report details a study on the application of American National Standards X3.102 and X3.141 to various classes of communication satellite systems from the simple analog "bent-pipe" to NASA's Advanced Communications Technology Satellite (ACTS). These standards are proposed as a means for quantifying the end-to-end communication system performance of communication satellite systems. An introductory overview of the two standards are given followed by a review of the characteristics, applications, and advantages of using X3.102 and X3.141 to quantify the performance these classes of communication satellites. The report concludes with a description of the application of these standards to ACTS.

Key words: ACTS; American National Standard; baseband switching; DAMA; digital communication; ISDN; system performance measurement; SS/TDMA; TDMA; users

1. INTRODUCTION

It has been argued that communication satellites are losing their monopoly in the long-haul transmission market (Byrne, 1985). With the day-by-day increase in optical fiber cable miles and long-haul communication providers such as Sprint touting the advantages of optical fiber communications, the communication satellite industry future does indeed seem dim. However, one must remember that the imminent demise of terrestrial microwave systems was incorrectly predicted with the advent of communication satellites.

Today, both communication satellites and terrestrial microwave systems coexist in a highly competitive market. Although, the immediate competitive threat imposed by fiber is to the terrestrial microwave systems, this does not imply that the communication satellite industry and service-providers need do nothing to enhance their product. To remain a viable and profitable industry, communication satellites will need to evolve beyond the role of simple, long-haul transmission links. They will need to become an integral part of data communication networks such as an Integrated Services Digital Network (ISDN).

*The author is with the Institute for Telecommunication Sciences, National Telecommunications and Information Administration, U.S. Department of Commerce, Boulder, CO 80303-3328.

Commensurate with this evolution, the ways by which communication satellite system performance is measured and specified needs to be reevaluated.

1.1 Evolution of the Communication Satellite and Its Role

Lovell and Cuccia (1984) of NASA have classified communication satellites into three categories:

1. Type A satellites carrying one or more simple transponders and earth-coverage antenna.
2. Type B satellites carrying multiple fixed antennas and multiple transponders, where under ground control the interconnectivity between the beams and transponders can be rearranged.
3. Type C satellites, similar to type B but with on board message-switching capabilities.

The transponders for both type A and type B satellites are analog and support single or multiple communication channels. Type C satellites dynamically control the beam coverage areas and route the message traffic to the appropriate beams. In some designs, (NASA's Advanced Communications Technology Satellite [ACTS] for example) the transponders are digital and regenerate the signal.

The first commercially viable communication satellites were simple analog microwave repeaters in geostationary orbit. Their main function was to provide point-to-point, high volume trunking for telephone and television systems. Even with today's increased transponder capacity and down-link power, higher operating frequencies, time-division multiple-access (TDMA), digital modulation, and frequency reuse, communication satellites are still not much more than repeaters.

Unfortunately, these high volume, point-to-point satellite trunking services are those most threatened by optical fiber systems. Traditionally, for geographic separations greater than 800 km, point-to-point satellite trunking has been the most economical transmission method (Byrne, 1985). However, with the introduction of optical fiber transmission links this distance advantage is decreasing. Thus, future communication satellite systems will have to look elsewhere for their market share.

Fortunately, the demand for point-to-multipoint service is increasing. This demand has been fueled by higher frequency and higher power satellites

such as those planned for Direct Broadcast Service (DBS) and advances in earth station technology reducing the costs of small receive-only earth stations. For \$1000 to \$2000, almost any broadcast service can be received in the remotest parts of the country. Multipoint-to-point, e.g., oil pipeline monitoring systems (Gonze, 1987), is another service that communication satellites are beginning to provide. Both of these are services that optical fiber transmission systems would be hard pressed to provide economically. Additionally, satellite systems for mobile communication applications are being developed, a service that fiber cannot provide. All of these services, however, are still using the satellite basically as a simple repeater.

The NASA ACTS program takes the satellite beyond this simple repeater role by providing an experimental advanced communication satellite that will demonstrate improved repeater technology and on board baseband switching for traffic routing and network control. The satellite will operate in the Ka band (17 to 31 GHz) with small diameter spot beams and cross polarization to reduce interchannel interference and to increase frequency reuse. The on board switch will operate in either a microwave mode, switching at the intermediate frequency (IF) like type C satellites (INTELSAT VI), or in a baseband mode, operating as a demand-assignment multiple-access (DAMA) system with digital signal regeneration and forward error control coding. Thus, the role of the communication satellite is evolving from one of a simple point-to-point transmission link to that of a network switching center, further enhancing the communication satellite's ability to provide point-to-multipoint and multipoint-to-point network connectivity.

Satellites, such as ACTS, and inexpensive very-small-aperture terminals (VSAT) will enable communication satellites to provide economical, thin-route, two-way communication services to sparsely populated and inaccessible areas. These satellite systems will also facilitate two-way mobile communication. Additionally, these satellites will fit very naturally into data networks such as an ISDN, where the satellite itself becomes one of the ISDN switching nodes.

Satellites with on board ISDN switching capability could be used to provide private ISDN services for large corporations. They could interconnect geographically dispersed locations with high-volume 23B+D Primary Rate ISDN (1.544 Mb/s) or multiple-megabit per second broadband ISDN circuits. These satellites could also support two-way, thin-route traffic with direct links of

satellites could also support two-way, thin-route traffic with direct links of the Basic ISDN interface (2B+D channels at 144 kb/s) to the customer premises equipment (CPE). Other satellite-based or satellite-augmented ISDN applications include small transportable terminals for temporary network access and mobile ISDN connectivity. These ISDN-compatible satellites working in parallel with fiber trunks and terrestrial switches could also provide network backup and quick emergency service restoration.

1.2 The Increasing Need for System Performance Measurements

With communication satellite systems evolving into new roles, evolution is also required in performance specification and measurement methods for these systems. Two strong reasons are pushing this need:

1. Communication satellite systems are being used for a larger portion of data communication networks.
2. Users are becoming less concerned with the technical design issues of data communication systems and more concerned with finding systems that meet their needs.

When satellites provide simple analog repeater service, the users are primarily concerned with the system capacity, measured as the number of analog voice circuits or video channels the system can support. This is a function of the modulation techniques and the carrier-to-noise density ratio (C/N_0) of the total satellite link (where C/N_0 is established by the basic link budget calculations). Very often the users are not experienced or interested in the details of satellite link budget calculations; however, they are very interested in how well the system meets their capacity and availability requirements. Thus, users generally buy service from satellite service providers who design the users' links. Once established, the links are dedicated full time to the users.

The situation for digital satellite transmission links is not much different from that for analog. Capacity is still the yardstick for measuring performance and it still depends on link budget calculations. (The signaling rate-dependent, bit energy-to-noise density ratio [E_b/N_0] is used in place of C/N_0 as the primary link budget parameter.) However, capacity is now measured as the user-information bit rate with a specified bit error probability (P_e). The E_b/N_0 link parameter fixes P_e for given source and error-control coding and

probabilities and information transfer rate in addition to system availability. Again the users typically go to satellite service providers to obtain the links they need. Also, as in the analog case, once the links are established, they are dedicated full time to the users.

With communication satellites incorporating more of the network switching functions and thus more users accessing the network on a demand assignment multiple access (DAMA) basis, link budget calculations no longer fully specify system performance. Users are becoming concerned with parameters such as access and disengagement time and blocking probability. The transmission link is also more dynamic in these type C satellites, with forward error-control coding and reduced transmission rates "switched in" during rain fades.

Quantifying the performance of these advanced type C satellites can become an arduous task. However, if one views these satellite systems as the digital communication networks they are becoming, the task is quite manageable. This is because of two standards approved by the American National Standards Institute (ANSI), American National Standards (ANS) X3.102 and ANS X3.141, for specifying and measuring data communication system performance with user-oriented performance parameters. These standards define parameters and measurement methods for quantifying data communication system performance from the user's point of view, independent of system design and implementation. ANS X3.102 and ANS X3.141 provide the data communication system user a "common yardstick" for comparing how well dissimilar systems--satellite, optical fiber, microwave, or any other transmission media and switching systems--meet their needs. ANS X3.102 and ANS X3.141 can be used to help identify what each system does best. And the user does not need to know how the system is designed or implemented.

From the service provider's point of view, ANS X3.102 and ANS X3.141 offer a convenient means for comparing their service against a competitor's. These standards can also be used to track system degradations and help identify potential bottlenecks. They are used to augment the link budget and capacity calculations for fully describing the system performance.

1.3 Purpose and Scope of Report

This report focuses on communication satellite system performance measurements and specifications. The purpose is to show the suitability of

ANS X3.102 and ANS X3.141 for quantifying the end-to-end system performance of current and future advanced communication satellite systems such as ACTS.

This report is divided into several major sections. Section 2 presents an overview of ANS X3.102 and ANS X3.141 and how they are used to quantify communication system performance. Section 3 presents a discussion on how ANS X3.102 and ANS X3.141 can be used to quantify the performance of the various type A, B, and C and TDMA satellite systems. Section 4 presents a brief overview of NASA's ACTS and how it operates from the user's perspective. It then concentrates on how to apply ANS X3.102 and ANS X3.141 system performance measurement concepts to the ACTS system. It concludes with a short discussion on the design of an ACTS system performance experiment using the framework of ANS X3.141. The appendix gives an overview of link budget calculations.

2. OVERVIEW OF AMERICAN NATIONAL STANDARDS X3.102 AND X3.141

In the past, the data communication community has had difficulty in getting the best (and least expensive) data communication systems that fit its needs. To help solve this problem, ANSI approved the two data communication systems performance standards:

1. The American National Standard for Information Systems--Data Communication Systems and Services--User-oriented Performance Parameters, ANS X3.102 (ANSI 1983).
2. The American National Standard for Information Systems--Data Communication Systems and Services--Measurement Methods for User-oriented Performance Evaluation, ANS X3.141 (ANSI 1987).

These two standards form the basis of the "functional approach" to data communication system procurement described in Seitz and Grubb (1983).

The benefits of using this functional approach and of these ANSI standards are many. To the data communication system users, their requirements are precisely defined; they do not need to become system designers and they can specify the system that best fits their needs and budgets without being constrained to a particular design. To the data communication system designers and service providers, their ability to assess existing and proposed new services from the user's perspective is improved, allowing them to identify areas for improvement and/or cost reduction without sacrificing system

performance. And to the data communication experimenters and researchers, they now have the methods and tools for conducting and analyzing repeatable data communication system performance measurements on experimental systems such as ACTS.

2.1 ANS X3.102 Approach

End-to-end system performance is described by the performance of three system functions: access, user information transfer, and disengagement. These system functions are quantified by three performance outcomes: successful performance (speed), incorrect performance (accuracy), and nonperformance (reliability). Seitz and Grubb (1983) define these performance outcomes as follows:

1. Successful Performance. The function is completed within a specified maximum performance time, and the result or output is exactly what was intended. A familiar example is successful connection to the correct called party in a voice telephone call.
2. Incorrect Performance. The function is completed within the specified maximum performance time, but the result or output is somehow different from what was intended. A familiar example is the connection to a "wrong number" (as a result of a system switching error) in a voice telephone call.
3. Nonperformance. The function is not completed within a specified maximum performance time. A familiar example is the blocking of a voice telephone call attempt by the system (as indicated by a "all trunks busy" signal).

A summary of the performance outcomes that apply to the various system functions is shown in Table 1. Incorrect performance is subdivided into three outcomes: content error, where the information is in error; location error, where the information was sent to the wrong location; and extra event, where unrequested information was received. Nonperformance is subdivided into two outcomes: system nonperformance, where the system is responsible for the outage; and user nonperformance, where the user is responsible for the outage. Nonperformance outcomes due to user nonperformance are excluded from the sample space and system performance calculation as these do not measure any functions performed by the system. The bit transfer and block transfer functions shown in Table 1 are subsets of the user information transfer function.

The major effort in applying ANS X3.102 to end-to-end data communication system performance measurements is selecting the appropriate performance

Table 1. Performance Outcome Summary (Seitz and Grubb, 1983)

PRIMARY FUNCTIONS	OUTCOMES INCLUDED IN SAMPLE SPACE						
	SUCCESSFUL PERFORMANCE	CONTENT ERROR	LOCATION ERROR	SYSTEM NON-PERFORMANCE		USER NON-PERFORMANCE	EXTRA EVENT
ACCESS	✓		✓	(DENIAL)	(OUTAGE)	✓	
BIT TRANSFER	✓	✓	✓	✓		✓	✓
BLOCK TRANSFER	✓	✓	✓	✓		✓	✓
DISENGAGEMENT	✓			✓		✓	

parameters. Sections 3 and 4 of this report address this for several classes of communication satellites. Table 2 lists, in matrix form, the 21 ANS X3.102 performance parameters defined in ANSI (1983). Listed are 17 primary performance parameters that quantify the performance criteria (speed, accuracy, and reliability) for the three communication system functions (access, user information transfer, and disengagement). The table also shows four ancillary parameters that relate the user's impact on the speed of the three system functions.

The ANS X3.102 performance parameters are defined in such a way that they can be applied to any data communication system or service for all topologies, protocols, codes, or other design characteristics (ANSI, 1987). They apply to both connection-oriented systems like the public-switched telephone network, and connectionless packet-switched networks like ARPANET. Also, unlike most standards, ANS X3.102 gives only the parameter definitions, not specific parameter values. The values of the parameters are determined by the context of the user's specific requirements. Additionally, only a subset of the performance parameters need be specified if it fully describes the user's performance requirements.

2.1.1 Access

Four primary performance parameters and one ancillary performance parameter are defined for the access function. These parameters are Access Time, Incorrect Access Probability, Access Denial Probability, Access Outage Probability, and User Fraction of Access Time (see Table 2). ANSI (1983) and Seitz and Grubb (1983) give justifications for the selection of these parameters and their mathematical definitions. The access function is defined as follows:

The access function begins upon issuance of an "access request" signal or its implied equivalent at the interface between a user and the data communication system. It ends when the first bit of source user information is input to the system (after connection establishment in connection-oriented services). It includes all activities traditionally associated with physical circuit establishment (e.g., dialing, switching, and ringing) as well as any activities performed at higher protocol levels (e.g., X.25 virtual circuit establishment).

Table 2. Matrix Representation of the Parameters (ANSI, 1983).

FUNCTION	PERFORMANCE CRITERION			PERFORMANCE TIME ALLOCATION
	SPEED	ACCURACY	RELIABILITY	
ACCESS	ACCESS TIME	INCORRECT ACCESS PROBABILITY	ACCESS DENIAL PROBABILITY ACCESS OUTAGE PROBABILITY	USER FRACTION OF ACCESS TIME
USER INFORMATION TRANSFER	BLOCK TRANSFER TIME	BIT ERROR PROBABILITY BIT MISDELIVERY PROBABILITY EXTRA BIT PROBABILITY BLOCK ERROR PROBABILITY BLOCK MISDELIVERY PROBABILITY EXTRA BLOCK PROBABILITY	BIT LOSS PROBABILITY BLOCK LOSS PROBABILITY	USER FRACTION OF BLOCK TRANSFER TIME
		USER INFORMATION BIT TRANSFER RATE	TRANSFER DENIAL PROBABILITY	USER FRACTION OF INPUT/OUTPUT TIME
DISENGAGEMENT	DISENGAGEMENT TIME	DISENGAGEMENT DENIAL PROBABILITY		USER FRACTION OF DISENGAGEMENT TIME

Legend:



Primary Parameters



Ancillary Parameters

The speed performance criterion is described by Access Time, the elapsed time between the originating user issuing an access request (e.g., pick up the phone) and the first bit of user information entering the system.

The accuracy performance criterion is described by the Incorrect Access Probability, the probability of the system making a wrong connection. This parameter generally applies to connection-oriented systems only, where the misconnection is typically due to switching or address errors. The user dialing a wrong number is not included in this parameter because that is not a system-caused error.

The reliability performance criterion is described by the performance parameters Access Denial Probability and Access Outage Probability. Access Denial Probability is the probability that the system will block the user's call, e.g., "all circuits are busy." Access denial also occurs when the time to access the system exceeds the Access Time threshold depicted in Figure 1. As defined in ANSI (1983), the Access Time threshold is three times the mean Access Time. If an access attempt exceeds this threshold it is counted as an Access Denial. The Access Outage Probability is the probability that the system does not respond to the request for service, e.g., the user does not get a "dial tone" when he/she picks up the phone to place a call. This outage is due to part or all of the system being "down."

The ancillary performance parameter associated with access is the User Fraction of Access Time. This is the length of time the users are responsible for processing the access request, e.g., the length of time it takes to "dial" the number and answer the phone.

2.1.2 User Information Transfer

Eleven primary performance parameters and one ancillary performance parameter are defined for the user information transfer function. These parameters are Block Transfer Time, User Information Bit Transfer Rate, Bit Error Probability, Block Error Probability, Bit Misdelivery probability, Block Misdelivery Probability, Extra Bit Probability, Extra Block Probability, Bit Loss Probability, Block Loss Probability, Transfer Denial Probability, User Fraction of Block Transfer Time, and User Fraction of Input/Output Time (see Table 2). ANSI (1983) and Seitz and Grubb (1983) give justifications for the

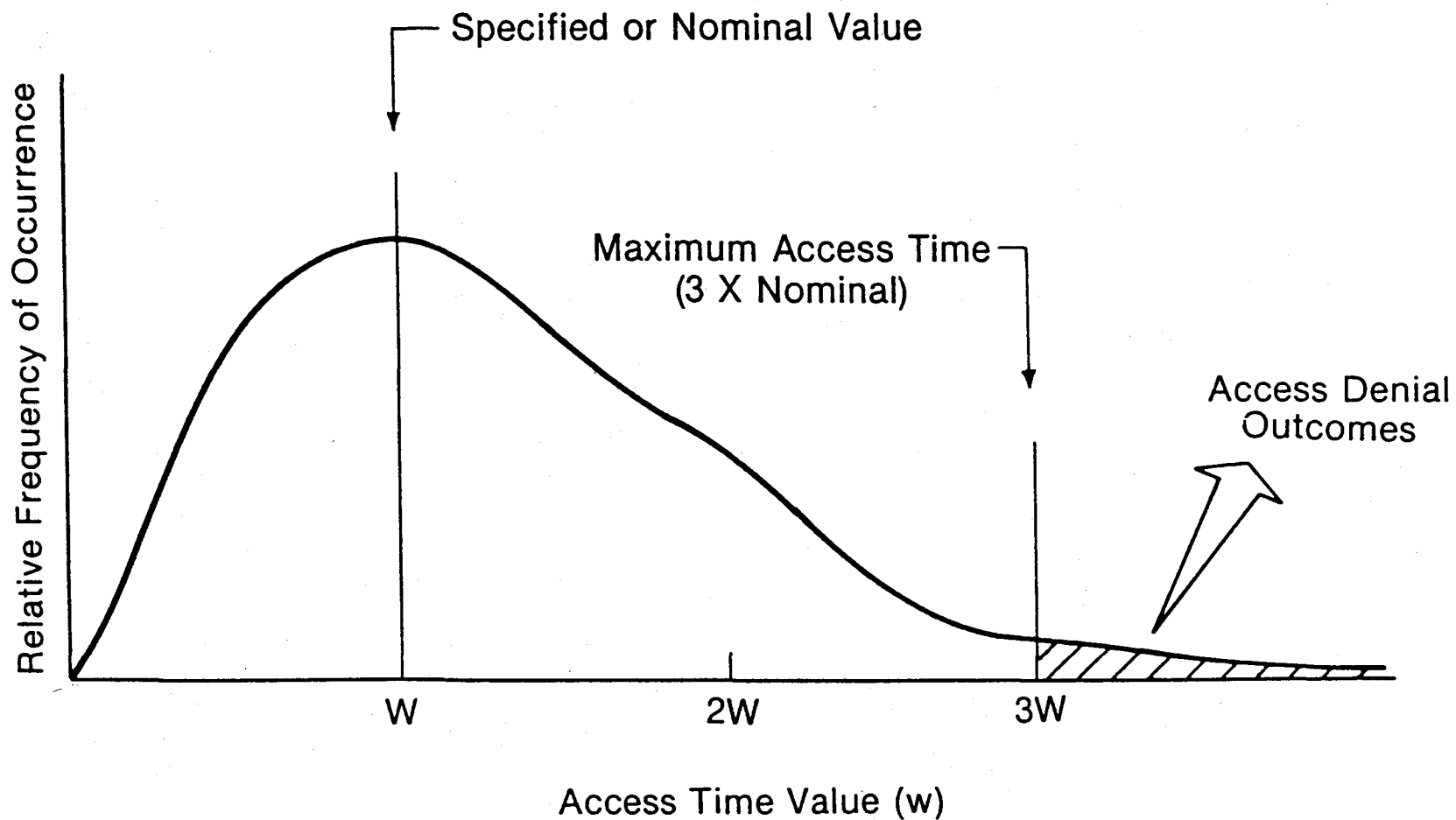

Figure 1. Truncation of the access time distribution (Seitz and Grubb, 1983).

selection of these parameters and their mathematical definitions. The user information transfer function is defined as follows:

The user information transfer function begins when the access function ends. The user information transfer function ends when the last "disengagement request" in a particular data communication session is issued. It includes all formatting, transmission, storage, error control, and media conversion activities performed between start of transfer and completion of delivery, including any needed retransmissions within the system.

The speed performance criterion is described by the Block Transfer Time and User Information Bit Transfer Rate. The Block Transfer Time is the average elapsed time between the start of a block transfer attempt and a Successful Block Transfer, i.e., the length of time a user information block is in transit between the source and destination users. As with all the block parameters, a block of user information may be any contiguous stream of bits that has meaning to the users, e.g., a single ASCII character (7 bits) or a 128-byte X.25 packet. The User Information Bit Transfer Rate is the total number of Successful Bit Transfer outcomes in an individual transfer sample divided by the input/output time for that sample (ANSI, 1983). As shown in Figure 2, the input and output times may be different in some systems (usually packet-switched systems). The longest time is taken as the divisor, thus giving the slower of the two possible rates.

The accuracy performance criterion is described by six of the bit/block performance parameters. The Bit and Block Error Probabilities express the likelihood that a unit of user information transferred from a source user to the intended destination user is delivered with incorrect binary content. The Bit and Block Misdelivery Probabilities specify the portion of bits and blocks that was transferred from a source user to an unintended destination user. The Extra Bit and Extra Block Probabilities express the likelihood that the information delivered to a destination user will contain duplicate bits or blocks or other extra information not output by the source user.

The reliability performance criterion is expressed by two of the bit/block performance parameters. The Bit Loss and Block Loss Probabilities express the likelihood that the system will fail to deliver a unit of user information to the intended destination user within the specified maximum transfer time. The

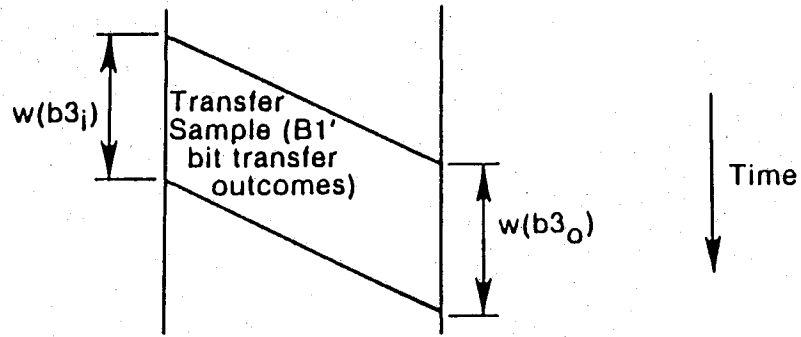

Case 1. No rate conversion : $w(b3_i) = w(b3_o)$

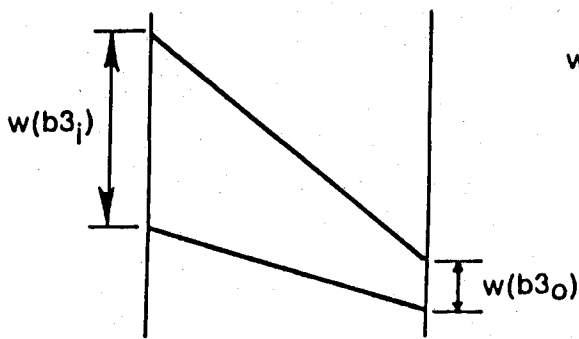

Case 2. Rate increase:
 $w(b3_i) > w(b3_o)$

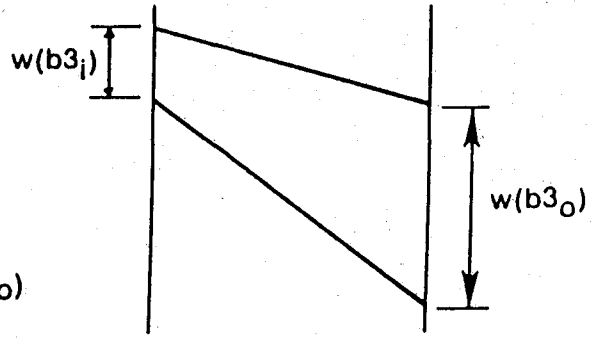

Case 3. Rate reduction :
 $w(b3_i) < w(b3_o)$

$$\text{User Information Bit Transfer Rate } R(b)_s = \frac{B1_s}{\text{Max} [w(b3_i) \text{ or } w(b3_o)]}$$

$B1_s$ = Total Successful Bit Transfer outcomes in the transfer sample.

Figure 2. User information bit transfer rate (Seitz and Grubb, 1983).

threshold for this maximum transfer time is defined as three times its nominal value, similar to the threshold for access denial shown in Figure 1.

The Transfer Denial Probability expresses the likelihood of an unacceptable degradation in the performance of a data communication service during user information transfer. Transfer denial is defined to occur whenever the performance observed during a transfer sample is worse than the threshold of acceptability for any of the four supported user information transfer parameters: Bit Error Probability, Bit Loss Probability, Extra Bit Probability, and user information transfer Rate. ANSI (1983) defines the threshold for the probability parameters as the fourth root of the specified probability value, e.g., a specified Bit Error Probability of 10^{-6} has a transfer denial threshold error probability of 3.16×10^{-2} . The threshold for User Information Transfer Rate is defined as three times its nominal value, similar to the threshold for Access Denial shown in Figure 1.

The ancillary performance parameters associated with user information transfer are the User Fraction of Block Transfer Time and the User Fraction of Input/Output Time. The User Fraction of Block Transfer Time is the length of time the user has control of the block transfer, e.g., stopping the information transfer to read a screen full of text. The User Fraction of Input/Output Time is the time the user has control of the input or output of the system, e.g., typing slower than the system can accept characters. As with the ancillary parameter for access, these give a measure for the impact of the user on the end-to-end system performance.

2.1.3 Disengagement

Two primary performance parameters and one ancillary performance parameter are defined for the disengagement function. These parameters are Disengagement Time, Disengagement Denial Probability, and User Fraction of Disengagement Time (see Table 2). ANSI (1983) and Seitz and Grubb (1983) give justifications for the selection of these parameters and their mathematical definitions. The disengagement function is as follows:

There is a disengagement function associated with each participant in a data communication session. Each disengagement function begins on issuance of a "disengagement request." The disengagement function ends, for each user, when (1) disengagement has been requested for that user; and (2) that user is able to initiate a new access attempt.

Disengagement includes both physical circuit disconnection (where required) and higher-level protocol termination activities such as X.25 virtual circuit clearing.

The speed performance criterion is described by Disengagement Time parameter, the average time a user must wait after requesting disengagement from a data communication session for the system to successfully accomplish the disengagement function (Seitz and Grubb, 1983). The accuracy and reliability performance criterion is described by the Disengagement Denial Probability parameter, the likelihood that the system will fail to disconnect a user from the communication session within a specified maximum time after a disengagement request has been issued.

The ancillary performance parameter associated with disengagement is the User Fraction of Disengagement Time. This is the time required for the user to initiate the disconnect request, e.g., the time required for the user not originating the disconnect request to respond to the system-generated disconnect request in a "four-way handshake" system.

Access Outage Probability along with the Transfer Denial Probability are used to quantify the commonly used system parameter--system availability.

2.2 ANS X3.141 Measurement Process

The end-to-end performance of a data communication system can be measured and quantified in terms of the ANS X3.102 performance parameters with the ANS X3.141 Measurement Process shown in Figure 3. The inputs to the process are the measurement objectives and the digital signals observed at the user/system interfaces. The outputs from the process are the estimated mean values and associated precision and variability statistics (e.g., confidence limits, histograms, and regression coefficients) of the performance parameters selected to characterize the system (ANSI, 1987).

Three measurement objectives are defined in ANS X3.141 (ANSI 1987):

1. Absolute Performance Characterization. Establishing the performance baseline of the system.
2. Simple Hypothesis Test. Measuring to see if the system performance is within some previously stated bounds.
3. Analysis of Factor Effects. Measuring to see how different system configurations affect system performance.

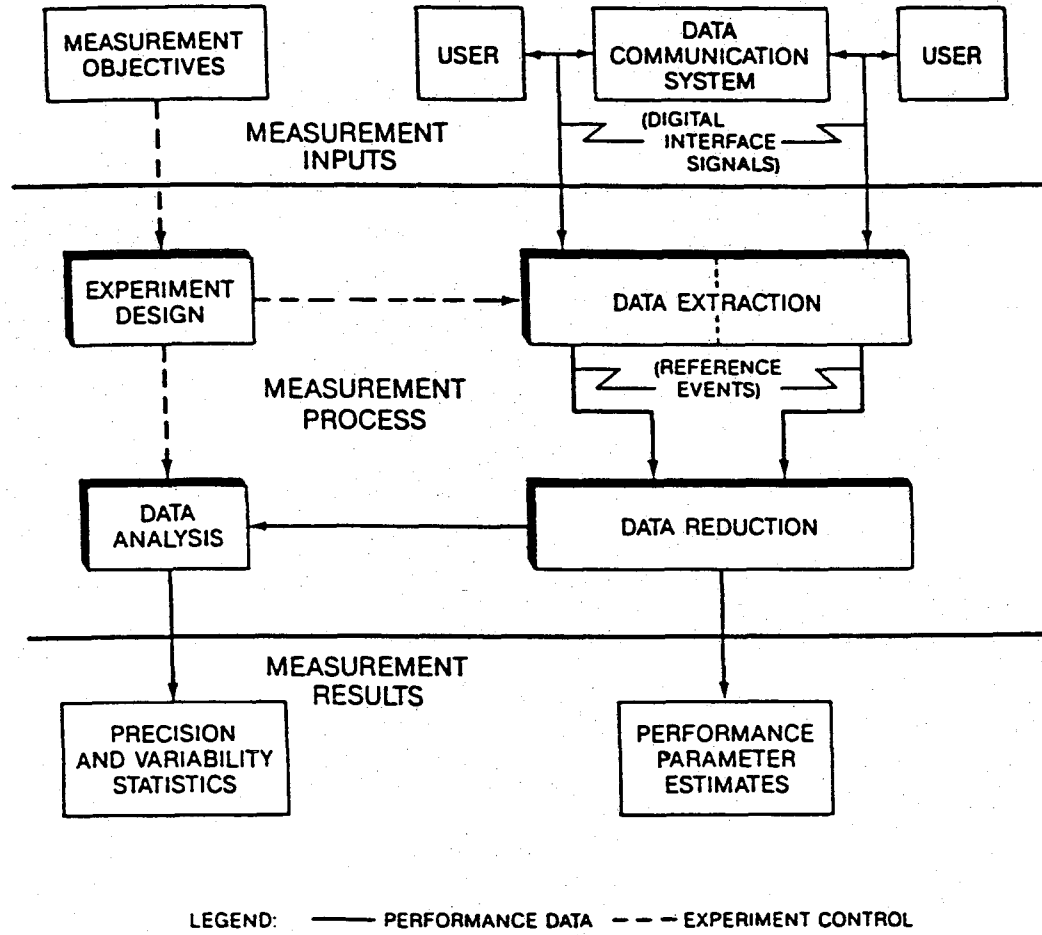

Figure 3. Overview of ANS X3.141 (ANSI, 1987).

System designers, service providers, and experimenters are interested in the first and third objectives for determining the basic system performance characteristics. Users are interested in the second objective for determining if the system meets their performance requirements.

As shown in Figure 3, the measurement process is carried out in four steps:

1. Experiment Design. A detailed experiment plan is developed from the desired measurement objectives. The specific performance information to be collected is identified and individual test conditions set.
2. Data Extraction. Selected pairs of digital user/system interfaces are monitored in real time. A chronological event history of the nature and time relevant interface events occur is recorded. (Table 3 lists the generic ANS X3.141 reference events that correlate to these system-specific reference events.)
3. Data Reduction. Estimated values of the selected performance parameters are generated from the event histories recorded during the data extraction step.
4. Data Analysis. The precision and variability of the individual parameter estimates is determined.

(ANSI [1987] presents an in-depth description of these steps and gives a detailed example of the ANS X3.141 measurement process.)

The first step in using ANS X3.141 for measuring data communication system performance is to describe a user-oriented view of the data communication system. This is done by defining who or what the users are and the specific user/system interfaces. ANSI (1983) defines four data communication system user/system interfaces as shown in Figure 4. The users can range from human operators to application programs running in host computers. It is also possible for the users to be other data communication systems; here the user/system interfaces are the subsystem interfaces shown in Figure 5.

During a communication session, information is transferred across the monitored user/system or subsystem interfaces. This information transfer constitutes an interaction with the system, referred to by ANS X3.102 as "interface events." Certain key interface events are identified as events to be counted, timed, or compared for calculating the performance parameter values (Seitz and Grubb, 1983).

With the user/system interface and key interface events identified, the measurement process is carried out. As part of the data reduction process, key

Table 3. ANS X3.141 System-Independent Reference Events (ANSI, 1987)

FUNCTION	REFERENCE EVENT	SYSTEM IMPACT	PERFORMANCE SIGNIFICANCE
ACCESS	1. ACCESS REQUEST	REQUESTS INITIATION OF DATA COMMUNICATION SESSION AND COMMITS THE ORIGINATING USER TO PARTICIPATE.	BEGINS ACCESS FUNCTION STARTS THE COUNTING OF ACCESS TIME.
	2. NONORIGINATING USER COMMITMENT	IN A CONNECTION-ORIENTED DATA COMMUNICATION SESSION, INDICATES NONORIGINATING (CALLED) USER WILLINGNESS TO PARTICIPATE.	ELIMINATES INCORRECT ACCESS AS A POSSIBLE ACCESS OUTCOME.
	3. SYSTEM BLOCKING SIGNAL	NOTIFIES ORIGINATING USER THAT THE SYSTEM CANNOT SUPPORT A REQUESTED DATA COMMUNICATION SESSION.	IDENTIFIES ACCESS ATTEMPT OUTCOME AS ACCESS DENIAL.
	4. USER BLOCKING SIGNAL	NOTIFIES SYSTEM THAT THE ISSUING USER WILL NOT SUPPORT A REQUESTED DATA COMMUNICATION SESSION.	IDENTIFIES ACCESS ATTEMPT OUTCOME AS USER BLOCKING (EXCLUDED FROM SYSTEM PERFORMANCE MEASUREMENT.)
	5. START OF BLOCK INPUT TO SYSTEM	TRANSFERS ONE OR MORE BITS AT BEGINNING OF USER INFORMATION BLOCK FROM SOURCE USER TO SYSTEM.	WHEN BLOCK IS THE FIRST BLOCK IN A DATA COMMUNICATION SESSION (AFTER NONORIGINATING USER COMMITMENT IN CONNECTION-ORIENTED SESSIONS), COMPLETES ACCESS FUNCTION AND BEGINS USER INFORMATION TRANSFER. STOPS THE COUNTING OF ACCESS TIME.
USER INFORMATION TRANSFER	6. START OF BLOCK TRANSFER	AUTHORIZES THE SYSTEM TO TRANSMIT A GIVEN USER INFORMATION BLOCK.	(1) BEGINS BLOCK TRANSFER FUNCTION AND STARTS THE COUNTING OF BLOCK TRANSFER TIME. (2) WHEN BLOCK PRECEDES THE FIRST BLOCK IN A TRANSFER SAMPLE, BEGINS COLLECTION OF THE SAMPLE AND STARTS THE COUNTING OF SAMPLE INPUT TIME. (3) WHEN BLOCK IS THE LAST BLOCK IN A TRANSFER SAMPLE, COMPLETES INPUT OF SAMPLE AND STOPS THE COUNTING OF SAMPLE INPUT TIME
	7. END OF BLOCK TRANSFER	TRANSFERS A GIVEN USER INFORMATION BLOCK TO THE DESTINATION USER, WITH APPROPRIATE NOTIFICATION TO THAT USER WHERE REQUIRED.	(1) COMPLETES BLOCK TRANSFER FUNCTION AND STOPS THE COUNTING OF BLOCK TRANSFER TIME. (2) WHEN BLOCK PRECEDES THE FIRST BLOCK IN A TRANSFER SAMPLE, BEGINS OUTPUT OF THE SAMPLE AND STARTS THE COUNTING OF SAMPLE OUTPUT TIME (3) WHEN BLOCK IS THE LAST BLOCK IN A TRANSFER SAMPLE, COMPLETES COLLECTION OF THE SAMPLE AND STOPS THE COUNTING OF SAMPLE OUTPUT TIME.
DISENGAGEMENT	8. DISENGAGEMENT REQUEST	REQUESTS TERMINATION OF A USER'S PARTICIPATION IN A DATA COMMUNICATION SESSION.	BEGINS DISENGAGEMENT FUNCTION STARTS THE COUNTING OF DISENGAGEMENT TIME.
	9. DISENGAGEMENT CONFIRMATION	CONFIRMS TERMINATION OF A USER'S PARTICIPATION IN A DATA COMMUNICATION SESSION.	COMPLETES DISENGAGEMENT FUNCTION STOPS THE COUNTING OF DISENGAGEMENT TIME

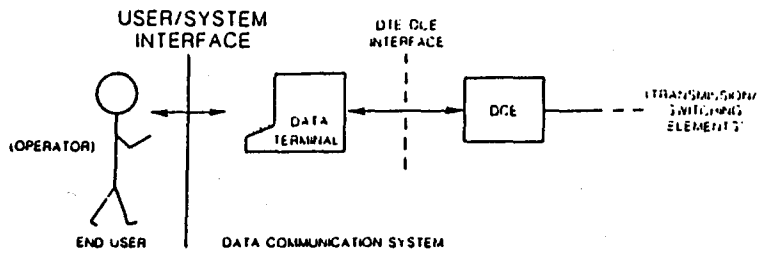

(a) Basic Operator Interface

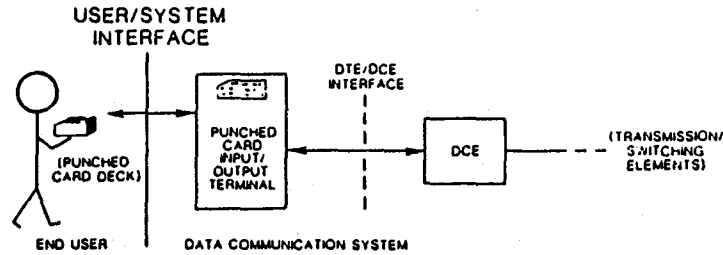

(b) Operator Interface (with Associated Data Medium)

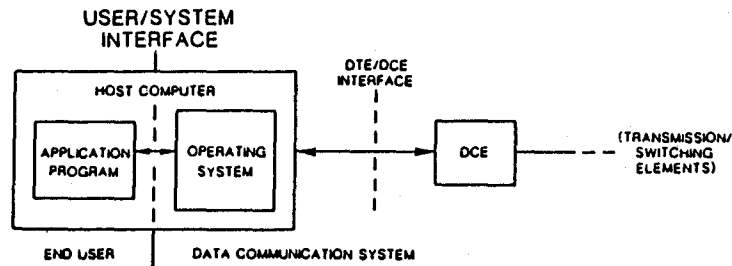

(c) Basic Application Program Interface

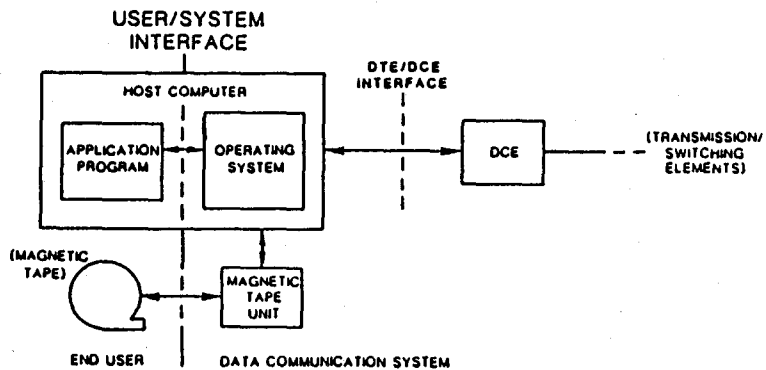

(d) Application Program Interface (with Associated Data Medium)

Figure 4. Interfaces between the end user and the data communication system (ANSI, 1983).

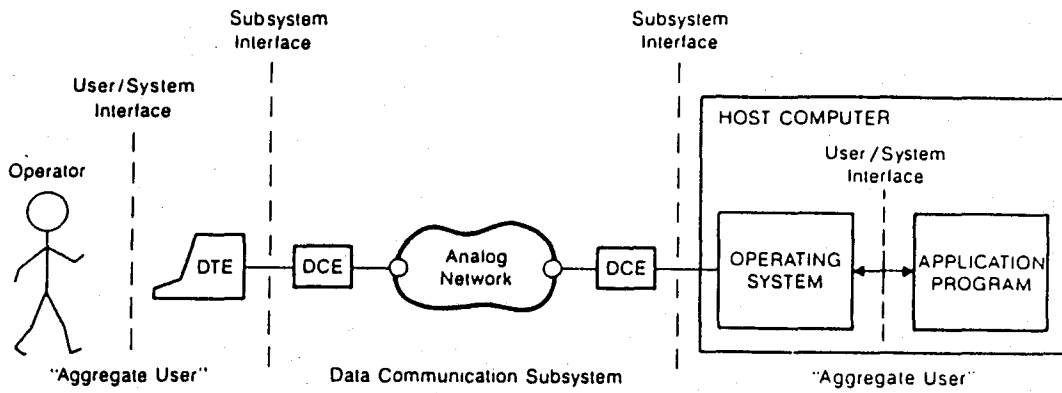

(a) DTE/DCE Interfaces Delimiting a Subsystem

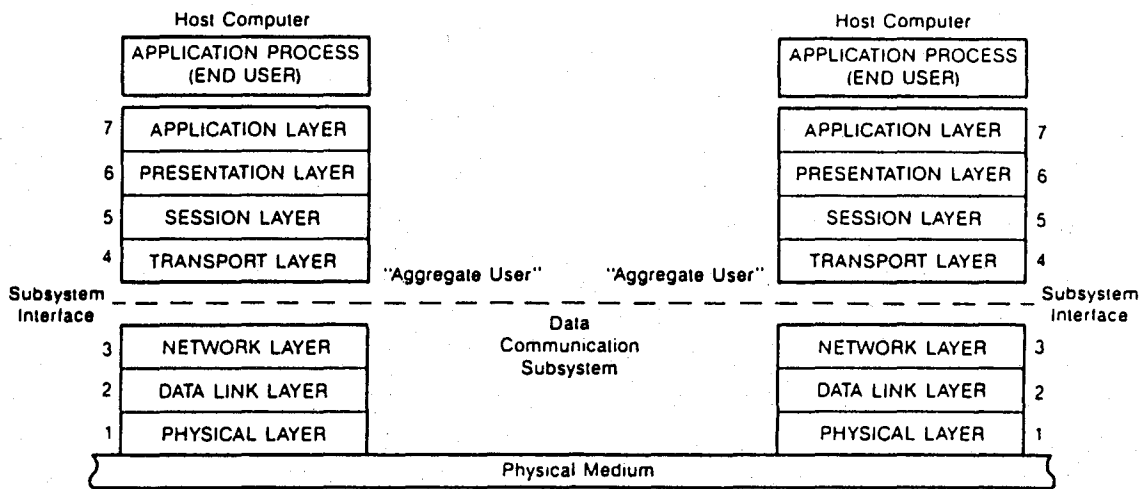

(b) Protocol Layer Boundaries Delimiting a Subsystem

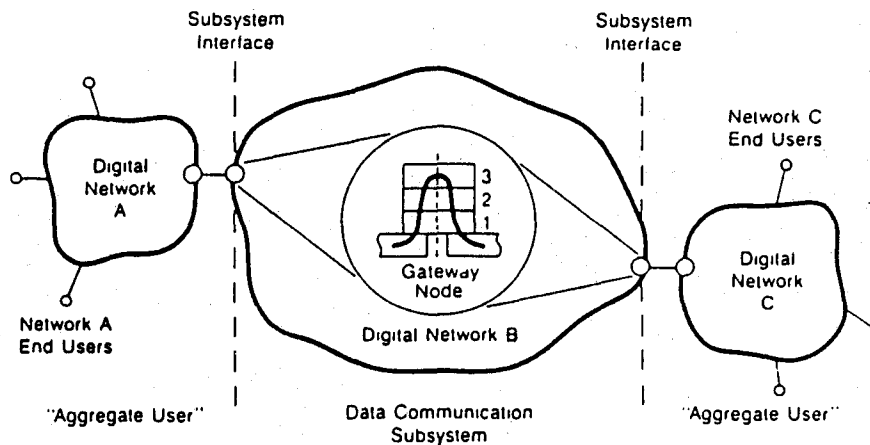

(c) Internetwork Gateway Interfaces Delimiting a Subsystem

Figure 5. Typical subsystem interfaces (ANSI, 1983).

interface events are related to the ANS X3.141 reference events listed in Table 3. The occurrence of these interface events identify system function transitions or system failures, (e.g., receipt of reference event 3, system blocking signal).

As with any experiment, decisions on the population to sample and the appropriate sample size must be made. Miles (1984) presents a detailed discussion on sample size selection and precision for data communication performance measurements. Additionally, Miles (1984) offers a FORTRAN computer program to be used in conjunction with the system performance measurements experiment that calculates the required sample size and independence of population samples.

In summary, ANS X3.102 provides a means of comparing "apples" and "oranges" by defining a "common yardstick" for making and specifying system performance measurements, while ANS X3.141 describes a uniform way to use the yardstick. As discussed in Section 4, this yardstick is very useful for describing ways to measure and quantify the ACTS Low Burst Rate (LBR) system performance.

3. COMMUNICATION SATELLITE END-TO-END SYSTEM PERFORMANCE DEFINITIONS

This section applies the ANS X3.102 and ANS X3.141 data communication system performance specification and measurement ideas detailed in Section 2 to several classes of communication satellites. The first subsection starts by briefly discussing the conventional link budget calculation method of specifying type A and B communication satellite system performance, followed by a discussion of the use of ANS X3.102 for quantifying the end-to-end performance of digital links over these same satellites. The second subsection discusses the use of ANS X3.102 for quantifying the end-to-end communication system performance of time-division multiple-access (TDMA), satellite-switched time-division multiple-access (SS/TDMA), (type C), and demand-assignment multiple-access (DAMA) communication satellites. The third subsection briefly discusses future satellite-augmented ISDN systems and how ANS X3.102 can be used to quantify their end-to-end communication system performance.

3.1 Analog and Digital Link Parameters

The classes of communication satellites considered in this subsection are primarily type A and type B systems as defined in Section 1. These systems

provide simple dedicated point-to-point analog service, dedicated point-to-point digital service, and analog and digital broadcast service. In all of these systems, the satellite serves as a nonregenerative analog repeater. Since none of these systems include any switching or dynamic link control functions, communication system performance is simply equal to transmission link performance.

3.1.1 The Link Budget

The two-step process of link budget and system capacity calculation is the usual method for quantifying communication satellite link performance. The link budget calculation gives the carrier-to-noise density ratio (C/N_0) for analog systems, and the bit energy-to-noise density ratio (E_b/N_0) for digital transmission systems. The system capacity calculation gives the number of voice circuits or video channels an analog system can support and the user bit rate a digital system can support. The appendix gives a detailed discussion and example of these link budget and capacity calculations. The bottom line from these calculations is the communication satellite link performance stated as baseband signal-to-noise ratio (S_b/N_b) and channel capacity for analog systems, and bit error probability (P_e) and transmission bit rate for digital systems.

3.1.2 User-Oriented Performance Measurements

The system link budget and capacity calculations, while straightforward, well understood, and useful to system designers and service providers, are very involved and of little interest to most telecommunication managers or data communication systems users of systems that comprise satellite links. However, end-to-end system performance measurements using ANS X3.102 and ANS X3.141 can be very useful, enabling the managers and users to specify system performance in terms meaningful to them.

ANS X3.102 and ANS X3.141 are primarily intended to be used in measuring the system performance between user interfaces. However, they may also be used to measure the performance of a group of data communication system (or subsystem) elements terminated at digital interfaces. Such a group of system elements could easily be a dedicated or multiple access (nondemand assignment), point-to-point, type A or B digital communication satellite link. The digital

interfaces could be the baseband data input of a multiplexer or the aggregate data input of a satellite earth station modem.

User-oriented system performance concerns for types A and B digital satellite links can be grouped into the three ANS X3.102 performance categories of speed, accuracy, and reliability discussed in Section 2. These categories are quantified by 5 of the 21 ANS X3.102 system performance parameters: Bit Error Probability, Block Error Probability, Block Transfer Time, User Information Bit Transfer Rate, and Transfer Denial Probability (Table 4). These five parameters are selected entirely from the user information transfer function category of ANS X3.102. This selection is reasonable because with dedicated point-to-point digital satellite links users have full time access; thus, Access and disengagement functions are not encountered during normal operation. Also since there are no switching or store-and-forward functions, data entering the system follows only one path; thus, there are no opportunities for user bits or user data blocks to be duplicated, lost, or misrouted. Therefore, the bit/block loss and misdelivery probability and extra bit/block probability parameters are not included.

The four ancillary parameters (attributable to user actions) are also not included. By treating the satellite links as subsystems, there are no direct connections or interactions with the users. It is assumed that data are always available for transmission at rates the links support.

The five applicable performance parameters describe type A and type B communication satellite system performance as follows:

Bit/Block Error Probability

Treating the satellite link as a subsystem, the Bit Error Probability and Block Error Probability are the "raw channel" error probabilities. These are errors observed at the transmission channel interface with no forward error control (FEC) codes or high-level protocols employing error detection and retransmission (ARQ). These error probabilities are the same as the P_e parameter in the link budget and system capacity calculations. A typical design goal for satellite links is a bit error probability of less than 10^{-6} . A block error is declared when one or more bits composing the block are in error.

Table 4. Communication Satellite End-to-end System Performance Parameters

Function	ANS X3.102 Parameters	Type A & B	TDMA	SS/TDMA (Type C)	DAMA
Access	1. Access Time 2. Incorrect Access Probability 3. Access Denial Probability 4. Access Outage Probability				X X X
User Information Transfer	5. Bit Error Probability 6. Bit Misdelivery Probability 7. Bit Loss Probability 8. Extra Bit Probability 9. Block Transfer Time 10. Block Error Probability 11. Block Misdelivery Probability 12. Block Loss Probability 13. Extra Block Probability 14. User Information Bit Transfer Rate 15. Transfer Denial Probability	X X X X X	X X X X X X X X	X X X X X X X X	X X X X X X X X
Disengagement	16. Disengagement Time 17. Disengagement Denial Probability				X
Ancillary Parameters	18. User Fraction of Access Time 19. User Fraction of Block Transfer Time 20. User Fraction of Sample I/O Time 21. User Fraction of Disengagement Time				X X

X = Parameter is used to quantify system performance

Block Transfer Time

Block Transfer Time is the signal propagation delay to the satellite and back (approximately 250 ms) and the modulation time for the block. The propagation time is the same for all types A and B communication satellite systems. The modulation time is the time required to "clock" the data block into the system; it depends on the channel transmission rate and block length.

User Information Bit Transfer Rate

The User Information Bit Transfer Rate, often referred to as throughput, is the user bit rate the system supports. This parameter is the same as the bit rate (R_b) discussed in the appendix. Since there are no store and forward capabilities with type A and B communication satellites, there are no throughput rate conversions; thus, the system input rate equals the system output rate as shown by case 1 of Figure 2.

Transfer Denial Probability

Transfer denial occurs when the transmission quality of the link has degraded to a point that the Bit Error Probability or User Information Bit Transfer Rate is worse than a specified threshold (see Section 2). However, for dedicated point-to-point systems, the User Information Bit Rate is constant and thus would not contribute to transfer denial. Increased P_e due to sun outages and rain fades are the primary cause. Sun outages occur twice a year when the satellite eclipses the sun during the spring and autumn equinox, causing the earth station system noise temperature to rise, thus increasing the P_e . Sun outages last about two to six minutes a day for a two- to four-day period. Rain fades are due to the increased propagation loss and thus increased P_e caused by local rain storms. The limiting case of transfer denial probability is when the system is completely unavailable, i.e., the system is "down" because of an equipment failure. The Transfer Denial Probability can be thought of as the inverse of system availability.

There are distinct advantages in using the ANS X3.102 performance parameters for quantifying type A and B communication satellite system performance. First, by using these parameters, the user is able to evaluate how well these satellite systems meet their requirements, how various configurations or factors (e.g., QPSK modulation vs BPSK modulation) affect the

performance, and how these satellite systems compare with other transmission systems or advanced switching communication satellites. Secondly, these parameters can be used to specify the user's requirements, giving the service provider a starting point for the link design. And finally, these parameters are relatively easy to obtain. If the link budget has been calculated, the Bit/Block Error Probability and User Information Bit Transfer Rate are known. The Transfer Denial Probability can be determined from rain fade models (see Pritchard and Sciulli, 1986) and the Block Transfer Time is known a priori. If the link budget parameters are not available, link performance can be measured by end-to-end system performance experiments similar to those mentioned in Section 4.3.4 and described in ANSI (1987). These experiments are greatly simplified for type A and type B communication satellite systems because the start of block transfer and the end of block transfer are the only reference events that need to be observed.

3.2 TDMA, SS/TDMA, and DAMA System Performance Parameters

Time-division multiple-access, SS/TDMA (type C), and DAMA communication satellite systems operate in a time-division multiplex (TDM) fashion with typically only one carrier presented to a satellite transponder at a time. Each earth station in the network buffers its incoming terrestrial data traffic (or digital signals from digital speech interpolation [DSI] processors), then transmits it to the satellite at a preassigned time in a high-rate burst (120 Mb/s for INTELSAT VI).

The primary advantage of TDMA systems is reduced traveling wave tube amplifier (TWTA) intermodulation distortion from having only one carrier at a time. This allows more efficient use of the transponder and greater down-link power, because the TWTA can be operated closer to saturation. Another advantage is reduced earth station equipment costs for high-volume networks (Campanella et al., 1986).

There are many TDMA systems currently planned and in operation. The simplest, such as INTELSAT V (Trusty et al., 1986), use types A and B communication satellites with global coverage and operate on a preassigned burst time plan (BTP) basis. SS/TDMA systems, such as INTELSAT VI (Trusty et al., 1986), use type C communication satellites with switchable spot coverage antennas. These satellite-switched systems maximize the throughput of the

satellite by interconnecting up-link beams and down-link beams on a real-time, as-needed basis, thus reducing the number of permanently assigned transponders. DAMA systems, such as Satellite Business Systems (SBS) and TELECOM 1 (Feher, 1983), operate on a short-term or real-time BTP assignment mode. These demand-assignment systems further enhance the flexibility and throughput of TDMA systems by changing the system configuration (BTP) in real time to accommodate changes in the network traffic load. This is accomplished by using different preassigned BTPs or generating new BTPs in real time as traffic demands change.

From the user's perspective, all TDMA systems operate on a connection-oriented basis. Once the circuit has been established, the users have full-time access to it and all their information traverses the same path through the system. Detailed information on the various TDMA network architectures, synchronization techniques and operation concerns can be found in Feher (1983).

With these advanced communication satellite systems, the link budget and capacity calculations are still useful to system designers and service providers for designing the system. But, these calculations do not fully quantify the system's performance from the user's perspective. Therefore, using ANS X3.102 and ANS X3.141 becomes very useful for quantifying the end-to-end system performance of these satellite systems.

The following subsection discusses how the 21 ANS X3.102 performance parameters relate to the various TDMA communication satellite systems. Each performance parameter is examined and related to specific system operation events. Table 4 lists the performance parameters deemed applicable to the various TDMA systems discussed. The final selection of the performance parameters for quantifying a particular system is up to the user and his/her specific system performance requirements. However, the end-to-end performance parameters discussed below provide a starting point for quantifying TDMA system performance from the user's perspective and designing system performance experiments around the ANS X3.141 framework discussed in Section 2.

3.2.1 Access

Access methods and times for the various TDMA systems differ. User access to the preassigned TDMA, SS/TDMA, and DAMA systems, that switch between preassigned BTPs to accommodate traffic changes is accomplished by prior

scheduling with the TDMA control center. This can range from a couple of hours to months ahead of when the circuit is needed (Trusty et al., 1986). User access to DAMA systems that generate new BTPs in real time takes a few milliseconds to a few minutes. Therefore, the application of the four access parameters is limited to the DAMA systems generating BTP changes in real time.

Access Time

Access Time for DAMA systems is the time from user issuance of a circuit request to the start of the user's data transmission. The time synchronizing the user's earth station to the network is not included in the Access Time parameter as this is not required each time a new circuit is established. Access Time is one of the most significant parameters for quantifying DAMA system performance.

Incorrect Access Probability

Incorrect Access Probability for DAMA systems is the probability of establishing a circuit with the wrong destination. Transmission errors during the circuit request or generation and distribution of the new BTPs are the mechanisms for establishing an incorrect connection. However, in properly designed DAMA networks, these errors are kept low by the use of error detection and correction techniques. Additionally, if an errored BTP is implemented, the network will lose synchronization and "crash" before the incorrect connection was made. Therefore, due to its low probability of occurrence, the Incorrect Access Probability parameter is not included in the set of DAMA system performance parameters.

Access Denial Probability

Access Denial Probability for DAMA systems is the probability of not establishing a circuit to the desired destination. The primary cause of access denial is lack of system capacity to accommodate an additional circuit. It also occurs if the system is slow in responding to the access request or slow in setting up the circuit, thus exceeding the access denial threshold. Again this would be due to the system operating at or near capacity and thus not having sufficient processor capacity to handle the additional circuit request. With knowledge of the total traffic carried by the system, Access Denial

Probability is a good measure of system capacity and therefore included in the set of DAMA system performance parameters.

Access Outage Probability

Access Outage Probability is the probability of not getting a response from the system when making an access request, i.e., the system is "dead." Any number of hardware and software failures can cause the system to be out. The Access Outage Probability, along with the Transfer Denial Probability discussed below gives an indication of system availability and therefore, is included in the set of DAMA system performance parameters.

3.2.2 User Information Transfer

The user information transfer for all TDMA systems is handled the same way as for any connection-oriented digital communication system. The path through the system for the user's data does not change for the duration of the call. However, the parameters are affected differently by the various TDMA systems, and not all parameters pertain to all systems.

Bit Error Probability

Bit Error Probability is the probability that a transmitted bit will be received in error. This is the same as P_e used in link performance measurements and link budget calculations of types A and B satellite systems. As Bit Error Probability is one of the most common measures of digital communication system performance, it is included in the set of TDMA system performance parameters.

Bit Misdelivery Probability

Bit Misdelivery Probability is the probability that a single user information bit is delivered to the wrong destination. In connection-oriented systems, like the various TDMA systems discussed, user information bits follow only one path through the system. Also, as TDMA systems process the user data in multibit subbursts, it is unlikely that a single bit would be misrouted. Therefore, Bit Misdelivery Probability is not included in the set of TDMA system performance parameters.

Bit Loss Probability

The Bit Loss Probability is the probability that a user information bit entering the system does not reach the intended destination. Again, as TDMA systems are connection-oriented, user information bits have only one path to follow. However, if the TDMA frame-synchronizing unique word (UW) is not detected for a significant number of frames, the local terminal clock will begin to drift, causing the frame boundaries to shift and the TDMA control buffer to overflow, thus losing user data bits. (Feher [1983] discusses unique word detection and probabilities of misses and false alarms.) Also, if the user's system clock is not synchronized to the earth station clock, a "clock slip" can occur. This is when the clock reading data out of a TDMA buffer differs from the clock writing data into the buffer. If the read clock is slightly slower than the write clock, the buffer will eventually overflow and bits will be lost. Additionally, deep fades on the link would cause large blocks of bits to be errored or lost. Bit Loss Probability is included in the set of TDMA system performance parameters.

Extra Bit Probability

The Extra Bit Probability is the probability that a received data bit was a duplicate bit or a bit intended for another destination. Like the Bit Misdelivery Probability and Bit Loss Probability, the Extra Bit Probability is very low for connection-oriented systems. However, if the TDMA frame-synchronizing UW is declared present, when in reality it is not, the TDMA control buffer empties prematurely, thus sending extraneous or duplicate bits. Also, extra bits can be generated by "clock slips." If the read clock is slightly faster than the write clock, the buffer will empty, causing data bits to be clocked out twice and to be counted as extra bits.

The Extra Bit Probability and the Bit Loss Probability give a measure of the UW detector performance and the local earth station clock stability. Therefore, Extra Bit Probability is included in the set of TDMA system performance parameters.

Block Transfer Time

Block Transfer Time for TDMA systems is the time required for data blocks to be fed into and traverse the system. The counting of Block Transfer Time

starts with a user information block crossing the originating user/system interface and ends when the same block crosses the destination user/system interface. Any additional delay beyond the 270 ms propagation delay of a single-hop satellite circuit and the modulation time gives a measure of the additional buffering required in TDMA systems. Therefore, Block Transfer Time is included in the set of TDMA performance.

Block Error Probability

Block Error Probability is closely related to the Bit Error Probability, the probability that a block of user information is received in error. One or more incorrect bits in a block constitute a block error. Therefore, the measurement of Block Error Probability is also included in the TDMA system performance parameters.

Block Misdelivery Probability

Block Misdelivery Probability is the probability that a received user information block was intended for another destination. The primary cause of block misd deliveries are undetected errors in the circuit request address information or BTP generation and distribution. However, errors in the address information would cause an incorrect access and thus be counted in the Incorrect Access Probability calculation. Errors in BTP generation and distribution would allow TDMA bursts or subbursts to be transmitted at the wrong time, misrouting data, and thus misdelivering a user's information block. However, as mentioned for the Incorrect Access Probability parameter, BTP errors would cause the TDMA network to lose synchronization and fail. Therefore, due to its low probability of occurrence, Block Misdelivery Probability is not included in the set of TDMA system performance parameters.

Block Loss Probability

Block Loss Probability for TDMA systems is the probability that an information block does not reach the destination within the specified maximum transfer time due to excessively long transfer delays or lost blocks. The specified maximum transfer time is three times the Block Transfer Time (ANSI, 1983). Since the Block Transfer Time is expected to be relatively constant, the primary mechanism contributing to Block Loss Probability would be

the system misrouting or losing blocks. Misrouting blocks was discussed for Block Misdelivery Probability. Losing blocks would be likely during deep fades on systems not using any form of ARQ protocol. If an ARQ protocol is used, a transmission error can cause a negative acknowledgement (NAK) to be changed to a positive acknowledgement (ACK), thus blocks requiring retransmission would be lost. Other Block Loss mechanisms include hardware and software "crashes" where the system fails momentarily, losing all data in transit. Block Loss Probability is included in the set of TDMA system performance parameters.

Extra Block Probability

Extra Block Probability is the probability that a duplicate block of user information is delivered to the destination user. In systems using an ARQ protocol, an ACK that is lost or changed to a NAK causes the unacknowledged information blocks to be retransmitted. Extra Block Probability is included in the set of TDMA system performance parameters.

User Information Bit Transfer Rate

The User Information Bit Transfer Rate for TDMA systems is defined as the total number of successful bit transfers divided by the time required to transfer them. It is the same as the R_b parameter used to specify the throughput of types A and B communication satellites. Because the TDMA systems are connection oriented, no rate conversion occurs; thus, the input and output data rates are equal as represented by case 1 of Figure 2. Therefore, either the input or output may be examined for measuring the transfer rate. The User Information Bit Transfer Rate is included in the set of TDMA system performance parameters.

Transfer Denial Probability

Transfer denial for TDMA systems is the same as for types A and B communication satellite systems (see Section 3.1.2). It occurs when the transmission quality of the link has degraded to a point where the Bit Error Probability or User Information Bit Transfer Rate is worse than the specified threshold (see Section 2). Increased P_e due to sun outages and rain fades are again the primary cause. Because the User Information Bit Rate is relatively constant, it would not contribute to transfer denial. The limiting case of

transfer denial probability is when the system is completely unavailable, i.e., the system is "down" because of an equipment failure. The Transfer Denial Probability is similar to the Outage parameter used in terrestrial microwave systems and can be thought of as the inverse of system availability. Therefore, it is included in the set of TDMA system performance parameters.

3.2.3 Disengagement

Disengagement, like access, depends on the specific network design and user/system interfaces. Also, like access, disengagement is applicable only to the DAMA systems generating BTP changes in real time.

Disengagement Time

Disengagement Time is the elapsed time from a user issuing a circuit disconnection request to when that user can make another circuit request. Disengagement Time is one of the significant parameters for quantifying DAMA system performance because it gives an indication of how soon a user may establish another circuit.

Disengagement Denial Probability

Disengagement Denial Probability for DAMA systems is the probability that a circuit is not disconnected after the users have issued disengagement requests. The primary causes for disengagement denial are the same as those for incorrect access--errors in the request or BTP generation and distribution. Because these errors are rare due to the network error detection and correction techniques, Disengagement Denial Probability is not included in the set of DAMA system performance parameters.

3.2.4 Ancillary Parameters

The ancillary parameters quantify the impact on system performance due to the user's interaction with the system. The following discussion identifies and estimates the user's influence on system performance, described by the four ancillary performance parameters, for the various TDMA systems.

User Fraction of Access Time

The User Fraction of Access Time is applicable to DAMA systems. It is the time it takes a user to issue an access request and enter the destination

address information (i.e., "dial the number"), and for the destination user to answer. If the users are host computers transferring files, this parameter would be small, thus Access Time would be dominated by the DAMA system operation. But, if the users are human operators with telephones, Access Time would be dominated by the users interactions. The User Fraction of Access Time indicates how much involvement the user has in the system operation. This parameter is included in the set of DAMA system performance parameters.

User Fraction of Block Transfer Time

The User Fraction of Block Transfer Time is the time it takes to generate a block of user's data. If the users are host computers transferring files, the user information blocks are usually ready for transfer; thus, the User Fraction of Block Transfer Time would be small. However, if the users are human operators, where the blocks are assembled at the user's terminal and the block assembly depends on the operator's typing speed, the User Fraction of Block Transfer Time becomes a significant part of the overall Block Transfer Time. Because the User Fraction of Block Transfer Time is largely system independent it is not included in the set of TDMA system performance parameters.

User Fraction of Input/Output Time

The User Fraction of Input/Output Time is the time it takes to enter and extract blocks of user data. For computers transferring files, this parameter would be small. But, with human operators, typing and reading speed would dominate the input/output time. Because this parameter is largely system independent, it is not included in the set of TDMA system performance parameters.

User Fraction of Disengagement Time

The User Fraction of Disengagement Time is also applicable only to DAMA systems and is the time it takes a user to enter a disengagement request. As with the User Fraction of Access Time, it is a measure of how much interaction the user has with the system. Therefore, it is included in the set of DAMA system performance parameters.

3.3 Satellite-Augmented ISDN Systems

Demonstrations of ISDN service using satellite links are currently under way. These are primarily using the satellite as a trunk between ISDN switches or a switch and the local user/network interface. For the broad bandwidth interswitch trunks, simple type A and type B communication satellites, or any of the TDMA systems are usable. For the relatively low bandwidth links between ISDN switches and user/network interfaces, narrow-band TDMA systems using only a part of a transponder (Pritchard and Sciulli, 1986) and very-small-aperture terminals (VSATs) are appropriate.

The next step is for the satellite itself to become an ISDN switch. Advanced satellites, like NASA's ACTS with onboard switching, (see Section 4) would provide this capability. These satellites in a VSAT network would support ISDN user/network interfaces at the basic 2B+D (144 kb/s) channel rate or primary 23B+D (1.544 Mb/s) channel rate. Broadband DAMA satellite systems would provide broadband-ISDN connectivity between ISDN switches, or act as a broadband-ISDN switch for interconnecting high volume-users.

With communication satellite systems incorporated in ISDN, it is useful to examine end-to-end system performance with tools such as ANS X3.102. Work has already begun in this area with CCITT Recommendation G.821 for an end-to-end bit error rate (BER) of 1×10^{-6} on satellite trunks for ISDN service (Potts, 1987). The performance of the B-channels (connection oriented circuit switched) can be quantified by the performance parameters identified for DAMA satellite systems. The performance of the D-channels (packet switched) will require the complete set of 21 performance parameters to fully describe their performance.

End-to-end system performance experiments for these satellite-augmented ISDNs can be designed using the ANS X3.141 framework discussed in Section 2. These experiments would be fundamentally the same as DAMA satellite and ACTS system performance experiments.

4. ACTS OVERVIEW, OPERATION, AND END-TO-END SYSTEM PERFORMANCE DEFINITIONS

The Advanced Communications Technology Satellite (ACTS) is the third phase of the NASA 30/20 GHz program. Phase one was the development of advanced 30/20 GHz communication satellite technologies and laboratory proof-of-concept

(POC) models. Phase two was the development and refinement of these technologies for space applications (Moy, 1986). And phase three, ACTS, is the flight test bed for verifying the technology developments of the first two phases. Some of the technology developments demonstrate are:

Ka-band operation with 30 GHz up-link and 20 GHz down-link radio frequency (RF) components

dual power, 20 GHz, space-qualified traveling wave tube amplifiers (TWTA)

Baseband Processor (BBP) for onboard baseband switching of the user's data traffic

demand assignment multiple access (DAMA) operation

multibeam communication package (MCP) with cross-polarized, scanning, spot beam antennas to facilitate frequency reuse

rain fade compensation via independent up-link and down-link forward error correction (FEC) coding and link power control.

NASA is sponsoring the development and construction of ACTS. NASA will launch ACTS with the space shuttle and provide operational support during a two- to three-year experiment period. ACTS will be available free of charge to private industry, universities, and local, state and Federal Government agencies for conducting experiments and demonstrating the feasibility of its advanced systems.

ACTS is not intended to be a revenue-generating communication satellite. Its primary purpose is to demonstrate new technologies and ideas that may be incorporated in an operational advanced satellite system. The final architecture and protocols of commercial systems may be vastly different from ACTS. However, ACTS will provide a starting point for designing such an advanced communication satellite systems.

ACTS will basically operate as a switched digital communication network. As such, it becomes desirable to quantify its performance from the user's perspective. This will provide a basis for evaluating how a commercial advanced communication satellite system performs from the user's perspective and will help identify the performance impact of the various ACTS technologies. The primary focus of this section is to present a standard method for quantifying ACTS system performance.

The section is divided into three subsections. The first gives a brief system overview and operation description of the ACTS low burst rate (LBR) mode. The second discusses how the 21 ANS X3.102 performance parameters, introduced in Section 2, relate to performance of the ACTS LBR mode. And the third discusses the basic design requirements for an ACTS LBR system performance experiment using the framework of ANS X3.141.

4.1 ACTS Overview and Operation

This subsection provides a brief introductory description of the ACTS LBR system and an overview of its operation. Inukai, et al. (1988), Naderi and Campanella (1988), and Wright (1986) offer additional in-depth information on the capabilities and operation of ACTS.

4.1.1 ACTS LBR System Overview

The ACTS LBR system is a true DAMA digital communication network using a 1-ms TDMA frame format. The network is a star topology with the satellite as the central switching hub and the individual earth stations as the ends. It is a connection oriented. The user's data are sent in packet-like segments with address and control fields, but since there is only one switching node, the packet path does not change from packet to packet. The address and control fields of the packets form an "order wire," functioning like the common channel interoffice signaling systems used by long-haul carriers. Through the order wires, the user's request service, in 64 kb/s increments, from 64 kb/s up to approximately 6.1 Mb/s. Therefore, from the user's perspective the ACTS network behaves more like a circuit-switched network than a packet network.

Another advanced technology feature of ACTS is the multibeam communication package (MCP). Multiple small coverage area (approximately 150 km in diameter) spot and scanning beam antennas with cross polarization are used instead of global or wide area coverage antennas. This allows greater frequency reuse and higher gain antennas on the satellite. Figure 6 illustrates the proposed ACTS coverage area. During each 1-ms TDMA frame, all earth stations requiring service are illuminated. Like true DAMA satellite systems, the ACTS circuit routing and coverage area can be programed in real time to accommodate changes in user traffic demands.

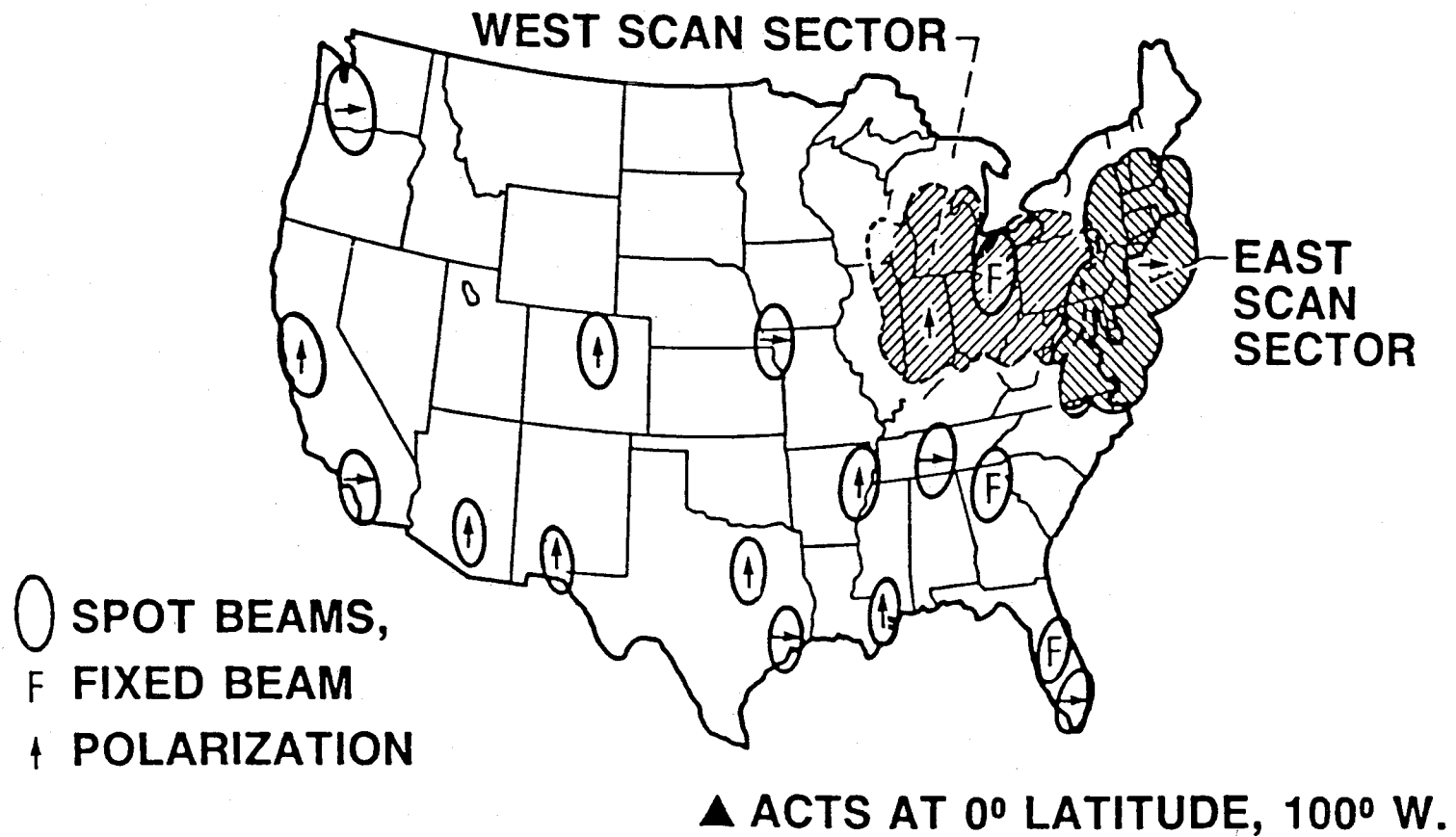

STEERABLE ANTENNA WILL COVER ALL OF UNITED STATES INCLUDING ALASKA & HAWAII

Figure 6. ACTS scan and spot beam coverage.

During each TDMA frame the spot beam (or scanning beam in the scan sector) stops (dwells) on each area with active earth stations. During the dwell, each earth station transmits and receives its user traffic. On the terrestrial side, the earth stations receive a continuous data stream from the users (up to 6.144 Mb/s or 96 equivalent 64 kb/s voice circuits). The earth stations buffer and segment this incoming data into 64-bit-long words. These words are packaged into messages. At a predetermined slot in the TDMA frame, the messages are transmitted in a 110 Mb/s burst. These bursts are received at the satellite, demodulated and demultiplexed back to the 64 kb/s baseband, and stored in the BBP input memory. During the next frame, the contents of the memory are transferred through the BBP routing switch to the appropriate BBP output memory. Then during the third frame, the contents of the BBP output memory are transmitted in a 110 Mb/s burst in a TDM fashion during the appropriate down link spot dwell. Thus, it takes three TDMA frames (3 ms) for the signal to be processed through the satellite. The ACTS system will operate in both point-to-point and point-to-multipoint (broadcast) modes.

Another ACTS technology demonstration is independent rain fade compensation for the up link and down link. This is done with adaptive forward error correction (FEC) coding and burst rate reduction. For example, if a rain fade is detected on the up link, the up link signal is encoded with a rate-1/2 convolutional code and transmitted at a reduced burst rate, thus increasing the link budget margin. When the signal is demodulated on board the satellite, it is decoded and the original baseband bits are recovered. If fade compensation is required on the down link, the signal is encoded on board the satellite and transmitted at a lower burst rate to the destination earth station, again increasing the link budget margin. Since it is unlikely that the originating terminal up link and destination terminal down link will suffer rain fades simultaneously, the signal is only encoded on the link that requires it; the clear link is transmitted uncoded at the normal burst rate.

With onboard signal regeneration, FEC coding, and burst rate reduction, it is possible to support single-hop VSAT-to-VSAT communications. With type A and B communication satellite systems, if a VSAT wishes to communicate with another VSAT, the traffic must first be routed to a large central hub terminal where it is regenerated and retransmitted to the destination VSAT. This involves two satellite hops, thus increasing the propagation delay and making voice

communications difficult (Glen et al., 1976). However, with ACTS, the satellite performs the function of the central hub station, thus reducing the number of hops and facilitating acceptable voice communication.

4.1.2 ACTS LBR System Operation

The ACTS LBR system uses portions of the TDMA frame as order wire channels to carry network control information. Figure 7 shows the flow of this control information through the various TDMA bursts of the up link and down link frames. Figures 8 and 9 show the up link and down link TDMA frame structure in greater detail, illustrating dwell time slot and fade control allocations.

The up link TDMA frame (Figure 8) starts in MCP spot dwell time slot number one with a control burst (CB) from the master control station (MCS). The CB contains the control instructions for the BBP data routing processor (DRP) and outbound order wire information from the MCS to the user earth stations. The CB is transmitted with FEC coding.

Next are the uncoded traffic bursts (UTB's) from the active user earth stations. The UTB's contain the inbound order wire information and the user's data traffic. One UTB per frame is sent from the NASA ground station (NGS) and each active user station. If the NGS or a user station needs fade compensation, the MCS instructs it to move the traffic bursts to the "Pooled Fade Control Slots" shown in Figure 8 (b) and to send it as a coded traffic burst (CTB). These bursts contain the inbound order wire and terminal traffic but are transmitted during the special time slots with rate 1/2 FEC coding and reduced burst rate.

The final burst in the up link TDMA frame is the transmit acquisition burst (TAB) sent from user earth stations first entering the network. The TAB is used for earth station timing acquisition and network synchronization. Like the CB the TAB is also FEC coded.

The down link TDMA frame (Figure 9) starts in MCP spot dwell time slot number one with the order wire burst (OWB) to the MCS. The OWB contains the BBP status messages and an aggregate of the inbound order wire information from all the active user earth stations. The OWB is always sent with FEC coding.

Next is the reference burst (RB) containing the outbound order wire information and tracking error words (TEW's) for each earth station. (The TEW's are used for keeping the earth stations synchronized with the network.)

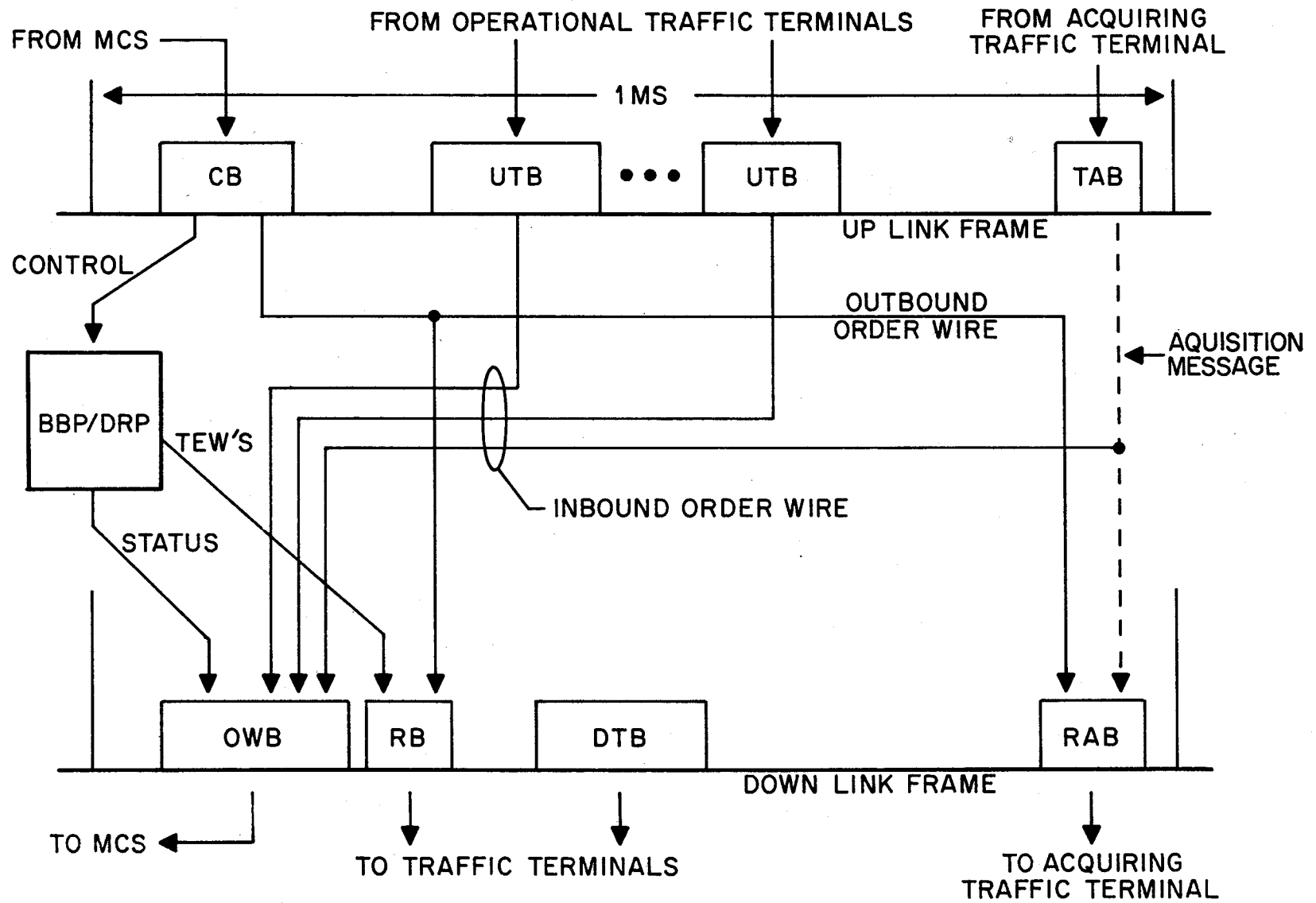

42

Figure 7. Order wire/status/control routing diagram.

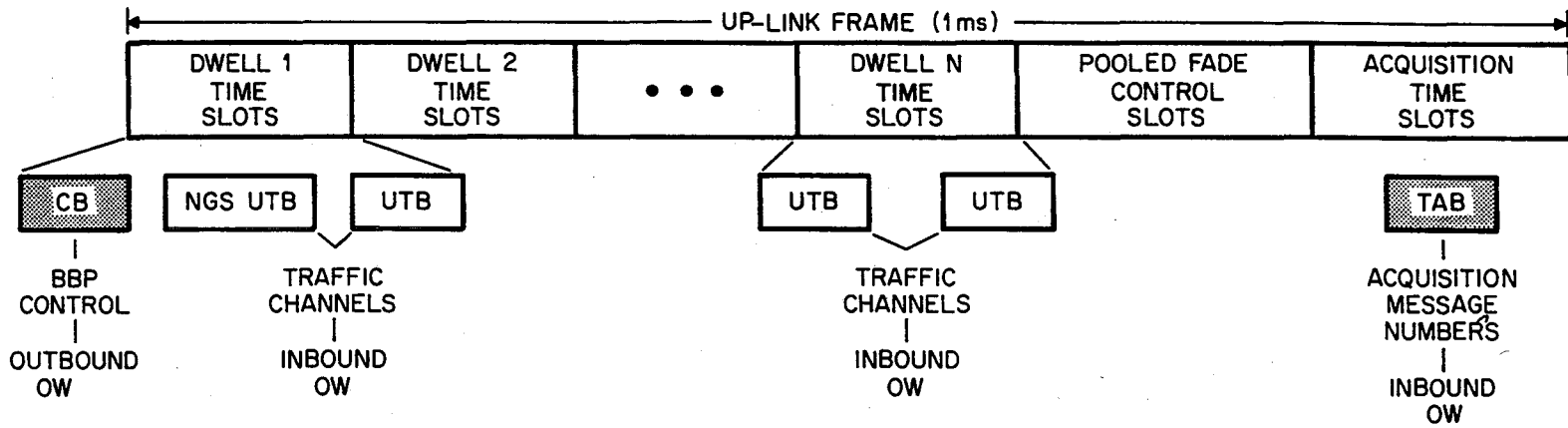

(a) Uncoded Up Link Frame

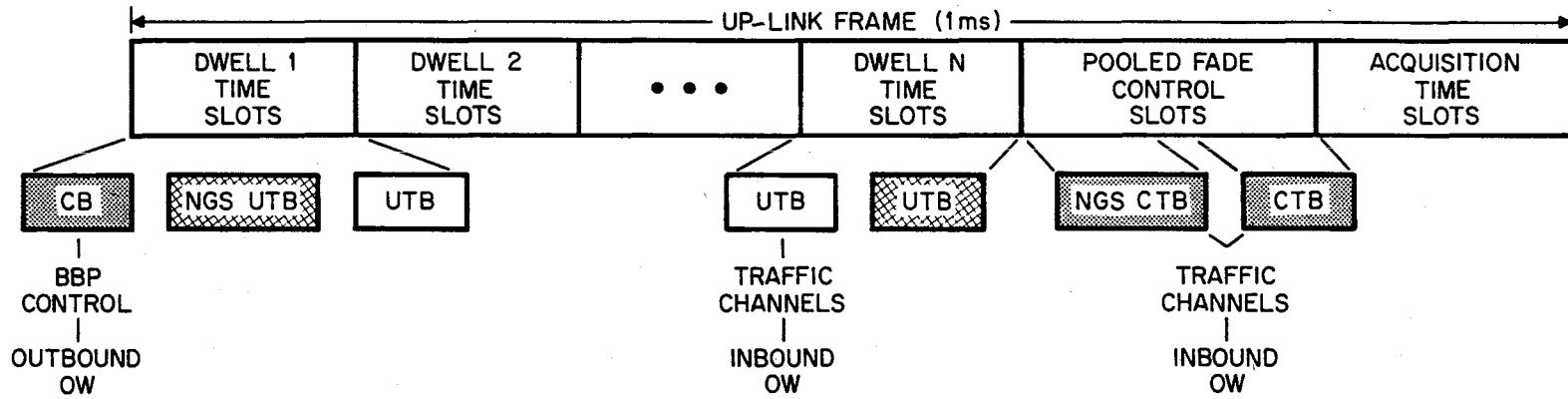

(b) Coded Up Link

 FEC CODED BURST

 MOVED TO FADE CONTROL SLOTS

Figure 8. Up-link TDMA frame structure.

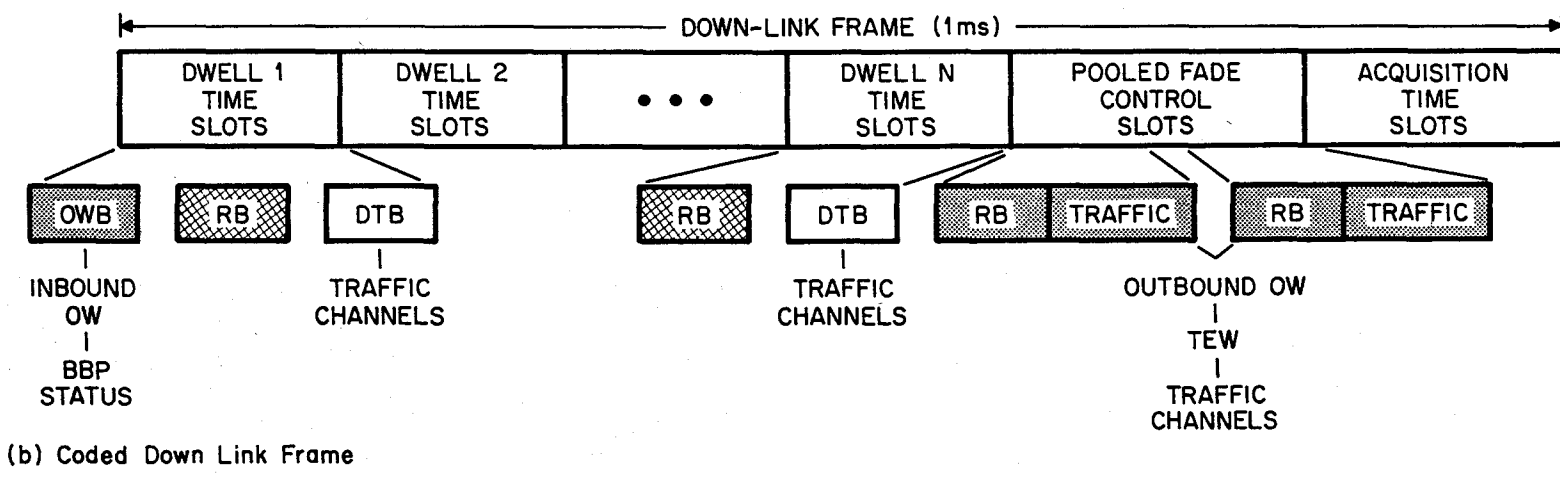
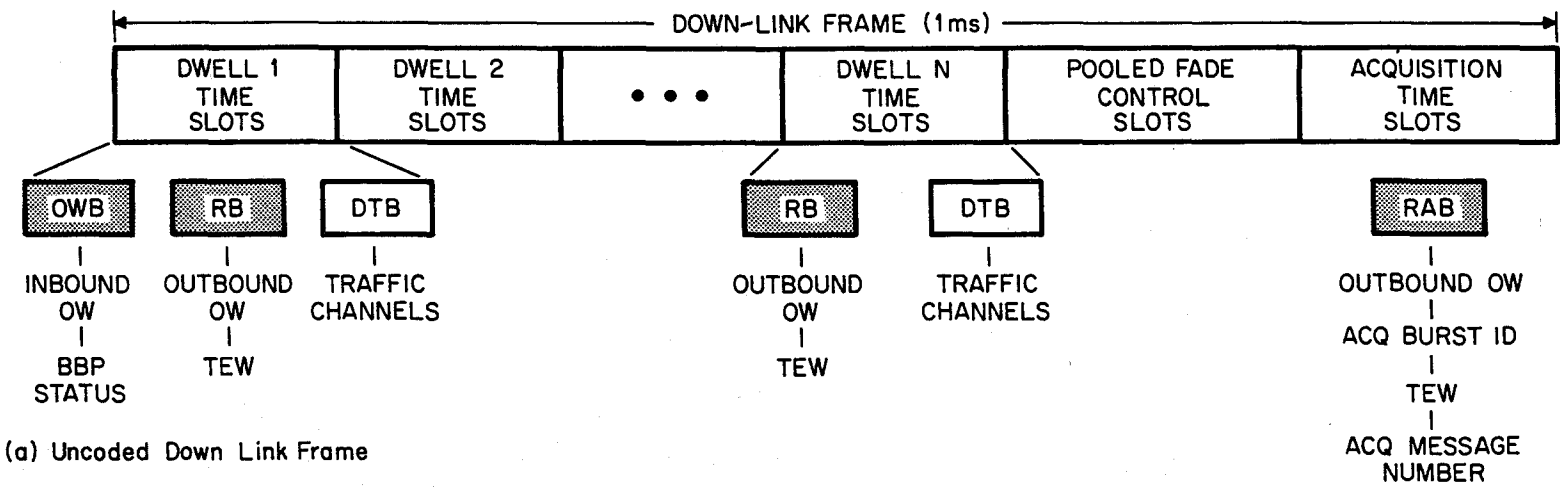

FEC CODED BURST
 MOVED TO FADE CONTROL SLOTS

Figure 9. Down-link TDMA frame structure.

The RB is also FEC coded. Following the RB is the down link traffic burst (DTB) carrying all the down link traffic for that particular dwell area. As shown in Figure 9 (a), there is an RB and DTB for each dwell time slot. As shown in Figure 9 (b), when an earth station in a particular dwell area needs fade compensation, its coded traffic is appended to the RB and moved to a down link fade control slot. The uncoded traffic for the other user earth stations is transmitted in their normal time slots.

The final down link burst is the receive acquisition burst (RAB). This is transmitted to user earth stations first entering the network. Like the up link TAB, the RAB is used for earth station timing acquisition and network synchronization. The RAB is also FEC coded.

The ACTS LBR TDMA frame is divided into 1728 slots or words, each 64 bits long, equating to the 110.592 Mb/s transmission rate. Every 75th frame (every 75 ms) is declared a superframe. The MCS sends one outbound order wire message per frame, user earth stations send one inbound order wire message per superframe.

Figure 10 shows the time sequence for establishing, using, and disconnecting a 64 kb/s ACTS LBR circuit. The sequence begins with a user signaling the originating user earth station that he/she wishes to place a call. The originating user's earth station transmits, via the inbound order wire, a circuit request message containing the destination user's earth station identification number and the circuit identification number. The circuit identification number is used to identify the circuit throughout its existence and consists of the terrestrial channel number and the originating user's earth station identification number. The circuit request message also has a station-to-station communications field for terrestrial circuit signaling information.

After receiving and processing the circuit request message, the MCS allocates up link and down link capacity and assigns TDMA frame slots. It also stores this assignment information in an active circuit file listing the current resources allocated to each circuit in the network. It then sends a circuit assignment message via the outbound order wire to the circuits originating and destination earth stations. This message contains the circuit identification number, destination terminal number, up link and down link slot assignments, and down link portion of the station-to-station terrestrial circuit signaling information.

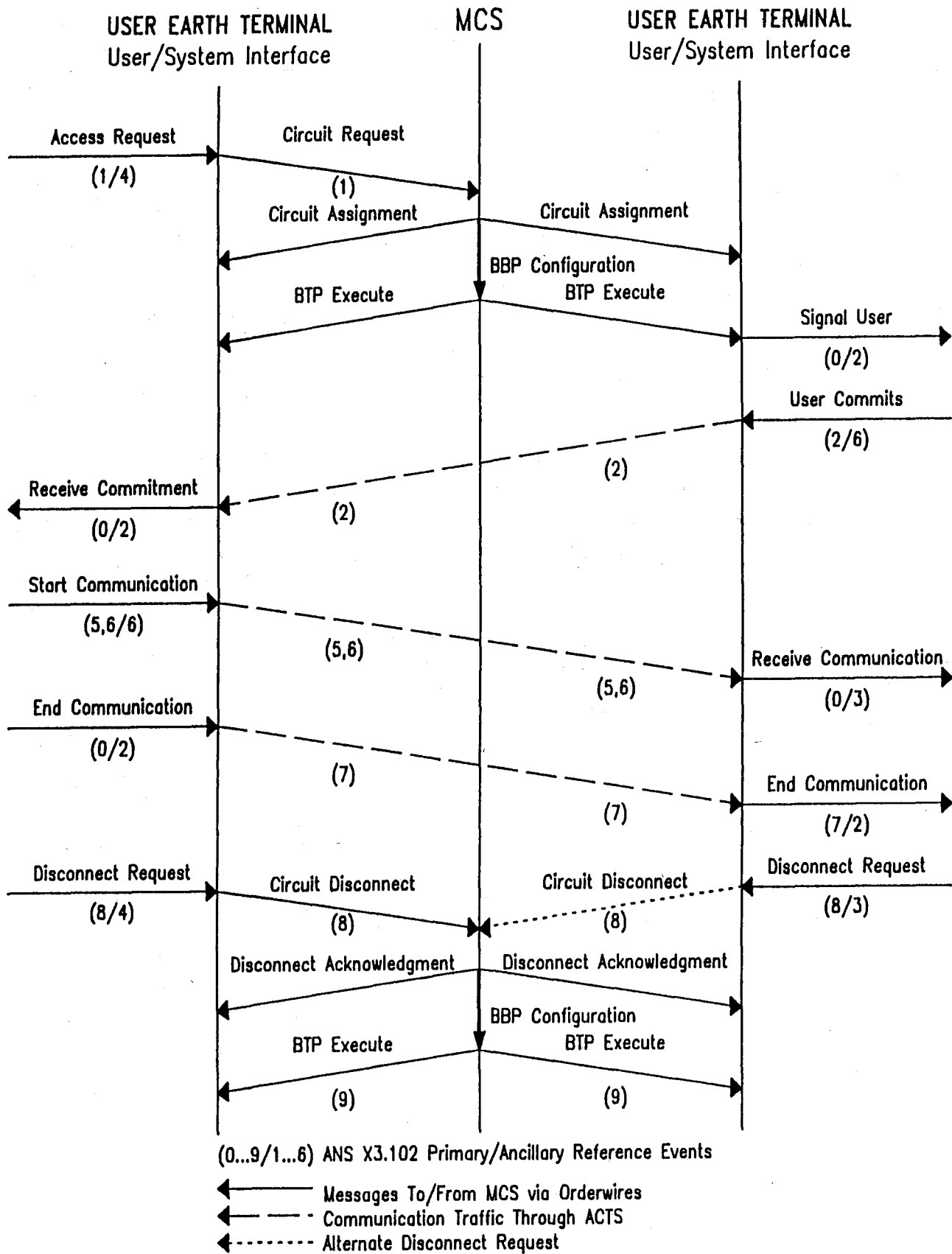

Figure 10. Typical ACTS LBR system communication session.

To accommodate the additional channels, the TDMA BTP must be modified. The MCS initiates these modifications by sending outbound order wire burst assignment and burst slot move messages to the affected earth stations. Also, the BBP is instructed to update its BBP traffic route time plan (BBPTP), rerouting the reassigned bursts. The modified BTP and BBPTP are stored until the MCS issues the BTP execute command, thus initiating the changes and establishing the new circuits. If the MCS is unable to complete the request no circuit assignment message is sent, the originating user will eventually abandon the call if it is not connected.

The users initiate the circuit disconnect process by signaling their earth station. The disconnecting earth station issues a circuit disconnect message, containing the circuit identification number, via the inbound order wire. The station then waits for a disconnect acknowledgement from the MCS before disconnecting the circuit.

When the MCS receives the circuit disconnect request, it checks the active circuit file for the circuit identified. If the circuit is listed, the disconnect message is valid and the MCS proceeds with the disconnect process. The MCS sends a disconnect acknowledgement message to both earth stations carrying the circuit, instructing them to disconnect the circuit. If the circuit listed in the circuit disconnect message is not in the MCS active circuit file, the message is discarded. If the MCS needs the TDMA frame space to accommodate new circuit requests, it will develop and distribute a new BTP. If it does not need the frame space freed by the disconnect request, the current BTP is not changed.

Large trunk circuits are established by making multiple requests for 64 kb/s circuits. Each request contains the same circuit connect parameters but has a unique circuit identification number. The trunk is not available until all the circuit assignments have been received and implemented. A similar procedure applies to disconnecting the trunk. Disconnect requests for each 64 kb/s circuit comprising the trunk is processed separately.

Broadcast connections are similarly established, except the circuit request messages contain the same circuit identification number but with different destination station numbers. As with the trunk circuits, the broadcast connection cannot be used until all the circuits have been established. Disengagement is more involved. If a nonoriginating user wishes to disconnect,

that circuit is disconnected but the remaining circuits are still active. However, if the originating user disconnects, all circuits are disconnected.

4.2 ACTS LBR System Performance Parameters

In order to use the ANS X3.102 performance parameters to quantify the performance of advanced communication satellite systems such as ACTS, the relationship and applicability of the 21 ANS X3.102 performance parameters to the satellite system operation must be investigated. As was done in Section 3 for the various TDMA satellite communication systems, each ANS X3.102 performance parameter is examined and related to the ACTS LBR mode operation. Included in this discussion is the examination of how and to what extent various mechanisms within the ACTS LBR system affect the estimates for the performance parameters. Table 5 identifies the performance parameters deemed applicable to the ACTS LBR system.

4.2.1 Access

The exact method of user access to the ACTS LBR system depends on the specific user/system interface used. The originating user requests a connection then waits until the circuit is established and the destination user has answered before transmitting any data. Since the ACTS LBR system is a true DAMA satellite system generating new BTPs in real time, access function performance is of interest.

Generic descriptions of the four performance parameters associated with the access function are given in Section 2, Seitz and Grubb (1983), and ANSI (1983).

Access Time

Access Time for the ACTS LBR system is the elapsed time from a user issuing a service request to the start of the user's data transmission. It is assumed that the user's earth station is synchronized to the network; thus, only the call request must be processed. As described in Section 4.1.2, the circuit is available for use only after the new BTP has been implemented. If many circuit requests must be processed, the MCS may not issue a new BTP until all of the requests can be served. Thus, Access Time may vary with the network traffic load, the number of connection/disengagement requests, and the number of

Table 5. ACTS LBR System Performance Parameters

Function	ANS X3.102 Parameters	ACTS LBR Parameters
Access	1. Access Time 2. Incorrect Access Probability 3. Access Denial Probability 4. Access Outage Probability	X X
User Information Transfer	5. Bit Error Probability 6. Bit Misdelivery Probability 7. Bit Loss Probability 8. Extra Bit Probability 9. Block Transfer Time 10. Block Error Probability 11. Block Misdelivery Probability 12. Block Loss Probability 13. Extra Block Probability 14. User Information Bit Transfer Rate 15. Transfer Denial Probability	X X X X X X X
Disengagement	16. Disengagement Time 17. Disengagement Denial Probability	X
Ancillary Parameters	18. User Fraction of Access Time 19. User Fraction of Block Transfer Time 20. User Fraction of Sample I/O Time 21. User Fraction of Disengagement Time	

X = Parameters applicable to the ACTS LBR system

stations requiring FEC coding (FEC coding requires additional BTP changes). Access Time is one of the most significant ACTS LBR system performance parameters and is therefore included in the set of ACTS LBR system performance parameters.

Incorrect Access Probability

Incorrect Access would occur in the ACTS LBR system if there are undetected bit errors in the inbound order wire address information to the MCS or the BBPTP information from the MCS to the DRP. However, because cyclic redundancy codes (CRC) are used within the order wire and control information fields, undetected errors would be few. When an error is detected, the request is ignored and access is denied. Therefore, because of this low probability of occurrence and the difficulty in measuring the number of incorrect accesses, the Incorrect Access Parameter is not included in the set of ACTS LBR system performance parameters.

Access Denial Probability

Access denial for the ACTS LBR system would occur when the system is operating close to capacity and thus would not be able to support an additional circuit. In this case the BTP may not be able to accept any additional user traffic, or the source or destination earth stations might not be able to accommodate the extra bandwidth required for an additional circuit. System capacity is reduced and thus Access Denial Probability is increased if any earth stations in the particular dwell area require fade compensation. Also, if the destination earth station does not have any terrestrial circuits available, it will block the call (by issuing a disengagement request).

Minor system/component failures would also cause Access Denial, e.g., the destination earth station is "down" or not yet synchronized to the network. Additionally, bit errors on the inbound order wire during a capacity request would cause the MCS to ignore the request, thus denying access.

Access Denial due to excessive delays is possible. The threshold for access denial, as shown in Figure 1, is defined as three times the mean system Access Time. Therefore, under excessively heavy traffic conditions the call request processing time of the MCS may exceed this threshold, thus denying

access. Also, if the MCS determines that the call cannot be completed, the request is discarded.

Measuring the Access Denial Probability is useful for determining the true system capacity and identifying hardware and software bottle necks. Therefore, it is included in the set of ACTS LBR system performance parameters.

Access Outage Probability

Access outages in the ACTS LBR system can occur for a number of reasons: the originating user's earth station is "down;" the capacity request messages are rejected due to higher channel error rate from a heavy local rain storm; the MCS is not operational; or the satellite is scheduled for some other experiment and thus not available for LBR use.

Ideally, in a fully operational system, worst-case values for the Access Outage Probability would be in the range of 10^{-1} to 10^{-3} (Seitz and Grubb, 1983). In a nonrevenue generating system such as ACTS, the Access Outage Probability is expected to be higher because of its experimental nature; however, the consequences of access outage are not as severe as for revenue generating networks. Therefore, Access Outage Probability is not included in the set of ACTS LBR system performance parameters.

4.2.2 User Information Transfer

The user information transfer for the ACTS LBR system is like other connection oriented digital communication systems. The path through the system for the user's data does not change for the duration of the call.

The ANS X3.102 block-oriented user information transfer parameters are associated with transporting user defined information units. Normally users define block lengths that are compatible with their data processing equipment or higher layer protocols, regardless of how the communication system packages their data. However, because the ACTS LBR system handles all data in 64-bit increments, when looking at system level performance, a block is defined as 64 user bits. This does not severely limit the usefulness of these performance parameters as most common user defined blocks are integer multiples of 64 bits.

Generic descriptions of the 11 performance parameters associated with the user information transfer function are given in Section 2 and in Seitz and

Grubb (1983). These bit and block transfer parameters are described mathematically in ANSI (1983).

Bit Error Probability

The Bit Error Probability is the same parameter that is used in link performance measurements and link power budget calculations of types A and B satellite systems. It is a function of the channel signal-to-noise ratio and transmission rate (see Appendix). The ACTS LBR system has a Bit Error Probability design goal of 10^{-6} . Because Bit Error Probability is one of the most common measures of digital communication system performance it is included in the set of ACTS LBR system performance parameters.

Bit Misdelivery Probability

In connection oriented systems, such as ACTS, once a user information bit enters the system it has only one path to follow and thus will reach the desired destination. Also, because the ACTS LBR system handles the user data in 64 bit blocks, it would be very unlikely that a single bit would be misrouted. Therefore, Bit Misdelivery Probability is not included in the set of ACTS performance parameters.

Bit Loss Probability

Again, once a user information bit enters the system it has only one path to follow. However, if the user's system clock is not synchronized to the local earth station clock, or the earth station clock is not synchronized with ACTS, a "clock slip" can occur. If the read clock is slightly slower than the write clock, the buffer will eventually fill and lose bits. Additionally, deep fades on the link would cause large blocks of bits to be errored or lost, thus contributing to the value of this parameter.

Even though the probability of losing a bit in the ACTS LBR system is low, Bit Loss Probability is included in the set of system performance parameters. Coupled with the Bit Error Probability, the Bit Loss Probability gives a good indication of the transmission link performance and the systems immunity to fades.

Extra Bit Probability

Like the Bit Misdelivery Probability and Bit loss Probability, the Extra Bit Probability is very low for connection oriented systems. However, extra bits can be generated by "clock slips." If the earth station's terrestrial interface elastic buffer read clock is slightly faster than the write clock, the buffer will empty, causing data bits to be clocked out twice and counted as extra bits.

Even though the probability of receiving an extra bit in the ACTS LBR system is low, the Extra Bit Probability is included in the set of system performance parameters.

Block Transfer Time

Block Transfer Time counting starts when the first bit of a user information block crosses the originating user/system interface and ends when the same block crosses the destination user/system interface. Block Transfer Time is one of the significant ACTS LBR performance parameters and therefore included in the set of parameters.

Block Error Probability

Due to the block processing nature of ACTS, if a bit error occurs, then by definition a block error also occurs. Therefore, the measurement of Block Error Probability is also included in the ACTS LBR system performance parameters.

Block Misdelivery Probability

The main causes for block misdelivery in the ACTS LBR system are errors in the destination address information or switch control commands. These would be undetected errors in the destination address field of the originating station's inbound order wire or errors in the control link from the MCS to the BBP's DRP. Errors in the BBP control link would cause the BBP to misroute the data, thus contributing to Block Misdelivery. However, errors in the address information would cause an Incorrect Access and thus be counted in the Incorrect Access Probability calculation.

The probability of undetected errors in the order wire address field or BBP control link are very low because of the CRC and FEC coding. Therefore, the

Block Misdelivery Probability of the ACTS LBR system is expected to be low. Because of this and the difficulty of collecting enough data to calculate the probability with a high degree of reliability, the Block Misdelivery Probability is not included in the set of ACTS LBR system performance parameters.

Block Loss Probability

The primary mechanism contributing to Block Loss Probability would be misrouted or lost blocks. Block loss would be possible during deep transmission link fades. Since the ACTS LBR system does not use any form of ARQ protocol, blocks transmitted during a deep fade would be lost. Additionally, if the users are using an ARQ protocol and a transmission error causes a NAK to be changed to an ACK, any blocks requiring retransmission would be lost. Other Block Loss mechanisms include hardware and software "crashes" where the system fails momentarily, losing all data in transit.

The Block Loss Probability for the ACTS LBR system is expected to be low, with the main cause being transmission fades. Block Loss Probability is an easy parameter to measure and therefore is included in the set of ACTS LBR system performance parameters.

Extra Block Probability

Because the ACTS LBR system is connection oriented and does not use any form of ARQ protocol, there is little chance for extra blocks to be generated by the system. One probable case, however, would be if the BBP's output memory was read twice before being overwritten with new data. A more likely cause would be a user employing an ARQ protocol where an ACK is lost or changed to a NAK, causing the unacknowledged, but error free information blocks to be retransmitted.

Since the likelihood of the ACTS LBR system generating an extra block is low and concerns about the performance of user's ARQ protocol are outside the ACTS LBR system, the Extra Block Probability is not included in the set of ACTS LBR system performance parameters.

User Information Bit Transfer Rate

For the ACTS LBR system the User Information Bit Transfer Rate is the basic user rate of 64 kb/s, where the input rate and output rate are equal as represented by case 1 of Figure 2. Therefore, User Information Bit Transfer Rate is included in the set of ACTS LBR system performance parameters.

Transfer Denial Probability

Transfer Denial for the ACTS LBR system occurs when the transmission quality of the link has degraded to a point where the Bit Error Probability or User Information Bit Transfer Rate are worse than a specified threshold. ANSI (1983) defines this threshold for the Bit Error Probability as the fourth root of its specified value, and for the User Information Bit Transfer Rate as one third of its specified value. Sun outages and rain fades cause the Bit Error Probability to increase, thus contributing to transfer denial. The limiting case of transfer denial is when the system is completely unavailable, i.e., the system is "down" due to equipment or software failure. Transfer Denial Probability can be thought of as the inverse of system availability. Because system availability is often used to specify communication satellite system performance, Transfer Denial Probability becomes a valuable parameter and is therefore included in the set of ACTS LBR system performance parameters.

4.2.3 Disengagement

The disengagement function for the ACTS LBR system is the same as for other connection oriented data communication system. Generic descriptions of the two performance parameters associated with the disengagement function are given in Section 2 and in Seitz and Grubb (1983). These parameters are described mathematically in ANSI (1983).

Disengagement Time

The counting of Disengagement Time for the ACTS LBR system starts when users signal their earth station that they wish to disengage the call. The user's earth station then issues a Circuit Disconnect message to the MCS via the inbound order wire. The MCS in turn issues a Disconnect Acknowledgment to the earth stations via the outbound order wire. The counting of Disengagement Time ends when the users issue another access request. If there are many

circuit requests, the MCS may not issue a new BTP until all the requests are processed; thus, Disengagement Time may vary with the network traffic load, the number of connection/disengagement requests, and number of terminals requiring FEC coding. Disengagement Time is a significant performance parameter relating to the ACTS LBR system performance. Therefore, it is included in the set of ACTS LBR system performance parameters.

Disengagement Denial Probability

Disengagement denial for the ACTS LBR system could occur due to transmission bit errors during a Circuit Disconnect request or Disconnect Acknowledgment. If the MCS receives an invalid Circuit Disconnect request, i.e., the circuit identified in the request is not on the active circuit list, the request is ignored. The earth station issuing the request will repeat the disengagement request if it does not receive a Disconnect Acknowledgment within a specified time. During deep fades, several Circuit Disconnect requests could be issued before the MCS acknowledges. Thus, there is the possibility that a Disengagement Denial would be declared due to excessive request processing delay.

Because the ACTS LBR system uses CRCs on the order wire commands and FEC coding during fades, Disengagement Denial Probability would be insignificant. Therefore, Disengagement Denial Probability is not included in the set of ACTS LBR system performance parameters.

4.2.4 Ancillary Parameters

Because these parameters rely entirely on the user, they are not included in the set of ACTS LBR system performance parameters. This is not to imply that they are unimportant. An estimate of their impact on system performance is useful for identifying performance problems and developing methods to improve the systems ease of use. The following discussion identifies and roughly estimates some of the user's influence on system performance for the four ancillary performance parameters.

User Fraction of Access Time

The User Fraction of Access Time for the ACTS LBR system is the time it takes the originating user to input the destination address information

(i.e., "dial the number") and destination user to answer. This can take a significant amount of time as the ACTS LBR system uses a "four-way handshake" protocol to establish a circuit. If the users are host computers transferring files, this parameter would be small and Access Time would be dominated by the ACTS LBR system. If the users are human operators with telephones, the User Fraction of Access Time would be the dominant portion of Access Time.

User Fraction of Block Transfer Time

If the users are host computers transferring files, the user information blocks are ready for transfer; thus, the User Fraction of Block Transfer Time would be very small. If they are human operators, and the user information blocks are assembled at the user's terminal, the block assembly depends on the operator's typing speed. Thus, the User Fraction of Block Transfer Time can become a significant part of the overall Block Transfer Time.

User Fraction of Input/Output Time

With computers transferring files, this parameter would be small. However, with human operators, typing and reading speed would dominate the input/output time.

User Fraction of Disengagement Time

Once a user has issued a disconnect request, the ACTS LBR system processes the request and disengages the circuit. The only user dependency is how quickly the disengagement request is entered into the system.

Table 5 identifies the system performance parameters applicable for quantifying the ACTS LBR system performance. The parameters not deemed applicable describe relatively rare system performance outcomes, and typically require long observation periods and more elaborate measurement equipment to gather enough data to estimate the parameter with high confidence. In many cases the effects of these rare events also affect common system performance outcomes, e.g., Bit Error Probability, and are thus already accounted for. This is not to imply that only the parameters identified are useful for quantifying system performance. With enough resources (time, money, personnel), measurement experiments using all 21 ANS X3.102 parameters could be conducted.

4.3 ACTS System Performance Experiment Design Considerations

Two ANS X4.141 measurement objectives are proposed for an ACTS LBR system performance experiment: absolute performance characterization (i.e., determine the system performance baseline); and analysis of factor effects (i.e., determine how different system configurations affect the overall system performance). Table 6 lists some of the ACTS LBR system factors (system configurations) and their levels that could be measured. The most significant factors are the different data rates, the effect of the fade compensation, and performance as a function of traffic load.

4.3.1 ACTS User/System Interfaces

The first task when designing a user-oriented system performance experiment is to identify the user/system interface. Figure 11 illustrates the basic ACTS LBR user/system interfaces options. The primary interface point is the ACTS Central Office (CO) equipment, which looks and functions like a terrestrial telephone system central office. The specific user interface data rates and protocols depend on the interface options implemented in the ACTS CO, but the basic intent is for ACTS to appear to the users like a terrestrial telephone system. The user goes "off hook" (or instructs their modem to go off hook), receives a "dial tone," dials the number, hears a "ring-back" from the destination, and waits for the destination user to answer.

The physical difference between ACTS and terrestrial telephone systems ends at the user/system interface. As shown in Figure 11, the host computer in the earth station performs the control functions in place of a human operator or stand-alone computer controlling the CO equipment. This host maintains the CO's routing table, receives the local user busy indications from the CO, receives satellite trunk requests from the CO, and formats the inbound order wire requests to the MCS. The host also receives BTP control, signaling, and traffic routing instructions from the MCS via the outbound order wire.

4.3.2 ACTS LBR System Level Reference Events

Another task when designing an ACTS LBR system performance experiment is to map the ACTS LBR system operation into the nine ANS X3.141 system-independent reference events discussed in Section 2. This facilitates the identification

Table 6. ACTS Performance Factors and Levels

<u>Performance Factor</u>	<u>Levels</u>
Data Rate	LBR Mode: 64 kb/s 1.544 Mb/s (T1) 6.312 Mb/s (T2)
Rain Fade Conditions	Clear Weather: With FEC Without FEC Rainy Weather: With FEC Without FEC
User Locations	Same Scan Sector, Same Spot Beam Same Scan Sector, Different Spot Beam Different Scan Sector
Terminal Types	MICRO-1 ACTS Terminal (VSAT) MICRO-2 ACTS Terminal (VSAT) LBR-1 ACTS Terminal LBR-2 ACTS Terminal
Terminal Protocols	ISDN Packet Other
Traffic	Busy Hour: Voice only Data only Mixed voice and data Non-Busy Hour: Voice only Data only Mixed voice and data

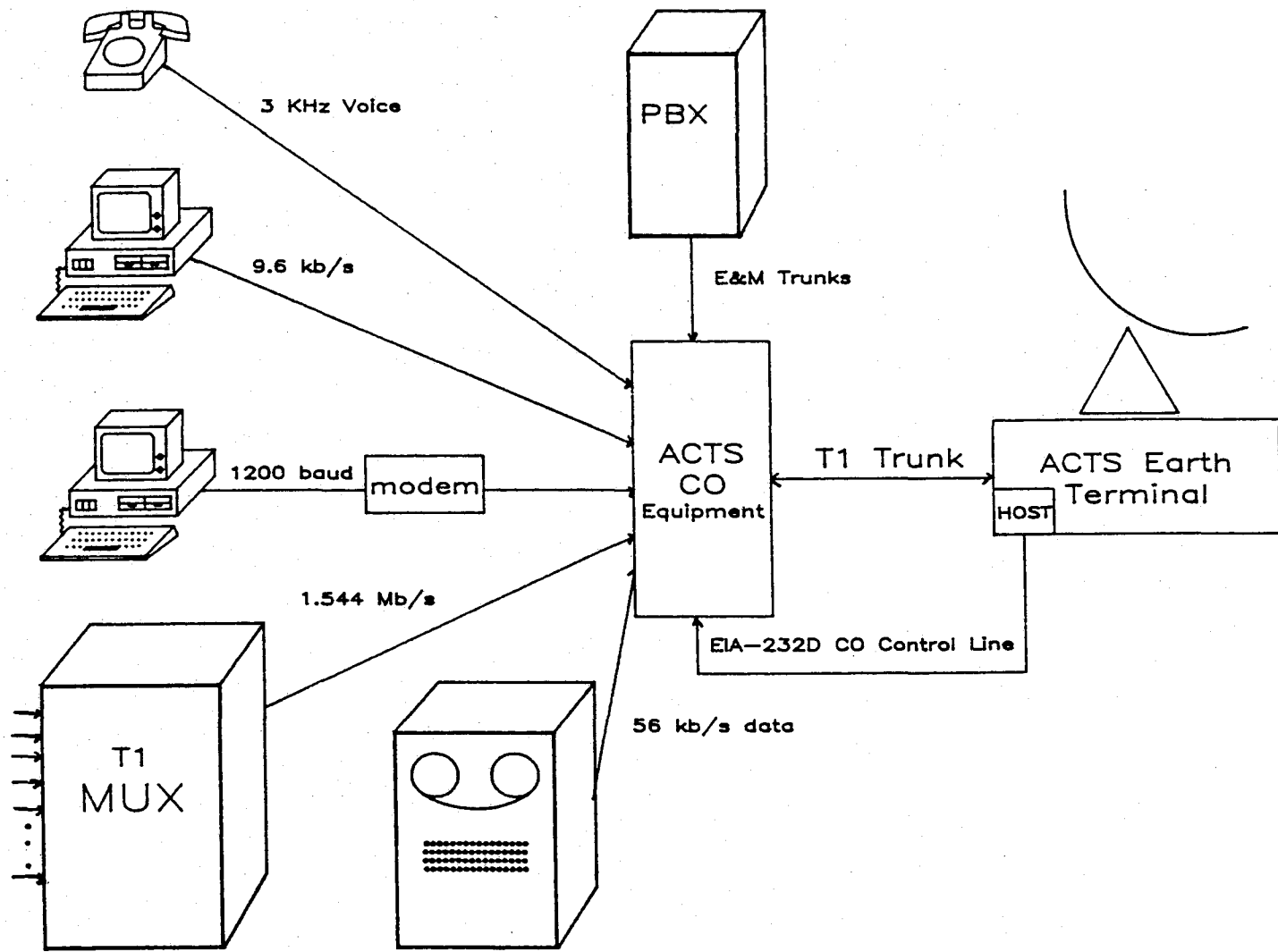

Figure 11. ACTS terrestrial interfaces.

and recording of the performance-significant interface events for the data extraction part of the ANS X3.141 measurement process. The following is a mapping of the ACTS system operation into these reference events.

Access Request

An Access Request occurs when the originating user signals the earth station that he/she wishes to call another user. The originating user's earth station then formats and transmits a circuit request message, which contains the destination address, via its inbound order wire to the MCS. A circuit is established following the process outlined in Section 4.1.2. The occurrence of an access request signifies the start of the access time measurement.

Nonoriginating User Commitment

The originating user receives a "ring-back" signal while the destination user is being signaled. The Nonoriginating User Commitment occurs when the nonoriginating (destination) user answers the call. Incorrect access is eliminated as a possible access outcome when the desired destination user answers the call.

System Blocking Signal

System Blocking Signals are issued only when the originating user's earth station cannot accommodate the call. The originating user is not notified if the call is blocked within the ACTS LBR system (destination earth stations or MCS). If the MCS cannot process the call request, the request is ignored and the originating user will eventually abandon the call.

User Blocking Signal

A User Blocking Signal is issued when the destination user is either busy (the originating user receives a "busy tone") or does not answer. As defined in ANSI (1983), a call attempt blocked by the destination user is excluded from the system performance measurements.

Start of Block Input To System

The Start of Block Input to System occurs when the first bit of user information crosses the originating user/system interface. The measurement of access time is stopped when this event occurs.

Start of Block Transfer

Because the ACTS LBR system is connection-oriented, the Start of Block Transfer coincides with the Start of Block Input to the system. The measurement of block transfer time is started when this event occurs.

End of Block Transfer

The End of Block Transfer occurs when the last bit of the user-defined information block crosses the destination user/system interface. The measurement of block transfer time is stopped when this event occurs.

Disengagement Request

A Disengagement Request occurs when either the originating or destination user signals his/her earth station to disconnect the call. The earth station then formats and transmits a circuit disconnect message via the inbound order wire to the MCS. The earth station originating the disconnect request waits for confirmation from the MCS before taking any further action. If confirmation does not arrive before a time out expires, the earth station retransmits the circuit disconnect message. The first Disengagement Request issued signifies the start of the disengagement time measurement.

Disengagement Confirmation

Upon reception of a circuit disconnect message, the MCS determines the validity of the request by checking its list of active circuits for the one identified in the disconnect message. If the circuit is on the list, the MCS sends a disconnect acknowledgment message via the outbound order wire to both earth stations using the circuit. If the circuit is not on the list, the circuit disconnect message is discarded. The Disengagement Confirmation allows both users to place other calls. The measurement of disengagement time is stopped when the user making the original disengagement request is able to place other calls.

4.3.3 Typical ACTS LBR Session

The above reference events are extremely useful for developing call session profiles. With these session profiles and details about the specific user/system interfaces, the relevant interface events needed for the data extraction step of the measurement process can be identified.

A system level session profile for a typical ACTS LBR call is illustrated in Figure 10, with the applicable primary and ancillary reference events identified. (see ANSI [1987] for a discussion on ancillary reference events.) In this session, the originating user initiates the call, transfers data, and then disengages the call. No user data or acknowledgments are transferred from the destination user back to the originating user. Figure 12 illustrates in greater detail the ACTS LBR system actions during a successful access request.

The session begins with the originating user going "off hook," thus issuing an Access Request (primary reference event 1) as the interface event. The originating user receives a "dial tone" from the local ACTS CO, indicating that he/she may enter the destination user's address. The system processes the request, signaling the destination user. The originating user receives a "ring-back" indicating that the destination user is being signaled. There are no primary reference events associated with this system event at the originating user's interface.

The destination user commits to the session by answering the call (going "off hook"), thus initiating reference event 2 as the interface event. The originating user receives the indication that the destination user is willing to communicate. Again there is no primary reference event associated with this interface event.

The originating user starts the communication session, thus initiating reference events 5 and 6. There is no primary reference event defined for the interface event of the destination user receiving the data.

The communication session continues in this fashion until the last bit of user information has been transferred across the origination user/system interface. As shown in Figure 10 and in greater detail in Figure 13, after the last bit of user information has entered the system, the originating user issues a disconnect request (primary reference event 8), to its local interface (user goes "on hook"). When the destination user receives this last bit of the

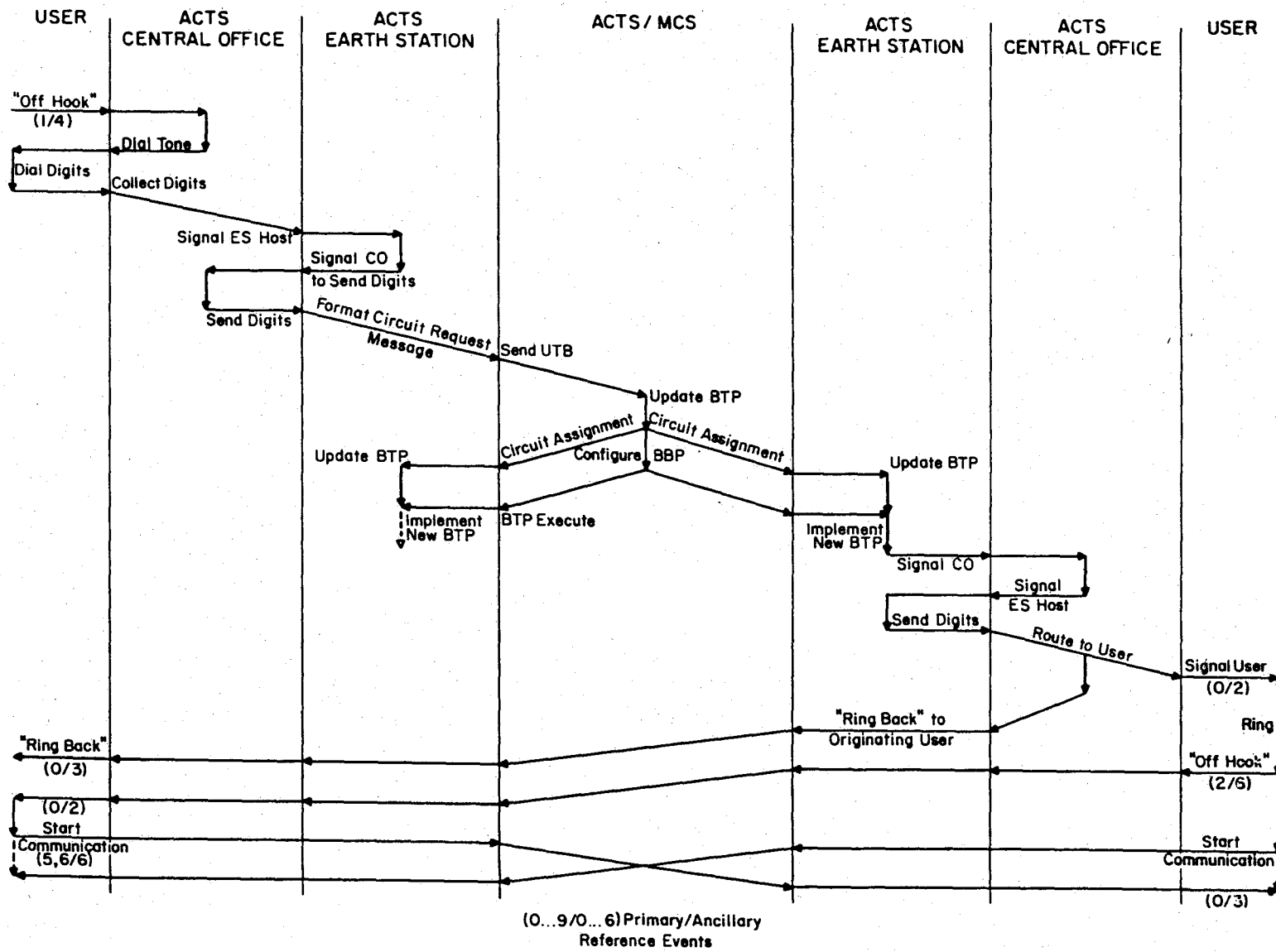
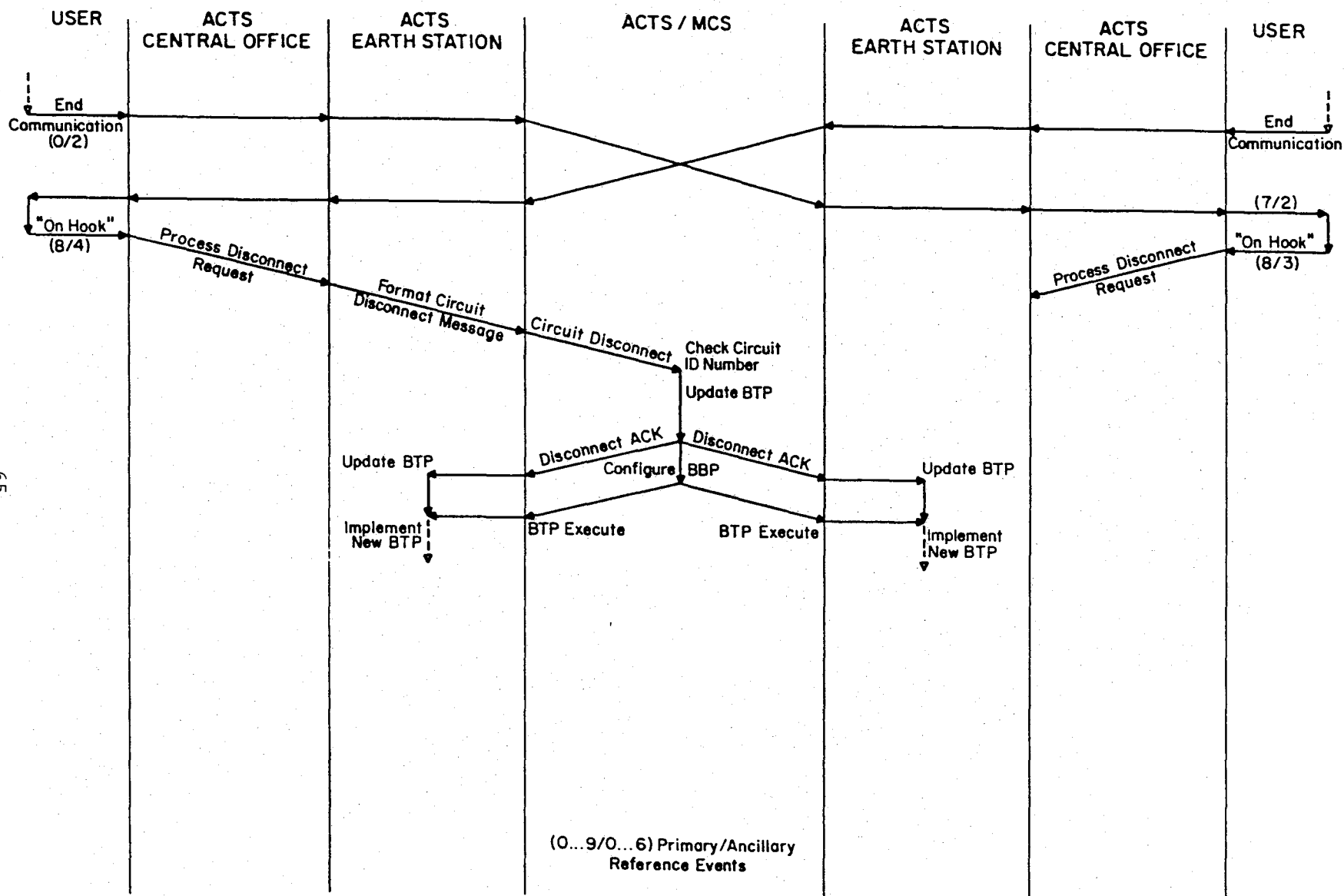

Figure 12. Session profile (successful access).



65

Figure 13. Session profile (successful disengagement).

user data, reference event 7 has occurred. The destination user then issues a disconnect request to its local interface.

Finally, after processing the disconnect requests, the MCS issues a disconnect acknowledgment (primary reference event 9) to both user's earth stations. If there is a need to accommodate additional circuit requests, the MCS will develop and distribute a new BTP. At this time the system is available for another call.

Session profiles similar to Figures 10, 12, and 13 can be drawn for the ACTS LBR system high-volume trunk and broadcast modes. The main difference is the need for multiple access and disconnect requests to establish the extra circuits.

Access requests can be blocked at several locations in the ACTS LBR system, thus contributing to the Access Denial Probability and Access Outage Probability discussed in Section 4.2.1. A cause of access blocking is shown in Figure 14 where the MCS ignores the circuit request. This would be due to the system operating close to or at capacity or the circuit request message was received in error and thus ignored. In this case the originating user will eventually go back "on hook," abandoning the call attempt if the connection is not made. Another form of access blocking occurs when the destination earth station cannot process the call request. This would be due to equipment problems with its local CO or lack of available CO trunks. As shown in Figure 15, when the destination earth station is blocking the call, it sends a circuit disconnect message to the MCS. No indication of blocking is sent to the originating user, however, and they will eventually go back "on hook," abandoning the call attempt.

One final form of access blocking occurs when the destination user is busy. As shown in Figure 16, the destination ACTS CO notes that the destination user is busy and sends a "busy tone" back to the originating user indicating user blocking (primary reference event 4). The originating user goes back "on hook," initiating a normal circuit disconnect sequence.

4.3.4 ACTS LBR System Performance Experiment Configuration

Figure 17 shows the ACTS LBR system configuration for system performance measurement experiments between a single user pair. During the experiments both users have 80286-class PCs running special experiment control and data

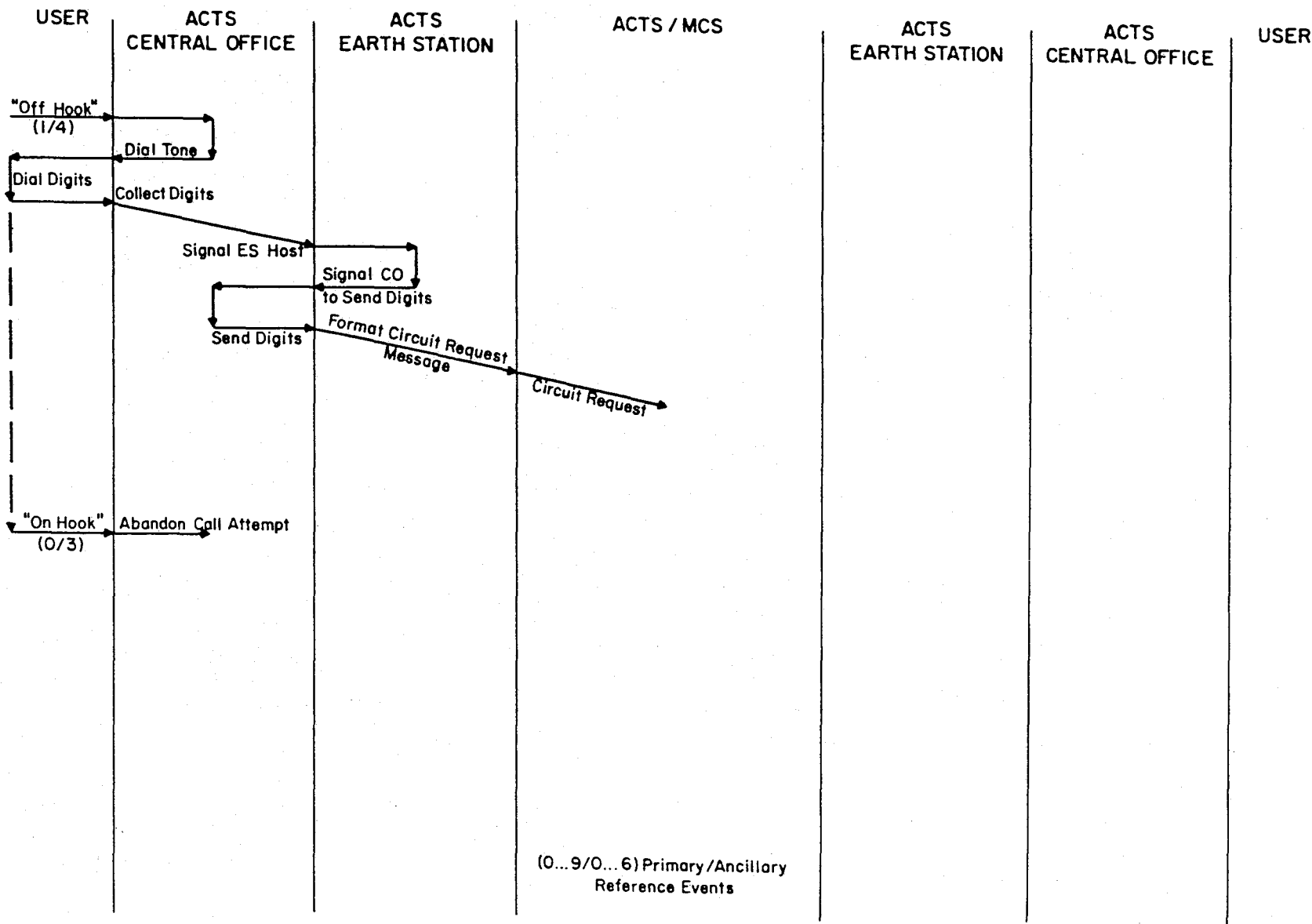

Figure 14. Unsuccessful access, blocked by MCS.

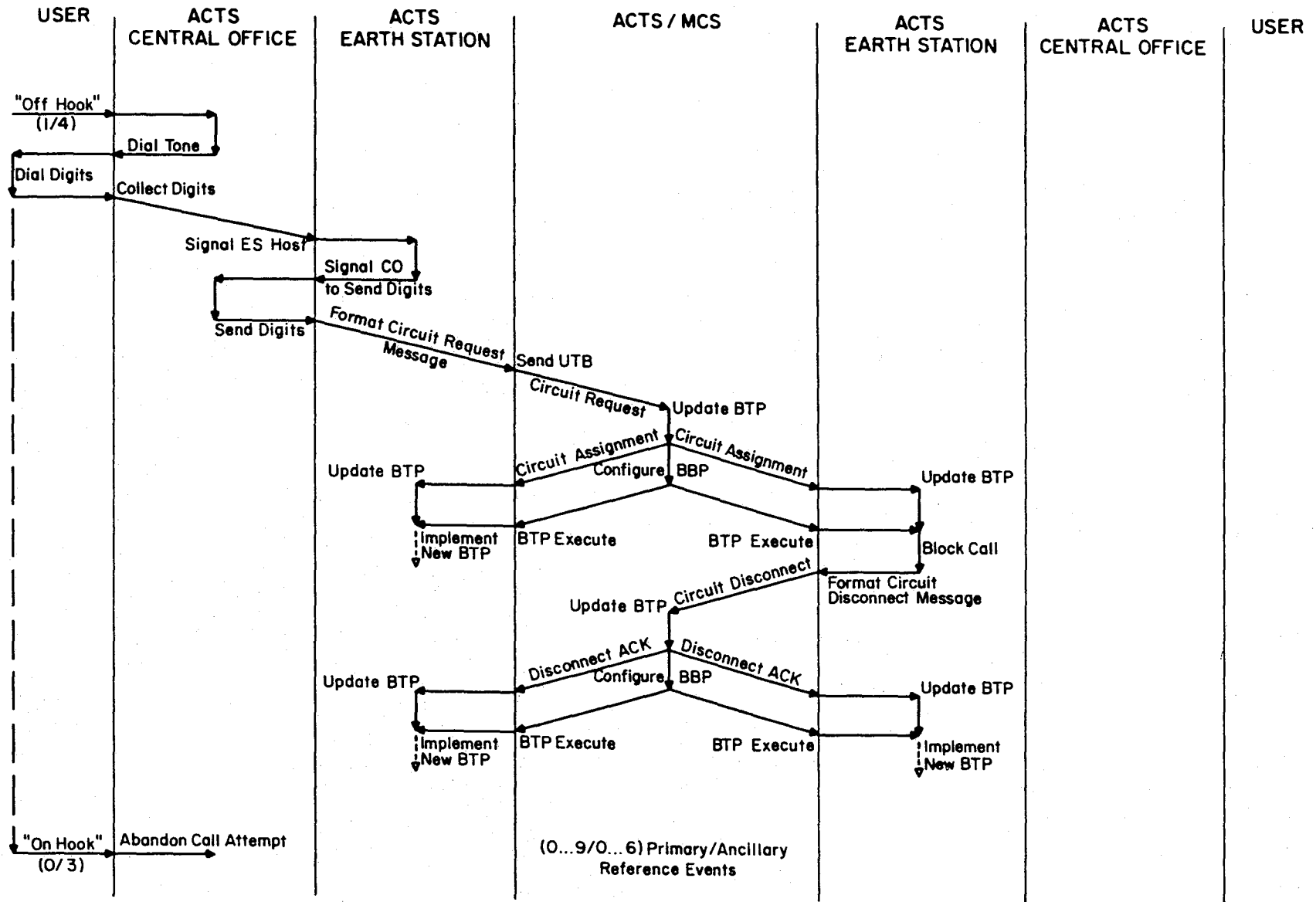

Figure 15. Unsuccessful access, blocked by destination earth station.

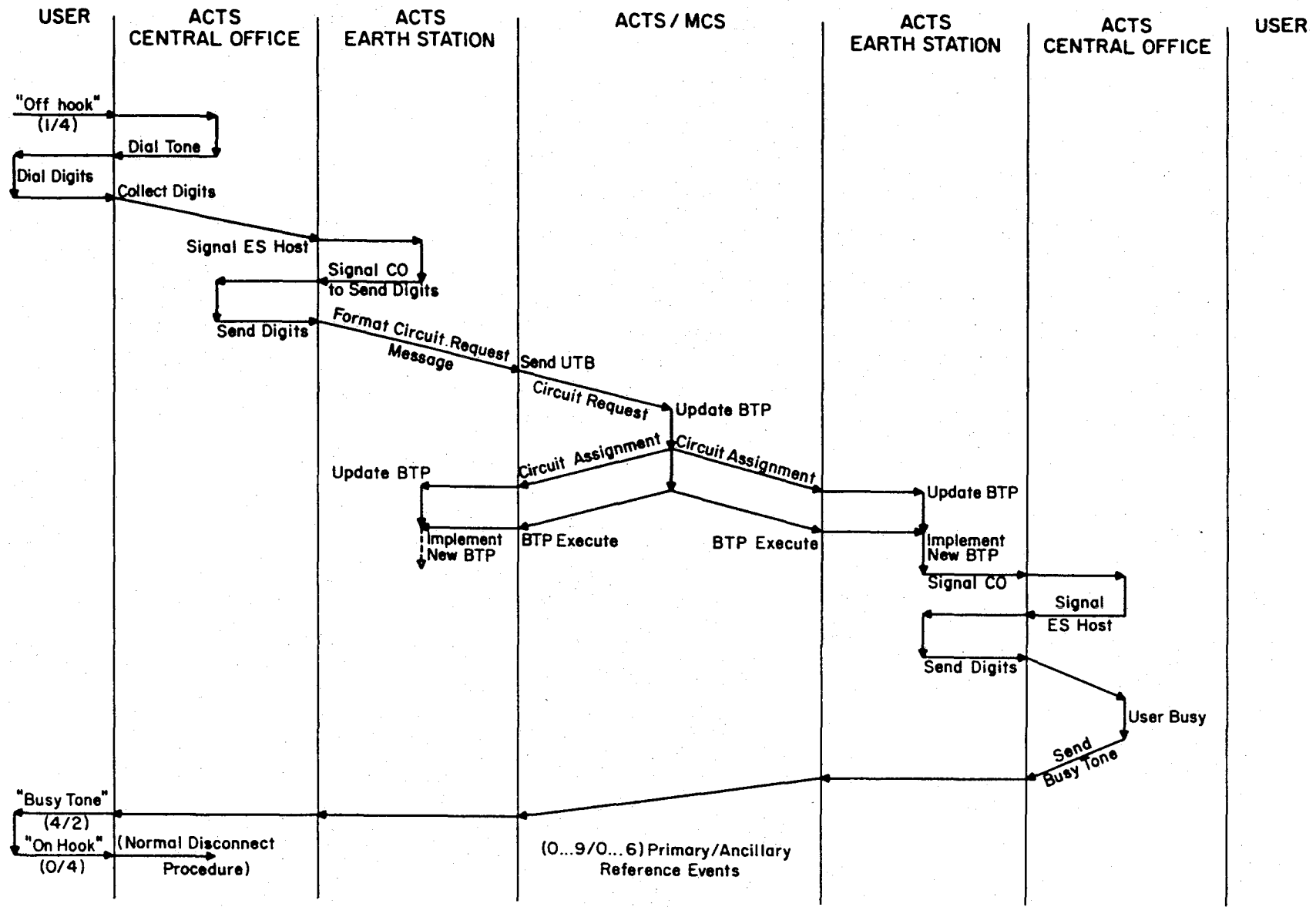

Figure 16. Unsuccessful access blocked by destination user.

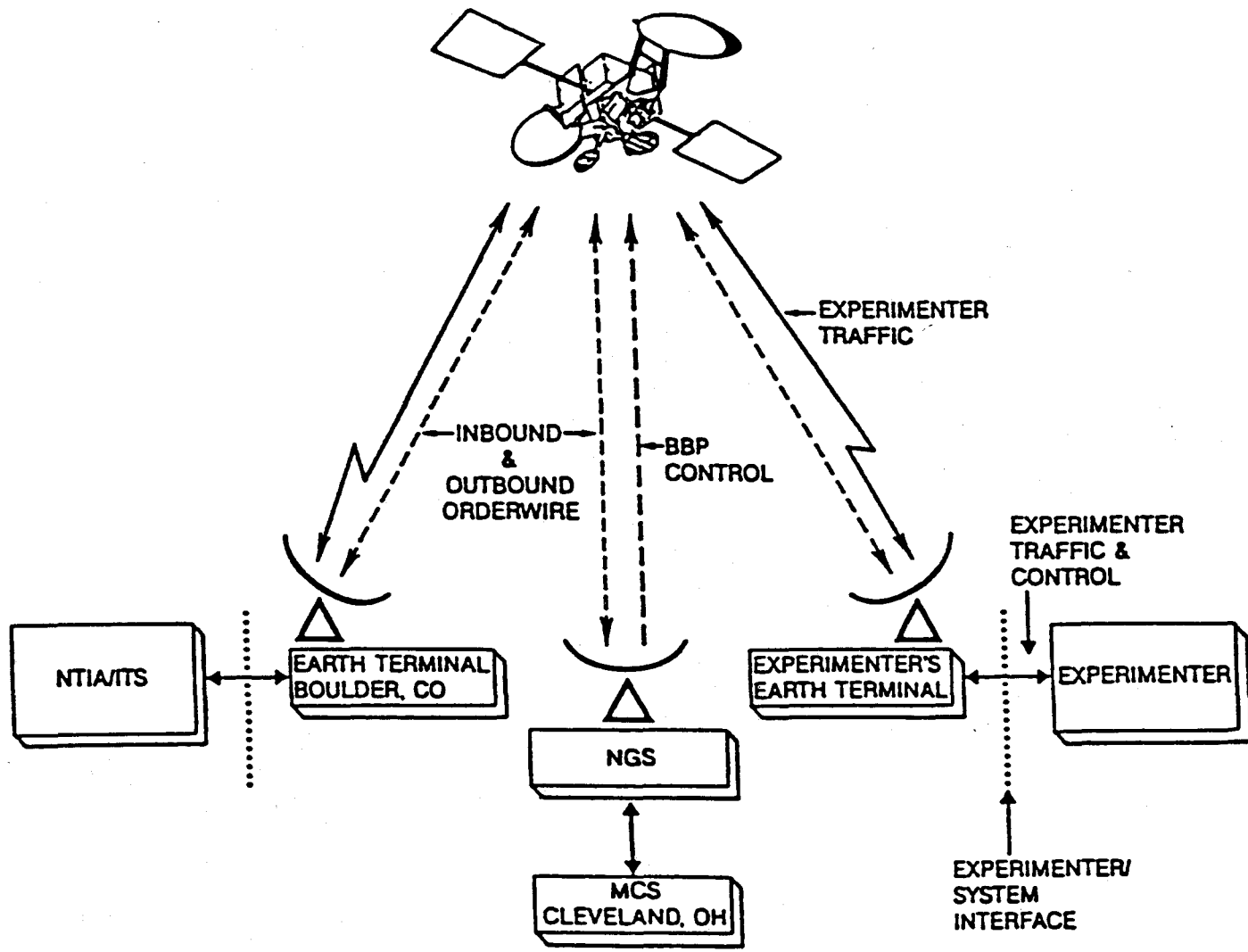

Figure 17. ACTS LBR communication system.

collection programs. The originating user's computer automatically calls the destination user's computer, transfers a preset number of pseudorandom datafiles, and then disconnects the call. Both user/system interfaces are monitored. At each step of the access, transfer, and disengagement functions, the relevant interface events are recorded and time stamped. Files of these time stamped reference events along with copies of the transferred data files are stored in both user's computers. In the data reduction step of the measurement process, estimates of the "speed" parameters are generated from the time-stamped reference event files and estimates of the "accuracy" and "reliability" parameters are generated by comparing the source and destination copies of the pseudorandom data files.

5. CONCLUSION

It has been established that the ANSI system performance standards can be used to measure and compare the performance of vastly different communication systems, most notably communication satellite systems. Using this "common yardstick" has many advantages: identifying what a particular system does best; helping to identify areas within a system that can be changed to improve performance, or pinpointing areas where costs can be reduced without serious impact on system performance; determining which competing system best fits a user's needs; identifying the deficient vendor in multivendor systems; and having the methods and tools to conduct repeatable system performance experiments.

By using these system performance standards for quantifying existing communication satellite system performance, the satellite service providers can market their product against terrestrial long-haul systems to relatively uneducated users. Users can easily evaluate how well these satellite systems compare with other transmission systems, how well these satellite systems meet their requirements, and how various configurations or factors affect the performance of these satellite systems.

By using these system performance standards for quantifying ACTS communication system performance, the improvements brought about by the advanced technology can be assessed and areas of improvement can be identified for use in future advanced communication satellite systems. Additionally,

efficient control protocols can be designed and evaluated for new generations of switched satellite systems.

Finally, as communication satellites like ACTS become even more advanced and the TDM switching becomes more sophisticated, one can envision the satellite as the central hub of a large, broadband ISDN. These satellite-augmented ISDN's could be part of a long-haul carrier's system, supplement a regional carrier's remote service area access, interconnect mobile communication services directly with local or long-haul communication systems, or accommodate "software bundled" private ISDNs for many geographically dispersed companies or institutions. In trying to market any of these diverse services, demonstrating and specifying the system performance in terms of the standards discussed here becomes critical.

6. ACKNOWLEDGMENTS

The author thanks Thomas Cony and Ronald Schertler of National Aeronautics and Space Administration (NASA) for their explanations and information on the ACTS LBR system. I also thank Neal Seitz of the Institute for Telecommunication Sciences (ITS) and William Kissick of the National Bureau of Standards (NBS) for their help in interpreting ANS X3.102 and ANS X3.141; Lenora Cahoon, Robert Kubichek, and Martin Nesenbergs of ITS for their review and comments; and Karen Henderson for her assistance in manuscript preparation.

7. REFERENCES

- ANSI (1983), American National Standard for information systems-data communication systems and services--user-oriented performance parameters, X3.102-1983, (American National Standards Institute, New York, NY).
- ANSI (1987), American National Standard for information systems-data communication systems and services--measurement methods for user-oriented performance evaluation, X3.141-1987, (American National Standards Institute, New York, NY).
- Byrne, T. (1985), Satellite vs. fiber: the competition heats up, *Lightwave* 2, No. 5, May, p. 27.
- Campanella, S.J., B.A. Pontano, and J.L. Dicks (1986), Advantages of TDMA and Satellite-Switched TDMA in INTELSAT V and VI, *COMSAT Tech. Rev.* 16, No. 1, Spring.
- Feher, K. (1983), *Digital Communications Satellite/Earth Station Engineering*, (Prentice-Hall Inc., Englewood Cliffs, NJ).
- Glen, D.V., E.C. Bolton, J.C. Blair, and P.M. McManamon (1976), Circuit status for multiple-satellite-hop user reaction tests, OT Special Publication 76-8, January, (NTIS Order No. PB 251561/AS).
- Gonze, J. (1987), Energy firms pick Nova-Net VSAT net, *Network World* 4, No. 48, November 30, p. 17.
- Inukai, T., D. Jupin, R. Lindstrom, and D. Meadows (1988), ACTS TDMA Network Control Architecture, Proc. AIAA 12th Int. Commun. Satellite Systems Conf., March.
- Lovell, R.R., and C.L. Guccia (1984), Type C communications satellites being developed for the future, *Microwave Sys. News* 14, No. 3, March.
- Miles, M.J. (1984), Sample size and precision in communication performance measurements, NTIA Report 84-153, August, (NTIS Order No. PB 85-114270).
- Moy, L.L. (1986), Advanced communication technology satellite, *Space Mag.* January.
- Naderi, F.M., and S.J. Campanella (1988), NASA's Advanced Communications Technology Satellite (ACTS): An Overview of the Satellite, the Network, and the Underlying Technology, Proc. AIAA 12th Int. Commun. Satellite Systems Conf., March.
- Potts, J. (1987), Satellites and ISDN, *Telecommunications*, October.
- Pritchard, W.L., and J.A. Sciulli (1986), *Satellite Communication Systems Engineering*, (Prentice-Hall Inc., Englewood Cliffs, NJ).
- Seitz, N.B., and D.S. Grubb (1983), American National Standard X3.102 User Reference Manual, NTIA Report 83-125, October, (NTIS Order No. PB 84-155571).
- Trusty, P.A., C.A. King, and P.W. Roach (1986), Generation of burst time plans for the INTELSAT TDMA system, *COMSAT Tech. Rev.* 16, No. 1, Spring.
- Wright, D.L. (1986), ACTS System Description, Proc. NASA ACTS Experiments Meeting #2, October.

APPENDIX: LINK BUDGET CALCULATIONS

This appendix gives a brief overview of the basic communication satellite link budget calculation. It concludes with a sample link budget calculation using link parameters for the high burst rate (HBR) reference station of the NASA Advanced Communications Technology Satellite (ACTS) system.

Link power budgets can be constructed for any radio frequency (rf) transmission system. Like any budget (financial or transmission link), the assets (transmit power and antenna gain) are summed and the liabilities (propagation losses, system losses, and thermal noise) are subtracted giving a net worth (C/No). The general rf link power budget equation is (all quantities are in decibels [dB])

$$C/No = EIRP + G/T_s - L_{fs} - L_{msc} + BO - k \quad [1]$$

where

C/No is the carrier-to-noise density ratio in dBHz,

EIRP is the equivalent isotropically radiated power in dBW,

G/T_s is the receive station figure of merit, gain-to-system noise temperature ratio in dB/K,

L_{fs} is the free space loss in dB,

L_{msc} is miscellaneous propagation and system losses in dB,

BO is the required satellite transponder back-off in dB, and

k = -228.6 dB/K, is Boltzmann's constant.

This equation is used for both the up link and down link of the satellite system. Feher (1983) and Pritchard and Sciulli (1986) give detailed derivations of this equation along with many examples of its application.

In communication satellite link performance calculations, C/No is the result of the link power budget calculation and primary parameter used in capacity calculations. The numerator, C, is the received carrier power. The denominator, No, is the received noise power normalized to a 1 Hz bandwidth. In link design calculations, C/No is a specified requirement that the link design must meet. An equivalent expression is C/kT_e, (kT_e = No), where k is Boltzmann's constant (1.38 x 10⁻²³ J/K) and T_e is the equivalent noise

temperature of the system, measured in Kelvin (K). The concept of equivalent noise temperature is covered in detail in Pritchard and Sciulli (1986). Another common expression is C/N, the carrier-to-noise ratio, where N is the total noise power in a specified bandwidth B ($N = B \times N_0$).

The numeric expression for equivalent isotropically radiated power (EIRP) is the transmitter output power (P_t) multiplied by the transmit antenna mainbeam gain (G_t)

$$\text{EIRP} = P_t \times G_t \quad [2]$$

Very often, when parabolic antennas are used, the antenna diameter and operating frequency are given in place of G_t . From these, the antenna gain is calculated by

$$G_t = \eta(\pi d/\lambda)^2 \quad [3]$$

where

η = the antenna efficiency, typically 0.55,

d = the antenna diameter in meters, and

λ = the wavelength.

The receive station figure of merit (G/T_s) is the ratio of the receive antenna gain, G , to the system noise temperature, T_s . The receive antenna gain is calculated in the same way as the transmit antenna gain above. From Jennings (1982), the system noise temperature is calculated by

$$T_s = T_A/\ell + T_\ell + T_E \quad [4]$$

where

T_A = the antenna noise temperature, K,

ℓ = the resistive losses (numeric) between the antenna and the receiver (usually the LNA which is the first component of the receiver),

T_{ℓ} = the contribution to system noise temperature due to resistive losses,

$$\ell = (1 - 1/\ell)290K, \text{ and} \quad [5]$$

T_E = the equivalent noise temperature of the receiver, which includes the LNA.

The receive station figure of merit, being a widely used parameter, is available for the majority of receiver systems (earth station or satellite) studied. If it is not stated in the system specification, it can be calculated as shown in Jennings (1982).

The free space loss, L_{fs} , is the propagation loss due to "spreading loss" of the transmitted signal and written numerically as

$$L_{fs} = (4\pi R/\lambda)^2 \quad [6]$$

where

R = the distance from the earth station to the satellite in meters.

λ = the wavelength in meters.

Other losses in the rf link are accounted for in L_{msc} . These include waveguide, polarization, pointing losses, and rain fade margin. If these losses are not specified, a value of 3 to 5 dB for C-band applications is typically assumed. For higher frequency bands such as Ka, these losses become more significant and difficult to predict. For example, NASA allocates 17.8 dB for L_{msc} , (8 dB for rain loss), on the HBR reference station down link during anticipated maximum rain fade conditions.

Much work has been done in the development of statistical rain attenuation models. Most efforts are based on the probability of point-rain-rates exceeding a certain percentage of the year for a given rain climate region. A detailed application of these models can be found in Pritchard and Sciulli (1986) and Flock (1988).

Satellite transponder back-off, BO, is used to control the intermodulation distortion (noise) generated in the transponder output power amplifier (traveling wave tube amplifier [TWTA] or solid-state power amplifier [SSPA]).

Intermodulation distortion is generated when the amplifier is operated in the nonlinear portion of its transfer curve (the amplifier is saturated). To reduce this distortion, the power amplifier is "backed off," i.e., operated below saturation. Amplifier manufacturers supply transfer characteristic curves from which the required back-off for the system can be determined.

Intermodulation distortion is more prevalent in FM/FDM/FDMA systems with multiple carriers and contributes to the quantities known as AM-AM and AM-PM conversion and crosstalk. Jennings (1982) and Pritchard and Sciulli (1986) discuss the impact on the overall system C/No of intermodulation distortion caused by multiple carriers within a single transponder and intermodulation between adjacent transponders. However, when the transponder is sufficiently "backed off," these effects are usually small and can be absorbed in the miscellaneous losses entry.

Problems with intermodulation distortion highlight the advantages of digital modulation and TDMA systems. With most digital modulation techniques, the signal has a constant envelope, thus reducing the AM-AM and AM-PM conversion and intermodulation products. With TDMA systems there is only one carrier present at a time, thus intermodulation distortion is even further reduced. This allows the transponder to be operated closer to saturation, thus increasing the down link EIRP. However, there is still the potential for intermodulation distortion due to adjacent transponders.

There are two ways to implement back-off: Input back-off (BO_i), where the power flux density at the satellite receive antenna is reduced, and output back-off (BO_o), where the satellite power amplifier gain is reduced. When using input back-off, the receive power flux density required to operate the satellite transponder power amplifier at saturation is defined as ψ , the saturated power flux density, and given (expressed as dBW/m²) by

$$\psi = EIRP_{up} - L_{fsup} - L_{mscup} + 4\pi/\lambda^2 + BO_i \quad [7]$$

The maximum saturated power flux density is typically specified by the satellite carrier. Equation [7] is then used to calculate the required up link EIRP. When using output back-off attenuation is inserted in the transponder to reduce the power amplifier gain by the desired output back-off BO_o .

The current generation of communication satellites favors output back-off. This allows a higher EIRP on the up link and thus a higher $C/N_{o_{up}}$. Satellite carriers such as INTELSAT set limits on the maximum allowable power flux density to -84.0 dBW/m² for multicarrier operation with global coverage antennas (Jennings, 1982). The disadvantage of output back-off is that it requires extra satellite hardware and control links for adjusting the transponder gain.

Overall link performance is a combination of up link, down link, and intermodulation carrier-to-noise density ratios. Mathematically it is expressed as

$$C/N_{o_T}^{-1} = C/N_{o_{up}}^{-1} + C/N_{o_{dn}}^{-1} + C/N_{o_i}^{-1} \quad [8]$$

where C/N_{o_i} is due to the intermodulation products generated in the satellite transponder power amplifier. (Note: this expression uses the numeric, not the decibel, values of these quantities.) With the total link carrier-to-noise density ratio, system capacity can be calculated.

Analog transmission system capacity is based on the required (specified according to application) baseband signal-to-noise ratio (S_b/N_b). For amplitude modulated (AM) systems, the baseband signal-to-noise ratio and received carrier-to-noise density ratio are related by

$$S_b/N_b = C/No \times 1/B, \quad [9]$$

where

$$\begin{aligned} B &= \text{the modulated signal bandwidth and} \\ &= 2 \times f_m \text{ (twice the highest baseband frequency, } f_m \text{).} \end{aligned}$$

For frequency modulated (FM) systems, the baseband signal-to-noise ratio and received carrier-to-noise density ratio (for single channel per carrier [SCPC] systems) are related by

$$S_b/N_b = 3m^2 \times 1/2f_m \times C/No \quad [10]$$

where

f_m = the highest baseband frequency,

m = the modulation index and

$$= \Delta f / f_m$$

Δf = the peak frequency deviation.

An approximate FM baseband bandwidth is found from Carson's rule

$$B = 2f_m(m + 1). \quad [11]$$

From these bandwidths and maximum frequencies, system channel capacity can be calculated. Pritchard and Sciulli (1986) do this for various channel multiplex hierarchies. They also expand these basic equations to cover multiple channel per carrier and television applications, including preemphasis and psophometric weighing factors typically specified FM multiplex systems.

System capacity calculations for digital transmission systems are somewhat simplified. The basic unit of measure is the bit energy-to-noise density ratio (E_b/N_o). For BPSK E_b/N_o is directly related to C/N_o by

$$E_b/N_o = C/N_o \times T_b \quad [12]$$

where

T_b = the transmitted bit duration in seconds and

$$= 1/R_b \text{ (the inverse of the transmitted bit rate).}$$

For power limited satellite communication systems, Figure A-1 shows the theoretical relationship between bit error probability and E_b/N_o . In practical systems this relationship also depends on the modulation techniques and error correction coding used. Feher (1983) and Whalen (1971) discuss at length, the relationships of P_e , E_b/N_o , modulation, and coding.

With the required P_e , and knowledge of the modulation techniques and error correction coding used, the required E_b/N_o can be found from graphs like Figure A-1. From this, and the satellite link C/N_o , the channel transmitted bit rate can be found by

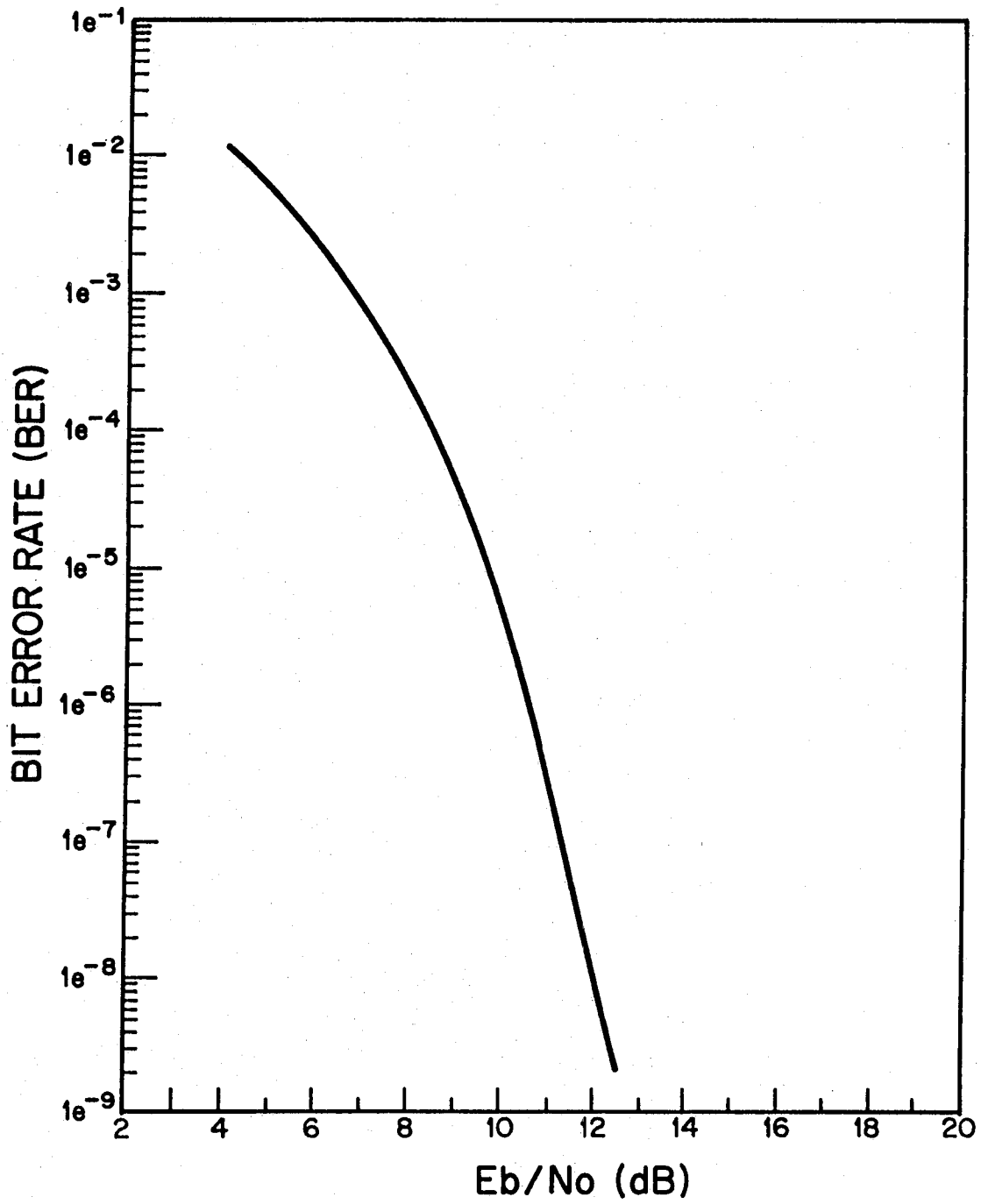

Figure A-1. Bit error rate vs. E_b/N_0 .

$$R_b = (C/N_o)/(E_b/N_o). \quad [13]$$

The user's data rate is related to the transmitted bit rate by the modulation technique and error correction coding used. In TDMA systems, the user's data rate also depends on the length of the TDMA frame and number of overhead bits in the various control and synchronization fields. Feher (1983) and Pritchard and Sciulli (1986) discuss TDMA frame structures, synchronization techniques, and system capacity calculations.

Using the relationship of E_b/N_o and P_e from Figure A-1, the advantage of onboard digital signal regeneration is easily shown. For example

$$\text{let } E_b/N_{o_{up}} = 10.5 \text{ dB, and}$$

$$E_b/N_{o_{dn}} = 10.5 \text{ dB,}$$

from Figure A-1,

$$P_{e_{up}} = P_{e_{dn}} = 1 \times 10^{-6}.$$

For systems with onboard digital regeneration the total probability of error is the sum of the error probabilities for each link. Therefore,

$$\begin{aligned} P_{e_{total}} &= P_{e_{up}} + P_{e_{dn}} & [14] \\ &= (1 \times 10^{-6}) + (1 \times 10^{-6}) \\ &= 2 \times 10^{-6}. \end{aligned}$$

For systems without regeneration the total system E_b/N_o is first be calculated (using numeric values)

$$\begin{aligned} (E_b/N_o)_T^{-1} &= (E_b/N_o)_{up}^{-1} + (E_b/N_o)_{dn}^{-1} & [15] \\ &= (11.22)_{up}^{-1} + (11.22)_{dn}^{-1}. \end{aligned}$$

Therefore, the total system $E_b/N_o = 5.61$, yielding,

$$(E_b/N_o)_T = 7.5 \text{ dB,}$$

from Figure A-1,

$$P_{e_{total}} = 7 \times 10^{-3}.$$

Thus, with onboard regeneration, a significant improvement in error performance is achieved. Another way to look at this is, for a given P_e , the required transmit power can be reduced when using onboard digital signal regeneration.

The following example demonstrates link power budget calculations for the NASA ACTS HBR system operating as a SS/TDMA communication satellite. The following parameters apply to the NASA ACTS HBR reference station in Cleveland, Ohio.

Up link frequency: 29.68 GHz
Down link frequency: 19.96 GHz
Earth station transmitter power: 14.0 dBW
Satellite transmitter power: 9.0 dBW
Earth station antenna diameter: 4.7 m
Satellite receive antenna diameter: 2.2 m
Satellite transmit antenna diameter: 3.3 m
Earth station antenna efficiency: 0.60
Earth station antenna temperature: 150 K
Satellite receive antenna temperature: 150 K
Up link receive system losses: 0.80 dB
Down link receive system losses: 1.60 dB
Up link receiver equivalent noise temperature: 715.5 K
Down link receiver equivalent noise temperature: 2354.8 K
Path length (for Cleveland): 37,851.6 km
Up link Polarizer loss: 1.2 dB
Up link receive loss: 1.8 dB
Down link receive loss: 0.5 dB
Up link pointing loss: 0.5 dB
Down link pointing loss: 0.5 dB
Up link transmit feed loss: 3.0 dB
Down link transmit feed loss: 2.6 dB
Up link atmospheric loss: 0.8 dB
Down link atmospheric loss: 0.6 dB
Down link transmit antenna loss: 4.0 dB
Up link data rate (burst): 220 Mb/s
Down link data rate (burst): 220 Mb/s
Down link modem implementation loss: 3.0 dB

The up link EIRP:

$$EIRP_{up} = P_t \times G_t$$

where

$$P_t = 14.0 \text{ dBW (25.12 watts), transmit power}$$

$$G_t = \eta(\pi d/\lambda)^2, \text{ transmit antenna gain}$$

$$\eta = 0.6 \text{ (given), transmit antenna efficiency}$$

$$d = 4.7 \text{ m (given), transmit antenna diameter}$$

$$\lambda = c/f$$

$$c = 2.99 \times 10^8 \text{ m/s (assumed)}$$

$$f = 29.68 \times 10^9 \text{ Hz (given), up link frequency}$$

$$\text{Therefore, } \lambda = 2.99 \times 10^8 \text{ ms} / 29.68 \times 10^9 \text{ Hz} = 10.074 \times 10^{-3} \text{ m.}$$

$$\begin{aligned} \text{Therefore, } G_t &= 0.6 (\pi(4.7)/10.074 \times 10^{-3})^2 \\ &= 1.289 \times 10^6 \text{ (61.1 dB)} \end{aligned}$$

Therefore,

$$\begin{aligned} \text{EIRP}_{\text{up}} &= (25.12)(1.289 \times 10^6) \\ &= 32.380 \times 10^6 \text{ (75.1 dBW)} \end{aligned}$$

The up link G/Ts:

$$\begin{aligned} G_R &= \eta(\pi d/\lambda)^2, \text{ receive antenna gain} \\ \eta &= 0.55 \text{ (assumed), receive antenna efficiency} \\ d &= 2.2 \text{ m (given), receive antenna diameter} \\ \lambda &= 10.074 \times 10^{-3} \text{ m (from EIRP}_{\text{up}} \text{ calculation)} \end{aligned}$$

$$\begin{aligned} \text{Therefore, } G_R &= 0.55 (\pi(2.2)/10.074 \times 10^{-3})^2 \\ &= 258.880 \times 10^3 \text{ (54.1 dB)} \end{aligned}$$

Receive antenna loss:	Polarizer loss	1.2 dB
	Receive loss	1.8 dB
	Pointing loss	<u>0.5 dB</u>
	Loss =	3.5 dB

$$\begin{aligned} \text{Therefore, } G &= G_R - \text{Loss} \\ &= 54.1 \text{ dB} - 3.5 \text{ dB} \\ &= 50.6 \text{ dB (115.640} \times 10^3) \end{aligned}$$

$$T_s = T_A/\ell + T_\ell + T_E, \text{ system temperature}$$

$$T_A = 150 \text{ K (given), antenna temperature}$$

$$\ell = 0.8 \text{ dB (given), receive system losses}$$

converting to numeric values; $\ell = 1.2$

$$\begin{aligned}
T_{\ell} &= (1 - 1/\ell) \times 290, \text{ equivalent loss temperature} \\
&= (1 - 1/1.2) \times 290 \\
&= 48.3 \text{ K.}
\end{aligned}$$

$$T_E = 715.5 \text{ K (given), receiver equivalent noise temperature}$$

$$\begin{aligned}
\text{Therefore, } T_s &= 150/1.2 + 48.3 + 715.5 \\
&= 888.8 \text{ K.}
\end{aligned}$$

$$\text{Therefore, } G/T_s = 115.64 \times 888.8 \times 10^3 = 130.11 \text{ (21.1 dB/K).}$$

The up link free space loss, L_{fs} :

$$\begin{aligned}
L_{fs} &= (4 \pi R/\lambda)^2 \\
R &= 37,851.6 \text{ Km (given for Cleveland)} \\
\lambda &= 10.074 \times 10^{-3} \text{ m (from EIRP}_{up} \text{ calculation)} \\
L_{fs} &= (4\pi(37,851.6 \times 10^3)/10.074 \times 10^{-3})^2 \\
&= 2.2294 \times 10^{21} \text{ (213.5 dB).}
\end{aligned}$$

Up link miscellaneous loss, L_{msc} :

$$\begin{aligned}
\text{Transmit feed loss} &= 3.0 \text{ dB} \\
\text{Pointing loss} &= 0.5 \text{ dB} \\
\text{Atmospheric loss} &= \underline{0.8 \text{ dB}} \\
L_{msc} &= 4.3 \text{ dB}
\end{aligned}$$

The up link power flux density at Satellite, Φ :

$$\begin{aligned}
\Phi &= \text{EIRP}_{up} - L_{fs} - L_{msc} + (4\pi/\lambda^2)_{dB} \\
4\pi/\lambda^2 &= 4\pi/(10.074 \times 10^{-3})^2 \\
&= 123.82 \times 10^3 \text{ (50.9 dB/m}^2\text{)}.
\end{aligned}$$

$$\begin{aligned}
\text{Therefore, } \Phi &= 75.1 \text{ dBW} - 213.5 \text{ dB} - 4.3 \text{ dB} + 50.9 \text{ dB/m}^2 \\
&= -91.8 \text{ dBW/m}^2.
\end{aligned}$$

Since this HBR mode operates as a TDMA system, "back-off" is not needed.

$$BO_i = BO_0 = 0 \text{ dB.}$$

Therefore, the Link power budget for the up link is

$$\begin{aligned}C/N_o &= \text{EIRP}_{\text{up}} + G/T_s - L_{fs} - L_{\text{msc}} + K_{\text{dB}} \\ &= 75.1 \text{ dBW} + 21.1 \text{ dB/K} - 213.5 \text{ dB} - 4.3 \text{ dB} + 228.6 \text{ dB/K} \\ &= 107 \text{ dB Hz} (50.12 \times 10^9).\end{aligned}$$

The up link E_b/N_o :

$$\begin{aligned}E_b/N_o &= C/N_o \times T_b \\ T_b &= 1/R_b = 1/220 \times 10^6, \text{ transmit bit duration}\end{aligned}$$

$$\begin{aligned}E_b/N_o &= 50.12 \times 10^9 / 220 \times 10^6 \\ &= 227.81 (23.6 \text{ dB}).\end{aligned}$$

The down link EIRP:

$$\text{EIRP}_{\text{dn}} = P_T \times G_T$$

where $P_T = 9 \text{ dBW}$ (7.9 watts), transmit power

$$G_T = \eta (\pi d/\lambda)^2, \text{ transmit antenna gain}$$

$\eta = 0.55$ (assumed), transmit antenna efficiency

$d = 3.3 \text{ m}$ (given), transmit antenna diameter

$$\lambda = c/f$$

$$c = 2.99 \times 10^8 \text{ m/s (assumed)}$$

$f = 19.96 \times 10^9 \text{ Hz}$ (given) down link frequency

$$\lambda = (2.99 \times 10^8) / (19.96 \times 10^9) = 14.980 \times 10^{-3} \text{ m}$$

$$\begin{aligned}G_T &= 0.55 (\pi(3.3)/14.980 \times 10^{-3})^2 \\ &= 263.43 \times 10^3 (54.2 \text{ dB}).\end{aligned}$$

$$\begin{aligned}\text{Therefore, } \text{EIRP}_{\text{dn}} &= (7.9)(263.43 \times 10^3) \\ &= 2.0811 \times 10^6 (63.2 \text{ dBW}).\end{aligned}$$

The down link G/T_s :

$$G_R = \eta(\pi d/\lambda)^2, \text{ receive antenna gain}$$

$$\eta = 0.6 \text{ (given), receive antenna efficiency}$$

$$d = 4.7 \text{ m (given), receive antenna diameter}$$

$$\lambda = 14.980 \times 10^{-3} \text{ m (from EIRP}_{dn} \text{ calculation)}$$

$$\begin{aligned} G_R &= 0.6 (\pi(4.7)/14.980 \times 10^{-3})^2 \\ &= 582.94 \times 10^3 \text{ (57.7 dB)} \end{aligned}$$

Receive antenna loss: Pointing loss 0.5 dB.

Therefore,

$$G = G_R - \text{Loss}$$

$$= 57.7 - 0.5$$

$$= 57.2 \text{ dB (519.54} \times 10^3)$$

$$T_s = T_A/\ell + T_\ell + T_E, \text{ system temperature}$$

$$T_A = 150 \text{ K (given), antenna temperature}$$

$$\ell = 1.6 \text{ dB (1.45), receive system losses}$$

$$T_\ell = (1 - 1/\ell) \times 290, \text{ equivalent loss temperature}$$

$$= (1 - 1/1.45) \times 290$$

$$= 89.4 \text{ K}$$

$$T_E = 2354.8 \text{ K (given), receiver equivalent noise temperature.}$$

Therefore,

$$T_s = 150/1.45 + 89.4 + 2354.8$$

$$= 2,547.6 \text{ K}$$

Therefore,

$$G/T_s = 519.54 \times 10^3 / 2,547.6$$

$$= 203.93 \text{ (23.1 dB/K).}$$

The down link free space loss, L_{fs} :

$$L_{fs} = (4\pi R/\lambda)^2$$

$R = 37,851.6 \text{ km}$ (given for Cleveland)

$\lambda = 14.980 \times 10^{-3} \text{ m}$ (from EIRP_{dn} calculation)

$$\begin{aligned} L_{fs} &= (4\pi(37,851.6 \times 10^3)/14.98 \times 10^{-3})^2 \\ &= 1.0082 \times 10^{21} \text{ (210.0 dB)} \end{aligned}$$

Down link miscellaneous loss, L_{msc} :

Transmit loss = 2.6 dB

Antenna loss = 4.0 dB

Pointing loss = 0.5 dB

Atmospheric loss = 0.6 dB

$$L_{\text{msc}} = 7.7 \text{ dB}$$

Since no "back-off" is used, the down link power budget is:

$$\begin{aligned} C/\text{No} &= \text{EIRP}_{\text{dn}} + G/T_s - L_{fs} - L_{\text{msc}} + K_{\text{dB}} \\ &= 63.2 \text{ dBW} + 23.1 \text{ dBK} - 210.0 \text{ dB} - 7.7 \text{ dB} + 228.6 \text{ dBJ/K} \\ &= 97.2 \text{ dBW} (5.248 \times 10^9). \end{aligned}$$

The down link E_b/No :

$$E_b/\text{No} = C/\text{No} \times T_b$$

$$T_b = 1/R_b = 1/220 \times 10^6, \text{ transmit bit duration}$$

Therefore, $E_b/\text{No} = 5.248 \times 10^9 / 220 \times 10^6$

$$= 23.86 \text{ (13.8 dB)}.$$

The overall system C/No :

Note: In the HBR mode there is no signal regeneration.

Assume no intermodulation distortion since the system is operating in a TDMA mode.

Therefore,

$$(C/\text{No})_T^{-1} = (C/\text{No})_{\text{up}}^{-1} + (C/\text{No})_{\text{dn}}^{-1}$$

$$= 1/50.12 \times 10^9 + 1/5.248 \times 10^9$$

$$= 210.5 \times 10^{-12}$$

$$C/No_T = 4.75 \times 10^9 \text{ (96.8 dBW)}.$$

Therefore, the overall system Eb/No:

$$Eb/No_T = C/No_T \times T_b$$

$$= 4.75 \times 10^9 / 220 \times 10^9$$

$$= 21.59 \text{ (13.3 dB)}$$

REFERENCES

- Feher, K. (1983), Digital Communications Satellite/Earth Station Engineering, (Prentice-Hall Inc., Englewood Cliffs, NJ).
- Flock, W.L. (1988), Propagation Effects on Satellite Systems at Frequencies Below 10 GHz, a Handbook for Satellite Systems Design, second edition, NASA Reference Publication 1108 (2).
- Jennings, R.D. (1982), Parametric approach to thin-route earth-station requirements, NTIA Report 82-99, March, (NTIS Order No. PB 82-244559).
- Pritchard, W.L., and J.A. Sciulli (1986), Satellite Communication Systems Engineering, (Prentice-Hall Inc., Englewood Cliffs, NJ).
- Whalen, A.D. (1971), Detection of Signals in Noise, (Academic Press, Inc., Orlando, FL).

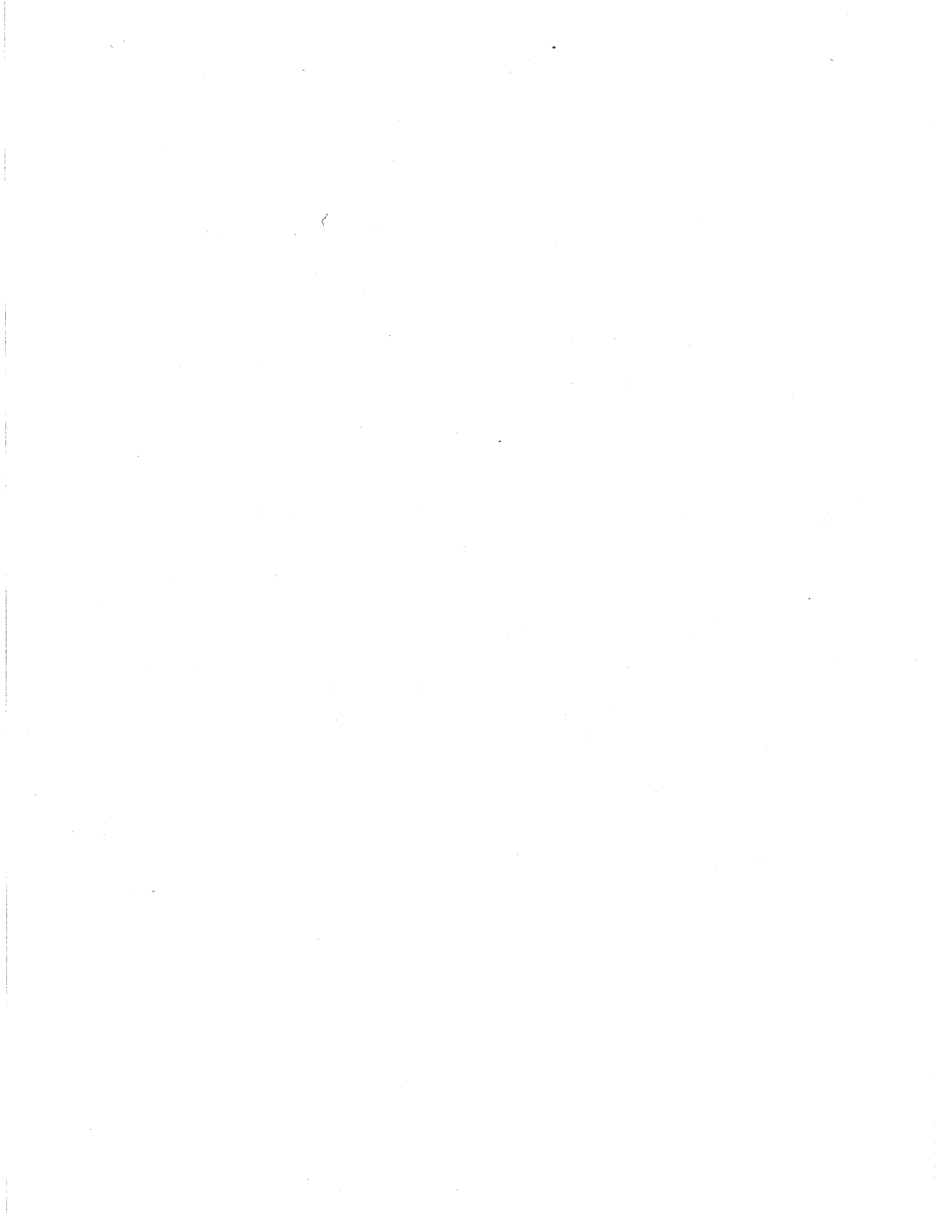

BIBLIOGRAPHIC DATA SHEET

1. PUBLICATION NO. NTIA Report 88-234		2. Gov't Accession No.	3. Recipient's Accession No.
4. TITLE AND SUBTITLE Suitability of ANSI Standards for Quantifying Communication Satellite System Performance		5. Publication Date August 1988	6. Performing Organization Code NTIA/ITS.N1
7. AUTHOR(S) Robert D. Cass		9. Project/Task/Work Unit No.	
8. PERFORMING ORGANIZATION NAME AND ADDRESS National Telecommunications and Information Admin. Institute for Telecommunication Sciences 325 Broadway Boulder, CO 80303		10. Contract/Grant No.	
11. Sponsoring Organization Name and Address NASA Lewis Research Center 21000 Brookpark Rd. Office Code 6100 Cleveland, OH 44135		12. Type of Report and Period Covered	
14. SUPPLEMENTARY NOTES		13.	
15. ABSTRACT (A 200-word or less factual summary of most significant information. If document includes a significant bibliography or literature survey, mention it here.) This report details a study on the application of American National Standards X3.102 and X3.141 to various classes of communication satellite systems from the simple analog "bent-pipe" to NASA's Advanced Communications Technology Satellite (ACTS). These standards are proposed as a means for quantifying the end-to-end communication system performance of communication satellite systems. An introductory overview of the two standards are given followed by a review of the characteristics, applications, and advantages of using X3.102 and X3.141 to quantify the performance these classes of communication satellites. The report concludes with a description of the application of these standards to ACTS.			
16. Key Words (Alphabetical order, separated by semicolons) ACTS; American National Standard; baseband switching; DAMA; digital communication; ISDN; system performance measurement; SS/TDMA; TDMA; users			
17. AVAILABILITY STATEMENT <input checked="" type="checkbox"/> UNLIMITED. <input type="checkbox"/> FOR OFFICIAL DISTRIBUTION.		18. Security Class. (This report) Unclassified	20. Number of pages 102
		19. Security Class. (This page) Unclassified	21. Price:



