



---

---

# National Institute of Justice

**Law Enforcement and Corrections Standards and Testing Program**

## **Antenna System Guide**

**NIJ Guide 202-00**

## ABOUT THE LAW ENFORCEMENT AND CORRECTIONS STANDARDS AND TESTING PROGRAM

The Law Enforcement and Corrections Standards and Testing Program is sponsored by the Office of Science and Technology of the National Institute of Justice (NIJ), U.S. Department of Justice. The program responds to the mandate of the Justice System Improvement Act of 1979, which directed NIJ to encourage research and development to improve the criminal justice system and to disseminate the results to Federal, State, and local agencies.

The Law Enforcement and Corrections Standards and Testing Program is an applied research effort that determines the technological needs of justice system agencies, sets minimum performance standards for specific devices, tests commercially available equipment against those standards, and disseminates the standards and the test results to criminal justice agencies nationally and internationally.

The program operates through:

The *Law Enforcement and Corrections Technology Advisory Council* (LECTAC), consisting of nationally recognized criminal justice practitioners from Federal, State, and local agencies, which assesses technological needs and sets priorities for research programs and items to be evaluated and tested.

The *Office of Law Enforcement Standards* (OLES) at the National Institute of Standards and Technology, which develops voluntary national performance standards for compliance testing to ensure that individual items of equipment are suitable for use by criminal justice agencies. The standards are based upon laboratory testing and evaluation of representative samples of each item of equipment to determine the key attributes, develop test methods, and establish minimum performance requirements for each essential attribute. In addition to the highly technical standards, OLES also produces technical reports and user guidelines that explain in nontechnical terms the capabilities of available equipment.

The *National Law Enforcement and Corrections Technology Center* (NLECTC), operated by a grantee, which supervises a national compliance testing program conducted by independent laboratories. The standards developed by OLES serve as performance benchmarks against which commercial equipment is measured. The facilities, personnel, and testing capabilities of the independent laboratories are evaluated by OLES prior to testing each item of equipment, and OLES helps the NLECTC staff review and analyze data. Test results are published in Equipment Performance Reports designed to help justice system procurement officials make informed purchasing decisions.

Publications are available at no charge from the National Law Enforcement and Corrections Technology Center. Some documents are also available online through the Internet/World Wide Web. To request a document or additional information, call 800-248-2742 or 301-519-5060, or write:

National Law Enforcement and Corrections Technology Center  
P.O. Box 1160  
Rockville, MD 20849-1160  
E-mail: [asknlectc@nlectc.org](mailto:asknlectc@nlectc.org)  
World Wide Web address: <http://www.nlectc.org>

The National Institute of Justice is a component of the Office of Justice Programs, which also includes the Bureau of Justice Assistance, the Bureau of Justice Statistics, the Office of Juvenile Justice and Delinquency Prevention, and the Office for Victims of Crime.

**U.S. Department of Justice**  
**Office of Justice Programs**  
*National Institute of Justice*

---

## **Antenna System Guide**

**NIJ Guide 202-00**

**W.A. Kissick, W.J. Ingram, J.M. Vanderau, R.D. Jennings**  
**Institute for Telecommunication Sciences**  
**Boulder, CO 80305-3328**

**Prepared for:**  
**National Institute of Justice**  
**Office of Science and Technology**  
**Washington, DC 20531**

**April 2001**

**NCJ 185030**

## **National Institute of Justice**

The technical effort to develop this guide was conducted  
under Interagency Agreement 94-IJ-R-004,  
Project No. 97-030-CTT.

This guide was prepared by the  
Office of Law Enforcement Standards (OLES)  
of the National Institute of Standards and Technology (NIST)  
under the direction of A. George Lieberman, Program  
Manager, Detection, Inspection, and Enforcement  
Technologies, and Kathleen M. Higgins, Director of OLES.  
The work resulting in this guide was sponsored by the  
National Institute of Justice, Dr. David G. Boyd,  
Director, Office of Science and Technology.

## FOREWORD

The Office of Law Enforcement Standards (OLES) of the National Institute of Standards and Technology furnishes technical support to the National Institute of Justice program to strengthen law enforcement and criminal justice in the United States. OLES's function is to conduct research that will assist law enforcement and criminal justice agencies in the selection and procurement of quality equipment.

OLES is: (1) subjecting existing equipment to laboratory testing and evaluation, and (2) conducting research leading to the development of several series of documents, including national standards, user guides, and technical reports.

This document covers research conducted by OLES under the sponsorship of the National Institute of Justice. Additional reports as well as other documents are being issued under the OLES program in the areas of protective clothing and equipment, communications systems, emergency equipment, investigative aids, security systems, vehicles, weapons, and analytical techniques and standard reference materials used by the forensic community.

Technical comments and suggestions concerning this document are invited from all interested parties. They may be addressed to the Director, Office of Law Enforcement Standards, National Institute of Standards and Technology, Gaithersburg, MD 20899-8102.

Dr. David G. Boyd, Director  
Office of Science and Technology  
National Institute of Justice



## BACKGROUND

The Office of Law Enforcement Standards (OLES) was established by the National Institute of Justice (NIJ) to provide focus on two major objectives: (1) to find existing equipment which can be purchased today, and (2) to develop new law-enforcement equipment which can be made available as soon as possible. A part of OLES's mission is to become thoroughly familiar with existing equipment, to evaluate its performance by means of objective laboratory tests, to develop and improve these methods of test, to develop performance standards for selected equipment items, and to prepare guidelines for the selection and use of this equipment. All of these activities are directed toward providing law enforcement agencies with assistance in making good equipment selections and acquisitions in accordance with their own requirements.

As the OLES program has matured, there has been a gradual shift in the objectives of the OLES projects. The initial emphasis on the development of standards has decreased, and the emphasis on the development of guidelines has increased. For the significance of this shift in emphasis to be appreciated, the precise definitions of the words "standard" and "guideline" as used in this context must be clearly understood.

A "standard" for a particular item of equipment is understood to be a formal document, in a conventional format, that details the performance that the equipment is required to give and describes test methods by which its actual performance can be measured. These requirements are technical and are stated in terms directly related to the equipment's use. The basic purposes of a standard are (1) to be a reference in procurement documents created by purchasing officers who wish to specify equipment of the "standard" quality, and (2) to objectively identify equipment of acceptable performance.

Note that a standard is not intended to inform and guide the reader; that is the function of a "guideline." Guidelines are written in nontechnical language and are addressed to the potential user of the equipment. They include a general discussion of the equipment, its important performance attributes, the various models currently on the market, objective test data where available, and any other information that might help the reader make a rational selection among the various options or alternatives available.

Kathleen Higgins  
*National Institute of Standards and Technology*  
April 2001





# CONTENTS

FOREWORD .....	iii
BACKGROUND .....	v
FIGURES .....	viii
COMMONLY USED SYMBOLS AND ABBREVIATIONS .....	x
1. INTRODUCTION .....	1
1.1 Scope .....	1
1.2 Organization .....	1
2. LAND MOBILE RADIO .....	3
2.1 Users .....	3
2.2 Frequency Bands .....	3
2.3 Rules and Regulations .....	5
3. ANTENNA FUNDAMENTALS .....	7
3.1 History of the Antenna .....	7
3.2 Frequency and Wavelength .....	8
3.3 Radiation Principles .....	9
4. ANTENNA CHARACTERISTICS .....	11
4.1 Gain and Directivity .....	11
4.2 Radiation Pattern .....	12
4.3 Antenna Polarization .....	13
4.4 Antenna Terminal Impedance .....	13
4.5 Voltage Standing Wave Ratio .....	15
4.6 Effective Length and Effective Area .....	15
4.7 Bandwidth .....	16
5. ANTENNA TYPES .....	17
5.1 Dipoles and Monopoles .....	17
5.2 Base-Station Applications .....	18
5.3 Corner Reflector .....	20
5.4 Yagi .....	20
5.5 Log-Periodic .....	21
5.6 Arrays .....	22
5.7 Unusual Antennas .....	24
5.8 Active Antennas .....	25
5.9 Diversity Antennas .....	25
6. TRANSMISSION LINES AND OTHER COMPONENTS .....	27
6.1 Transmission Line Types .....	27
6.2 Baluns .....	28
6.3 Duplexers .....	29
6.4 Combiners .....	30
6.5 Intermodulation Suppression .....	30
6.6 Multicouplers .....	30

7. RADIO WAVE PROPAGATION .....	33
7.1 Transmission Loss and the Power Budget .....	33
7.2 Free-Space Basic Transmission Loss .....	34
7.3 Terrestrial Propagation .....	35
7.4 Co-Site Analysis .....	37
8. ANTENNA SYSTEM REQUIREMENTS AND DESIGN .....	39
8.1 Define System Requirements .....	39
8.2 Design System .....	41
8.3 Select Appropriate Components .....	41
9. INSTALLATION, MAINTENANCE, AND SAFETY .....	43
9.1 Vehicular Antenna Systems .....	43
9.2 Fixed-Site Antenna Systems .....	43
9.3 Lightning Protection .....	44
9.4 During Installation .....	44
9.5 Perform Routine Maintenance .....	45
10. ANTENNA SYSTEM RESOURCES .....	49
10.1 Internet Resources .....	49
10.2 Periodicals .....	49
10.3 Manufacturers' and Vendors' Catalogs .....	49
11. PROFESSIONAL AND STANDARDS ORGANIZATIONS .....	51
12. ACRONYMS .....	57
13. REFERENCES .....	59
14. ACKNOWLEDGMENTS .....	61

## FIGURES

Figure 1. Elements of a radio system .....	7
Figure 2. The propagation of a plane electromagnetic wave .....	10
Figure 3. The horizontal-plane and vertical-plane patterns of a vertical half-wavelength dipole .....	12
Figure 4. Vertical-plane radiation patterns [12] showing increasing complexity of lobes and nulls .....	13
Figure 5. The vertical dipole and its electromagnetic equivalent, the vertical monopole .....	17
Figure 6. Typical monopole antennas for (a) base-station applications and (b) mobile applications .....	18
Figure 7. Omnidirectional base-station antennas .....	18
Figure 8. A monopole antenna horizontal-plane pattern, base-station application. The uniform maximum gain corresponds to the outer line on the polar plot .....	18
Figure 9. A folded-dipole antenna .....	19
Figure 10. Typical mobile antennas .....	19
Figure 11. A mobile antenna horizontal-plane pattern [13] .....	20

Figure 12. Corner reflector antennas .....	20
Figure 13. A typical corner-reflector antenna .....	20
Figure 14. A corner-reflector antenna horizontal-plane pattern .....	20
Figure 15. The Yagi antenna — (a) three elements and (b) multiple elements .....	21
Figure 16. A typical Yagi antenna .....	21
Figure 17. A Yagi antenna horizontal-plane pattern .....	21
Figure 18. A log-periodic antenna .....	22
Figure 19. A typical log-periodic antenna .....	22
Figure 20. A log-periodic antenna horizontal-plane pattern .....	22
Figure 21. A typical vertical array using folded dipoles .....	23
Figure 22. Vertical-plane radiation patterns for (a) single half-wave dipole, (b) two-element array, and (c) three-element array .....	23
Figure 23. A coaxial collinear array .....	24
Figure 24. A vertical-plane radiation pattern without “tilt” .....	24
Figure 25. A vertical-plane radiation pattern with 8° “tilt” .....	24
Figure 26. A slot antenna .....	25
Figure 27. A simple active antenna .....	25
Figure 28. Common types of transmission lines .....	27
Figure 29. Coaxial cables commonly used for LMR — (a) base station applications and (b) mobile applications .....	28
Figure 30. A VHF duplexer .....	29
Figure 31. Typical types of combiners — (a) hybrid combiner and (b) cavity combiner .....	30
Figure 32. Intermodulation suppression device .....	30
Figure 33. A multicoupler .....	31
Figure 34. Gains and losses as described in the power-budget equation .....	33
Figure 35. A propagation path illustrating direct and reflected rays .....	35
Figure 36. An example of diffraction .....	36

## TABLE

Table 1. Characteristics of selected coaxial cable .....	29
--	----

### COMMONLY USED SYMBOLS AND ABBREVIATIONS

A	ampere	H	henry	nm	nanometer
ac	alternating current	h	hour	No.	number
AM	amplitude modulation	hf	high frequency	o.d.	outside diameter
cd	candela	Hz	hertz	$\Omega$	ohm
cm	centimeter	i.d.	inside diameter	p.	page
CP	chemically pure	in	inch	Pa	pascal
c/s	cycle per second	IR	infrared	pe	probable error
d	day	J	joule	pp.	pages
dB	decibel	L	lambert	ppm	parts per million
dc	direct current	L	liter	qt	quart
$^{\circ}$ C	degree Celsius	lb	pound	rad	radian
$^{\circ}$ F	degree Fahrenheit	lbf	pound-force	rf	radio frequency
dia	diameter	lbf•in	pound-force inch	rh	relative humidity
emf	electromotive force	lm	lumen	s	second
eq	equation	ln	logarithm (base e)	SD	standard deviation
F	farad	log	logarithm (base 10)	sec.	section
fc	footcandle	M	molar	SWR	standing wave ratio
fig.	figure	m	meter	uhf	ultrahigh frequency
FM	frequency modulation	min	minute	UV	ultraviolet
ft	foot	mm	millimeter	V	volt
ft/s	foot per second	mph	miles per hour	vhf	very high frequency
g	acceleration	m/s	meter per second	W	watt
g	gram	N	newton	$\lambda$	wavelength
gr	grain	N•m	newton meter	wt	weight

area=unit<sup>2</sup> (e.g., ft<sup>2</sup>, in<sup>2</sup>, etc.); volume=unit<sup>3</sup> (e.g., ft<sup>3</sup>, m<sup>3</sup>, etc.)

### PREFIXES

d	deci (10 <sup>-1</sup> )	da	deka (10)
c	centi (10 <sup>-2</sup> )	h	hecto (10 <sup>2</sup> )
m	milli (10 <sup>-3</sup> )	k	kilo (10 <sup>3</sup> )
$\mu$	micro (10 <sup>-6</sup> )	M	mega (10 <sup>6</sup> )
n	nano (10 <sup>-9</sup> )	G	giga (10 <sup>9</sup> )
p	pico (10 <sup>-12</sup> )	T	tera (10 <sup>12</sup> )

### COMMON CONVERSIONS (See ASTM E380)

0.30480 m = 1 ft	4.448222 N = 1 lbf
2.54 cm = 1 in	1.355818 J = 1 ft•lbf
0.4535924 kg = 1 lb	0.1129848 N m = 1 lbf•in
0.0647989 l g = 1 gr	14.59390 N/m = 1 lbf/ft
0.9463529 L = 1 qt	6894.757 Pa = 1 lbf/in <sup>2</sup>
3600000 J = 1 kW•hr	1.609344 km/h = 1 mph

Temperature:  $T_{^{\circ}\text{C}} = (T_{^{\circ}\text{F}} - 32) \times 5/9$

Temperature:  $T_{^{\circ}\text{F}} = (T_{^{\circ}\text{C}} \times 9/5) + 32$

# 1. INTRODUCTION

Radio communications are essential to the operations of Federal, State, and local law enforcement and correction agencies. Effective and reliable communications systems not only enable personnel to perform their functions efficiently, but also help ensure their safety. It is, therefore, very important that all components of a radio communications system be selected and integrated to produce an effective design. Understanding the capabilities and limitations of a communications system ensures that it is used most effectively and that performance expectations are realistic.

This guide focuses on a key portion (subsystem) of the radio communications system—the antenna system. Although the antenna itself may be the most visible element of radio communications equipment, it is often the least understood. This guide defines and describes the components of the antenna system as well as the fundamentals and characteristics of the antenna itself.<sup>1</sup>

## 1.1 Scope

The theory and empiricism upon which antenna technology is based are very complex. It is not the purpose of this guide to tutor the reader in the study of electromagnetic theory. Rather, it is to provide the reader with sufficient understanding of the fundamentals, characteristics, and functions of antennas to

enable him or her to develop requirements and discuss antennas with vendors, installers, repair shops, *etc.* To this end, the number of equations and references to theory are kept to a minimum, and the information is generally restricted to the kind of antennas used by law enforcement agencies.

This guide is intended for a wide audience. It is written so that the reader can study only those sections of interest. Cross-referencing is provided where needed to direct the reader to related, important information.

## 1.2 Organization

Section 2 of this guide provides the reader with a brief description of land mobile radio (LMR), which is the radio service used by nearly all law enforcement agencies. The frequency bands used by LMR are described. The information provided on antennas in this guide is generally limited to LMR applications and the radio frequencies used by LMR.

Section 3 begins with an overview of the major elements of a radio communications system. The function of the antenna (sub)system is described. The remainder of the section provides a brief history of the antenna and an introduction to the fundamentals of antennas and radio wave propagation. Several of the subsections are important to the understanding of antennas. These are section 3.2 on frequency and wavelength and section 3.3 on radiation principles. The reader is encouraged to review the simple, but important, concepts in these subsections to fully understand the following sections.

---

<sup>1</sup> Certain commercial companies and their products and information are identified in this report to specify adequately the technical concepts and principles being presented. In no case does such identification imply recommendation or endorsement by the National Institute of Justice, or any other U.S. Government department or agency, nor does it imply that the sources, products, and information identified are necessarily the best available for the purpose.

Section 4 is the most important part of this guide, as it presents the engineering, or functional, characteristics of antennas. It defines gain, directivity, and radiation pattern and how these are used in a radio communications system design. These and other characteristics are also used to specify an antenna. Section 5 contains descriptions of common antennas including their electrical and radiation characteristics as well as their physical characteristics. Although there are many different kinds of antennas, the emphasis is on those antennas commonly used for LMR.

Sections 6 and 7 relate to the use of antennas within a radio communications system. Section 6 describes the transmission lines and related components needed to connect an antenna to a transmitter or a receiver, and section 7 describes the modes of radio wave propagation commonly used for LMR systems. Section 7 also discusses how an antenna pattern and propagation effects are used to achieve required geographical coverage.

The next three sections (8, 9, and 10) cover the practical aspects of developing and expressing requirements for an antenna; the installation, maintenance, and safety of antennas; and examples of some of the products and services available, respectively.

Section 11 provides the reader with a list of the relevant regulatory, standards, and professional organizations. The last two sections (12 and 13) provide reference material. Section 12 is a list of acronyms used in this guide or related to antennas. Section 13 contains the references cited in this guide.

## 2. LAND MOBILE RADIO

The formal title of the type of radio service used by law enforcement agencies for their radio communications is “land mobile service,” and the frequency bands reserved for their use are labeled “public safety.” Land mobile service is defined as “a mobile radio service between base stations and land mobile stations, or between land mobile stations,” by the National Telecommunications and Information Administration (NTIA) [1]<sup>2</sup> and the Federal Communications Commission (FCC) [2]. Another commonly used phrase for “land mobile service” is “land mobile radio” (LMR).

### 2.1 Users

There are two general classes of users. One class of users is radio common carrier (RCC). RCC owners build and operate LMR systems and charge a fee to third parties that actually use the system. The other class of users includes groups that meet specific requirements for LMR use. These groups include: Public Safety Radio Services, Special Emergency Radio Services, Industrial Radio Services, Land Transportation Radio Services, Radio Location Services, and Specialized Mobile Radio Services. The first group listed here, the Public Safety Radio Services, is the category that includes State and local governments, law enforcement and corrections, fire, emergency medical services, highway maintenance, and forestry conservation. Federal law enforcement and corrections agencies also belong to this category of LMR users. These Federal agencies may use some of the same frequency bands and

channels as State and local agencies, but, in many cases, they use frequency bands and channel assignments unique to the Federal Government.

Most LMR user groups maintain formal associations that provide for the exchange of information within their groups and represent their members before the FCC and other official or government bodies. Those associations relevant to the law enforcement community include the Association of Public-Safety Communications Officials (APCO), the National Association of State Telecommunications Directors (NASTD), and the Telecommunications Industry Association (TIA). The first two of these represent the users, and the last represents the manufacturers of the equipment used for LMR. More details on these associations and other relevant organizations are presented in section 11.

### 2.2 Frequency Bands

There are a number of frequency bands allocated for use by LMR. The particular frequency ranges for these bands have been established at the international level, in plenipotentiary conferences, by the International Telecommunications Union (ITU). Administration and assignment of frequencies within the LMR bands in the United States are performed by two different government agencies. The FCC provides frequency assignments and licenses for all non-Federal users. Federal users obtain their frequency assignments through NTIA.

The LMR bands described in the following sections are subdivided for Federal use only, shared Federal and non-Federal use, and

---

<sup>2</sup> Numerals in square brackets refer to references identified in section 13.

non-Federal use only. Portions of some bands may be shared with other services such as maritime mobile, mobile satellite, and broadcast television.

### **2.2.1 VHF Low-Band**

This band is located at 25 MHz to 50 MHz and generally uses channels 20 kHz wide. Communications ranges can be the greatest in this band; however, the radio signals do not reflect effectively off hills, buildings, and other surfaces, so there may be dead spots within the general area of coverage of a base station. These frequencies, especially at the lower end of the band, are subject to ionospheric "skip," which can carry a signal very long distances (and cause interference to other users). This band also has the highest level of ambient noise, which reduces the performance of receivers operating in this band compared to other, higher frequency-bands.

### **2.2.2 VHF High-Band**

This band is located at 150 MHz to 174 MHz and uses channels 25 kHz or 30 kHz wide. Adjacent channels may be separated by 12.5 kHz to 15 kHz for geographically separated systems. Radio signals in this band have a shorter propagation range, experience less noise than those in the VHF low-band, and are not subject to ionospheric "skip." Diffraction over hills and around other obstacles reduces dead areas of coverage.

### **2.2.3 UHF Bands**

The first UHF band is located at 406 MHz to 420 MHz and is designated for Federal usage. The second band is located at 450 MHz to 470 MHz and is designated for non-Federal usage. The last band, from

470 MHz to 512 MHz, shares spectrum with UHF television channels 14 through 20 in a few major urban areas. Channels in all three UHF bands are 25 kHz wide. The propagation range in the UHF band is even less than that found in the VHF high-band; however, the radio signals easily reflect off hills and buildings, so dead areas are generally very small.

### **2.2.4 700 MHz Band**

New bands from 764 MHz to 776 MHz and 794 MHz to 806 MHz have been proposed by the FCC. These new channels would be converted from TV channels 63-64 and 68-69 to Public Safety use. The channels would be either narrowband for voice plus low-speed data or wideband (up to 150 kHz) for high-speed data.

### **2.2.5 800/900 MHz Band**

The portion of the radio spectrum from 806 MHz to 940 MHz is apportioned among many services, including cellular telephone, paging, nonpublic safety, and conventional and trunked public safety. Federal Government users, however, have no authorizations in this spectrum. Channels for public safety are reserved in blocks that are generally 25 kHz wide. These blocks reside in several locations within this portion of the radio spectrum. These radio signals reflect off hills, buildings, vehicles, *etc.*, well enough that dead areas are nearly nonexistent. The propagation range for this band is shorter than for the UHF bands.



## 2.3 Rules and Regulations

### 2.3.1 General

In the United States, the FCC allocates different bands of the radio-frequency spectrum to different entities for a wide variety of commercial and private applications [2]. The NTIA performs this function for the Federal Government. In recent years, with the proliferation of portable phones and other mobile communications devices, the FCC and the NTIA have received an increasing number of requests for an ever-dwindling amount of spectrum available for allocation.

One way that the FCC and NTIA attempt to maximize spectrum usage is to assign the right to transmit over the same channel to different commercial or private groups that are located in different geographic regions, so that their signal coverage areas will not overlap. Consideration is also given when assigning adjacent channels, so signals from one transmission channel will not affect adjacent channels.

Further description of the allocation process and the most recent listing of allocations can be found in the *NTIA Manual of Regulations and Procedures for Federal Radio Frequency Management* [1] and the *Code of Federal Regulations* [3] pertaining to telecommunications.

### 2.3.2 Future Options

At the present time, LMR bands are crowded and channel assignments can be difficult to obtain in some areas of the country. For this reason, work is underway to develop new, spectrally efficient modulation and signal-processing methods and improved techniques to share existing channels. Historically, this problem has been addressed by making narrower channels within a band. Frequency-modulation (FM) systems have been improved to allow them to operate in bandwidths as small as 12.5 kHz. Further improvement requires different modulation methods, but care must be taken in choosing and standardizing the modulation method and channel widths to ensure interoperability among different systems and equipment from different manufacturers.

New LMR systems conforming to the "Project 25" standard [4] use narrowband modulation techniques and channel-sharing methods (called trunking). These new digital modulation methods will be able to use channels as narrow as 6.25 kHz. Trunking techniques will accommodate two, three, or more times as many users for a given number of channels.



### 3. ANTENNA FUNDAMENTALS

The antenna is often the most visible element of a radio system. The sizes and shapes of the conductors that comprise the antenna determine the directional characteristics of the electromagnetic (radio) waves it radiates. However, the antenna cannot be considered independently. Additional elements, such as the transmission line, duplexers, matching networks, *etc.*, must be considered as part of the *antenna system*.

The full description of the interaction of an antenna with its surrounding environment is based on very complex mathematics, but its function in a radio system is quite simple. Figure 1 shows the key elements of a radio communications system. When an antenna is used for transmitting, it converts electrical signals, delivered by a transmission line, from a transmitter into propagating electromagnetic waves. When an antenna is used for receiving, it converts electromagnetic waves back into electrical signals that are delivered by a transmission line to a receiver for processing. In fact, the

same antenna (used for both transmitting and receiving) is often attached to a transmitter and a receiver using either a *duplexer* or a *transmit/receive (XMT/RCV) switch*. A duplexer allows one antenna to be used by both the transmitter and receiver at the same time (see sec. 6.3), and a transmit/receive switch connects the antenna to either the transmitter or receiver.

#### 3.1 History of the Antenna

Over a century has elapsed since James Clerk Maxwell [5] formulated his celebrated equations that provide the foundation of classical electromagnetism. By means of these equations, Maxwell was able to predict the existence of electromagnetic waves which, 20 years later in 1887, were confirmed experimentally by Heinrich Hertz [6]. Hertz constructed a center-driven wire about 60 cm long, terminated at each end by a 40 cm square metal plate. Driven by a spark-gap generator (broadband source), this antenna resonated at about 50 MHz and effectively generated and radiated

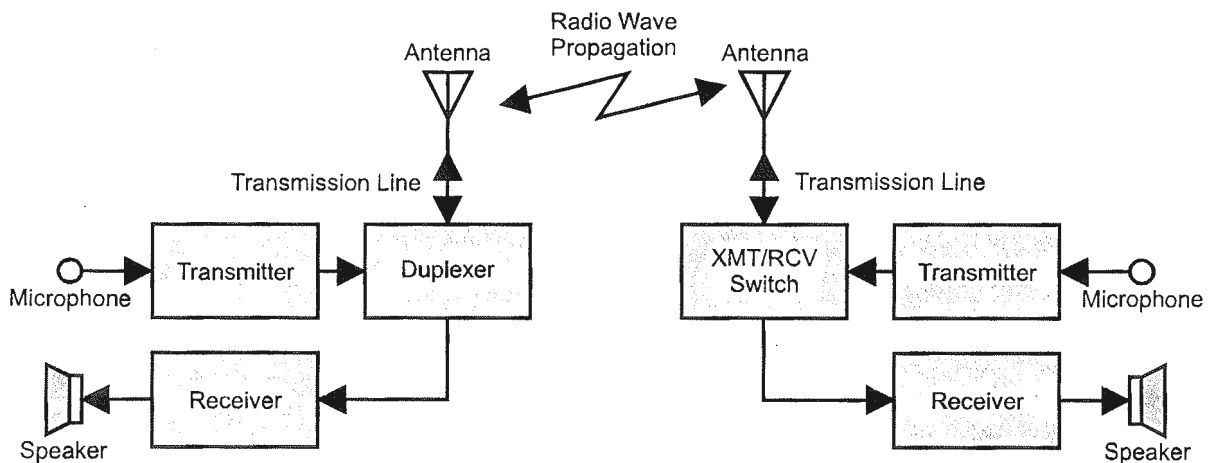


Figure 1. Elements of a radio system

electromagnetic waves. He detected those waves using a loop of wire, 35 cm in radius, with a very small gap where he could observe a spark. Although a number of researchers became interested in this new phenomenon, it was Guglielmo Marconi who, in 1897, described and then demonstrated a complete system for the *transmission of signals*. On December 12, 1901, the first transatlantic communication was achieved. The transmitting antenna in Cornwall, England, was a fan-like structure of 50 copper wires supported by a horizontal wire stretched between two poles about 45 m high and 65 m apart. The receiving antenna in Newfoundland was comprised of copper wires supported by kites. By 1907, commercial, transatlantic telegraph services had been established [7].

It is interesting to note that the original, commonly used term for a signaling system that uses the phenomenon of electromagnetic waves was “wireless.” Although the term “radioconductor” (a contraction of radiation conductor) appears as early as 1897, the term “radio” does not emerge until later. The Radio Ship Act of 1910 contains the terms “radio” and “radio-communication” but not “wireless.” In 1912, the U.S. Navy directed the use of the term “radio” in place of “wireless” [8].

### 3.2 Frequency and Wavelength

A propagating electromagnetic wave exists because of the fundamental interdependence of the electric and magnetic fields that comprise it. An electric field that changes with time produces a magnetic field whose strength is determined by the *rate of change* of the electric field. And, in complementary fashion, a magnetic field that changes with time produces an electric field whose

strength is determined by the *rate of change* of the magnetic field. This means that the energy contained in, and transmitted by, the radio wave is shared by the two fields.

When transmitting, the electrical current on an antenna produces the magnetic field, and the voltage on that antenna produces the electric field. Similarly, when receiving, an electromagnetic wave incident on the antenna produces electrical current and voltage. If these currents and voltages have a sinusoidal time dependence (sine or cosine wave), then several very important, fundamental phenomena occur. The first derivative (rate of change) of a sine wave is another sine wave shifted in time by one quarter of the period of the first sine wave. This means that if the changing electric field in the radio wave is sinusoidal, then so is the magnetic field. These two sinusoidal time-varying fields, in effect, regenerate each other as they travel. This is called wave propagation.

The frequency of a sine wave is expressed as the number of cycles per second or *hertz*. The period of the wave is the reciprocal of its frequency and is expressed in seconds. The wavelength is the length of one cycle of the traveling wave in space, or the distance the wave travels during one period. The relationship between frequency and wavelength is

$$\lambda = \frac{c}{f} \quad (1)$$

where  $\lambda$  is the wavelength (m),  $c$  is the speed of light ( $2.9979 \times 10^8$  m/s), and  $f$  is the frequency (Hz). A practical, approximate version of this equation is

$$\lambda \approx \frac{300}{f} \quad (2)$$

where  $\lambda$  is in meters and  $f$  is in megahertz.

### 3.3 Radiation Principles

The important characteristics of an antenna are its radiation properties, such as *gain*, *directionality*, and *polarization*; and the electrical property, *input impedance*. These and other characteristics can be determined theoretically, or they can be obtained by measurement. In practice, both theory and measurement are used to design or evaluate an antenna.

The remainder of this section is necessary to the understanding and usefulness of section 4, Antenna Characteristics. Although based in electromagnetic theory, these fundamental principles are not complicated and they are essential to an understanding of antennas.

#### 3.3.1 What Is an Antenna?

An antenna is a device that provides suitably localized and oriented paths for oscillating electric currents. The sizes and shapes of the conductors that comprise the antenna determine the directional characteristics of the radio waves it radiates. A transmitting antenna converts electrical currents, delivered by the transmission line from a transmitter, into propagating radio waves, and a receiving antenna converts radio waves back into electrical currents that are delivered by a transmission line to a receiver.

#### 3.3.2 Reciprocity

The theoretical determination of an antenna's characteristics is usually accomplished by treating the antenna as a transmitting device.

However, under most conditions, the antenna characteristics are exactly the same when it is used as a receiving device. If the antenna is *linear* (i.e., it contains neither active elements nor nonlinear components such as ferrites), then the *principle of reciprocity* holds. This principle was first described by the famous mathematician Lord Rayleigh [9]. The principle of reciprocity means that an antenna will have exactly the same characteristics whether it is used for transmitting or receiving. So, if a particular characteristic of an antenna is obtained by measurement while using the antenna for reception, then it is known that the same antenna will have exactly the same characteristic when used for transmission.

#### 3.3.3 Radiated Waves and the Near Field

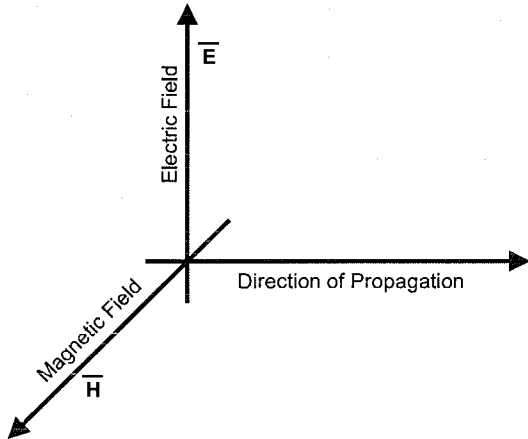
The electromagnetic field produced by an antenna is quite complex near the antenna, and it can be described as having several components. Only one of these actually propagates, or travels through space. This component is called the radiated field, radiated wave, or radio wave. The propagation of this radiated field, or radio-wave propagation, is usually treated as a separate topic. The strength of the radiated field does decrease with distance, as it must, since the energy must spread as it travels. Some knowledge of propagation is useful in understanding antennas or in choosing an antenna to meet certain requirements, such as coverage—the area over which a radio wave has sufficient strength to be useful. Section 7 presents a brief overview of radio-wave propagation.

The other components of the electromagnetic field remain near the antenna and do not propagate. There are generally two

other components: the static field and the induction field. Even though they do not propagate, their strength decreases very rapidly with distance. The entire field—all of the components—near the antenna is called the *near field*. In this region, approximately one wavelength in extent, the field strength can be relatively high and pose a hazard to the human body. See section 9.5.4 for more information on this *radiation hazard*.

### 3.3.4 Plane Waves

The radiated wave, as with all electromagnetic waves including light, is composed of an electric field and a magnetic field. For most cases, the field lines, and the vectors that are used to illustrate them, are at a right angle to each other and to the direction of propagation, as shown in figure 2.



*Figure 2. The propagation of a plane electromagnetic wave*

At large distances from the antenna, say beyond ten wavelengths, the radiated field is essentially a *plane wave*. This means that there is no curvature of the field lines.

### 3.3.5 Wave Polarization

The polarization of a wave, by definition, is simply the orientation of the electric field vector. The plane wave depicted in the illustration of figure 2 is vertically polarized. For nearly all cases encountered in LMR, the polarization of the wave does not change as it propagates. This is called *linear polarization*, and the two most common examples in practice are vertical or horizontal polarization. Other polarizations include circular, where the electric field vector (and the magnetic field vector) rotate as the wave travels.

## 4. ANTENNA CHARACTERISTICS

In a radio communications system, an antenna has two basic functions. The primary function is to radiate, as radio waves, the RF signals from the transmitter, or to convert radio waves into RF signals for processing by a receiver. The other function is to direct the radiated energy in the desired direction or directions, or to be “sensitive” to reception from the desired direction or directions. Another, often overlooked, aspect of an antenna’s directional properties is the suppression of radiation in undesired directions, or the rejection of reception from undesired directions.

The directional characteristics of an antenna are fundamental to an understanding of the antenna and how it is used in a radio communications system. These interrelated characteristics include *gain*, *directivity*, *radiation (antenna) pattern*, and *polarization*. Other characteristics such as *beamwidth*, *effective length*, and *effective aperture* are derived from the four listed above. *Terminal (input) impedance* is one other characteristic that is of fundamental importance. It is necessary to know the impedance of an antenna in order to efficiently couple the transmitter’s output power into it, or to efficiently couple the power from it into the receiver. All of these antenna characteristics are a function of frequency.

### 4.1 Gain and Directivity

The gain of an antenna is the radiation intensity<sup>3</sup> in a given direction divided by the radiation intensity that would be obtained if

---

<sup>3</sup> Radiation intensity is defined as the power density in terms of power per unit solid angle.

the antenna radiated all of the RF power delivered to it equally in all directions [10, 11]. Note that this definition of gain requires the concept of an isotropic radiator; that is, one that radiates the same power in all directions. Examples of nondirectional sources can be achieved (at least approximately) with sound and light; these are sometimes called point sources.

An isotropic antenna, however, is just a concept, because all practical radio antennas must have some directional properties. Nevertheless, the isotropic antenna is very important as a reference. It has a gain of unity ( $g = 1$  or  $G = 0$  dB) in all directions, since all of the power delivered to it is radiated equally well in all directions.

Although the isotrope is a fundamental reference for antenna gain, another commonly used reference is the dipole. In this case the gain of an ideal (lossless) half-wavelength dipole is used. Its gain is 1.64 ( $G = 2.15$  dB) relative to an isotropic radiator.

The gain of an antenna is usually expressed in decibels (dB). When the gain is referenced to the isotropic radiator, the units are expressed as dBi; but when referenced to the half-wave dipole, the units are expressed as dBd. The relationship between these units is

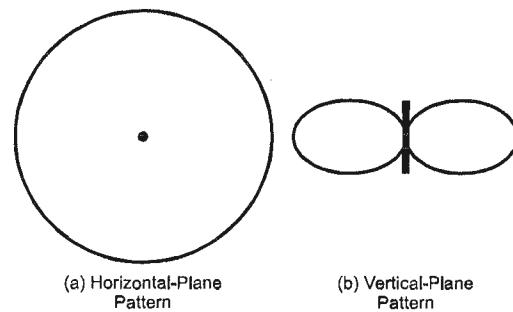
$$G_{dBd} = G_{dBi} - 2.15 \text{ dB} \quad (3)$$

*Directivity* is the same as gain, but with one difference. It does not include the effects of power lost (inefficiency) in the antenna itself. Recall that the definition of gain is based on

the power delivered to (and accepted by) the antenna. In practice, some of that power is lost in the antenna due to ohmic losses (heating) in the elements, leakage across insulators, *etc.* If an antenna were lossless (100 % efficient), then the gain and directivity (in a given direction) would be the same.

## 4.2 Radiation Pattern

The *radiation pattern* (also called *antenna pattern*) is a representation of the gain of an antenna for all directions. Since this is a three-dimensional description of the power density, it is difficult to display or use. It is common to display or plot cross-sections of it. Figure 3 shows the radiation pattern of a vertical half-wavelength dipole in the horizontal plane and a vertical plane. As one can see in this figure, the pattern in the horizontal plane has no structure. This antenna has constant gain versus azimuth. On the other hand, the pattern in a vertical plane shows that the antenna has maximum gain in the horizontal plane and no radiation in the directions coincident with the axis of the antenna. Therefore, one can now visualize the three-dimensional pattern as a torus (doughnut shaped).



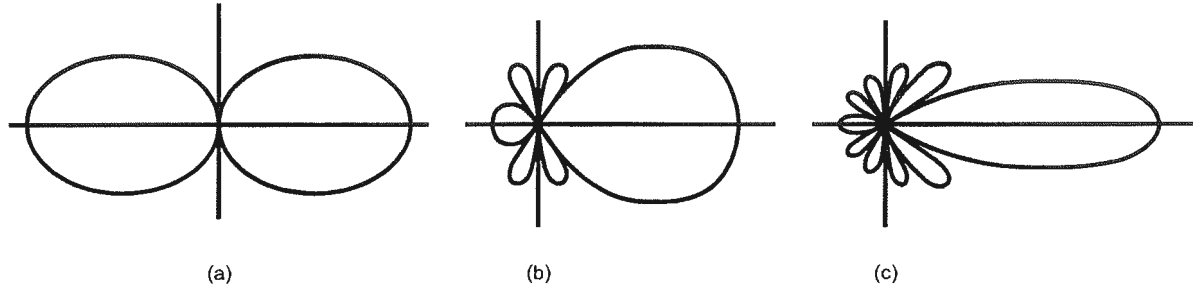
**Figure 3. The horizontal-plane and vertical-plane patterns of a vertical half-wavelength dipole**

Often, the direction is not specified when referring to an antenna's gain. In this case, it is assumed that the gain's direction is the direction of maximum radiation—the maximum gain for the antenna. An associated pattern then will present values relative to that maximum gain.

### 4.2.1 Lobes and Nulls

The regions of a pattern where the gain has local maxima are called *lobes*, and those places where the gain has local minima are called *nulls*. The vertical plane "cut" for the half-wave dipole (fig. 3b) has two lobes and two nulls. Figure 4 shows several other examples. A complex antenna pattern may have many lobes and nulls in both the horizontal-plane and vertical-plane patterns. The lobe with the greatest gain is called the *main lobe* or *main beam* of the antenna. If a single value of gain is given for an antenna, it is assumed to be the main lobe or *main beam gain*.





**Figure 4. Vertical-plane radiation patterns [12] showing increasing complexity of lobes and nulls**

#### 4.2.2 Beamwidth

Beamwidth is an angular measure of the *main lobe* (or main beam) in either (or both) the horizontal-plane or vertical-plane pattern [11]. There are several definitions for beamwidth, including: *half-power* or *3 dB beamwidth*, *10 dB beamwidth*, and *first-null beamwidth*. The 3 dB beamwidth is the angular extent about the maximum value of gain for which the gain is 3 dB below the maximum. First-null beamwidth is the angular extent about the maximum value of gain of the first occurring local minima in the pattern. The half-power, or 3 dB, beamwidth is most commonly used.

#### 4.3 Antenna Polarization

The term *polarization* has several meanings. In a strict sense, it is the orientation of the electric field vector  $E$  at some point in space. If the  $E$ -field vector retains its orientation at each point in space, then the polarization is linear; if it rotates as the wave travels in space, then the polarization is circular or elliptical. In most cases, the radiated-wave polarization is linear and either vertical or horizontal. At sufficiently large distances from an antenna, *e.g.*, well beyond 10 wavelengths, the radiated, far-field wave is a plane wave (see sec. 3.3.4).

The term polarization is often applied to the antenna itself. In this sense, the *polarization of the antenna* is the polarization of the plane wave it radiates. Based on the principle of reciprocity (see sec. 3.3.2), this is true for a receiving antenna, as well. For example, if a receiving antenna is vertically polarized, this means that a vertically polarized, incoming wave will produce maximum output from that antenna. If the incoming wave were polarized at some other angle, only the vertical component would be detected by the antenna. Ideally, a horizontally polarized incoming wave would not be detected at all by a vertically polarized antenna. Vertical polarization is used for most LMR applications.

#### 4.4 Antenna Terminal Impedance

There are three different kinds of impedance relevant to antennas. One is the *terminal impedance* of the antenna, another is the *characteristic impedance* of a transmission line, and the third is *wave impedance*.

Antenna terminal impedance is discussed in this section. Transmission line characteristic impedance is discussed in section 6, and wave impedance is the ratio of the electric field strength to the magnetic field strength of a propagating wave (see sec. 3.2 and sec. 3.3.4).

Terminal impedance is defined as the ratio of voltage to current at the connections of the antenna (*i.e.*, the point where the transmission line is connected). The complex form of Ohm's law defines impedance as the ratio of voltage across a device to the current flowing through it. The terminal impedance is expressed mathematically as

$$Z = \frac{V}{I} \quad (4)$$

where  $Z$  is the impedance, in ohms,  $V$  is the voltage, in volts, and  $I$  is the current, in amperes, at the antenna terminals for a given frequency. Each of these variables can be expressed as a complex number, each with real and imaginary parts. Such complex numbers can also be expressed by using a magnitude and phase angle—this is called *phasor* notation.

The real part of the impedance is called the resistive component, and the imaginary part is called the reactive component. This is often expressed as

$$Z = R + jX \quad (5)$$

where  $R$  is the resistive (real) component,  $X$  is the reactive (imaginary) component, and  $j = \sqrt{-1}$ .

The most efficient coupling of energy between an antenna and its transmission line occurs when the characteristic impedance of the transmission line and the terminal impedance of the antenna are the same and have no reactive component. When this is the case, the antenna is considered to be *matched* to the line.

Matching usually requires that the antenna be designed so that it has a terminal impedance of about  $50 \Omega$  or  $75 \Omega$  to match the common values of available coaxial cable. A half-wave dipole can be shortened slightly to achieve this. For other antennas, it can be difficult to remove (reduce to zero) the reactive component. In these cases, a matching network is often made part of the antenna to change its complex terminal impedance into something that better matches a transmission line.

The resistive part  $R$  of the terminal impedance is the sum of two components and is expressed in ohms,

$$R = R_r + R_d \quad (6)$$

The *radiation resistance*  $R_r$  is the "effective load" that represents the power radiated by that antenna as radio waves, and the *dissipative resistance*  $R_d$  is the "load" into which power is lost. The efficiency of an antenna is the ratio of the power radiated to the total power delivered to the antenna. It can be expressed as

$$\text{Efficiency} = \frac{I^2 R_r}{I^2 R} = \frac{R_r}{R} \quad (7)$$

As discussed in section 4.1, the dissipative losses are due to ohmic losses (heating) in the antenna elements, leakage across insulators, and similar effects. Furthermore, it should be noted that the efficiency of an antenna can also be expressed as the ratio of the gain to the directivity (for a given direction).

#### 4.5 Voltage Standing Wave Ratio

The *standing wave ratio* (SWR), also known as the *voltage standing wave ratio* (VSWR), is not strictly an antenna characteristic, but is used to describe the performance of an antenna when attached to a transmission line. It is a measure of how well the antenna terminal impedance is matched to the characteristic impedance of the transmission line. Specifically, the VSWR is the ratio of the maximum to the minimum RF voltage along the transmission line. The maxima and minima along the lines are caused by partial reinforcement and cancellation of a forward-moving RF signal on the transmission line and its reflection from the antenna terminals.

If the antenna terminal impedance exhibits no reactive (imaginary) part and if the resistive (real) part is equal to the characteristic impedance of the transmission line, then the antenna and transmission line are said to be matched. If this is true, then none of the RF signal sent to the antenna will be reflected at its terminals. There is no standing wave on the transmission line and the VSWR has a value of one. However, if the antenna and transmission line are not matched, then some fraction of the RF signal sent to the antenna is reflected back along the transmission line. This causes a standing wave, characterized by maxima and minima, to exist on the line. In this case, the VSWR has a value greater than one.

The VSWR is easily measured with a device called an *SWR meter*. It is inserted in the transmission line and directly gives a value for the VSWR. At a VSWR value of 1.5, approximately 4 % of the power incident at the antenna terminals is reflected. At a value of 2.0, approximately 11 % of the incident power is reflected. VSWR values of 1.1 to

1.5 are considered excellent, values of 1.5 to 2.0 are considered good, and values higher than 2.0 may be unacceptable.

As stated above and elsewhere, an ideal match between the antenna and transmission line is desired; but this can often be achieved only for a single frequency. In practice, an antenna may be used for an entire frequency band, and its terminal impedance will vary across the band. In an antenna specification, either the impedance versus frequency across a band is given or the VSWR versus frequency is given.

#### 4.6 Effective Length and Effective Area

The *effective length* and the *effective area* (also called *effective aperture*) are alternative ways of expressing the gain of an antenna. These characteristics are most useful and meaningful when the antenna is used for receiving. Of course, due to the principle of reciprocity, these characteristics are the same if the antenna is used for transmitting.

The effective length defines the ability of an antenna to produce a voltage at its terminals from an incident electric field. It is defined as

$$\ell_e = \frac{V}{E} \quad (8)$$

where  $\ell_e$  is expressed in meters,  $V$  is the open circuit voltage in volts, and  $E$  is the electric field strength in volts/meter. This definition assumes that the polarization of the incident field and the antenna are the same. The effective length can also be computed from the gain and the radiation resistance.

Effective area, or aperture, is more commonly used than effective length. It is defined as

$$A_e = \frac{P_r}{p} \quad (9)$$

where  $P_r$  is the power available at the terminals of the antenna in watts, and  $p$  is the power density of the incident wave in watts per square meter. The relationship between effective area and gain is

$$A_e = \frac{\lambda^2}{4\pi} g \quad (10)$$

#### 4.7 Bandwidth

*Bandwidth* is the difference between two frequencies, or the frequency range, within which the performance of an antenna is acceptable. In other words, one or more characteristics (*e.g.*, gain, pattern, terminal impedance) have acceptable values between the bandwidth limits. For most antennas, gain and pattern do not change as rapidly with frequency as the terminal impedance does, so the latter is often used to describe the bandwidth of an antenna.

VSWR (see sec. 4.5) is a measure of the effect of mismatch between an antenna's terminal impedance and the transmission line characteristic impedance. Since the transmission line characteristic impedance hardly changes with frequency, VSWR is a useful, practical way to describe the effects of terminal impedance and to specify an antenna's bandwidth. For example, an antenna specification may give a plot of the VSWR across some frequency band. It will likely have a minimum value at about the middle of the band. Another way of specifying the bandwidth is a statement of the maximum VSWR within a band.

Half-wave dipoles, and similar antennas, have a narrow bandwidth. Other antennas, like the log-periodic, are designed specifically to be broadband.

## 5. ANTENNA TYPES

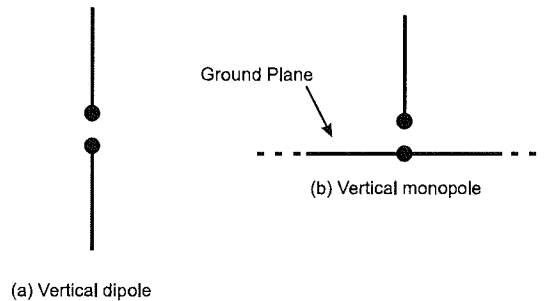
Antennas can be classified in several ways. One way is the frequency band of operation. Others include physical structure and electrical/electromagnetic design. The antennas commonly used for LMR—both at base stations and mobile units—represent only a very small portion of all the antenna types.

Most simple, nondirectional antennas are basic dipoles or monopoles. More complex, directional antennas consist of arrays of elements, such as dipoles, or use one active and several passive elements, as in the Yagi antenna.

New antenna technologies are being developed that allow an antenna to rapidly change its pattern in response to changes in direction of arrival of the received signal. These antennas and the supporting technology are called adaptive or “smart” antennas and may be used for the higher-frequency LMR bands in the future.

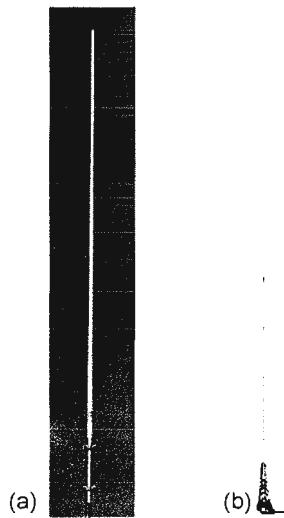
### 5.1 Dipoles and Monopoles

The vertical dipole—or its electromagnetic equivalent, the monopole—could be considered one of the best antennas for LMR applications. It is omnidirectional (in azimuth) and, if it is a half-wavelength long, has a gain of 1.64 (or  $G = 2.15$  dBi) in the horizontal plane. A center-fed, vertical dipole is illustrated in figure 5(a). Although this is a simple antenna, it can be difficult to mount on a mast or vehicle. The ideal vertical monopole is illustrated in figure 5(b). It is half a dipole placed in half-space, with a perfectly conducting, infinite surface at the boundary.



**Figure 5. The vertical dipole and its electromagnetic equivalent, the vertical monopole**

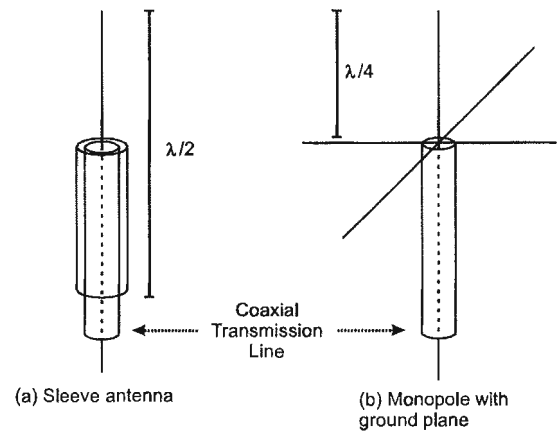
A monopole over an infinite ground plane is theoretically the same (identical gain, pattern, *etc.*, in the half-space above the ground plane) as the dipole in free space. In practice, a ground plane cannot be infinite, but a ground plane with a radius approximately the same as the length of the active element, is an effective, practical solution. The flat surface of a vehicle’s trunk or roof can act as an adequate ground plane. Figure 6 shows typical monopole antennas for base-station and mobile applications.



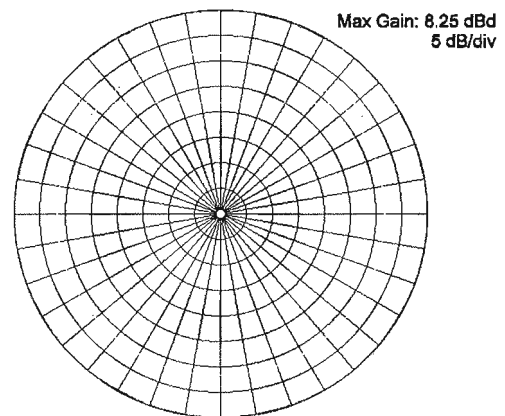
**Figure 6. Typical monopole antennas for (a) base-station applications and (b) mobile applications**

## 5.2 Base-Station Applications

For base-station installations (where an omnidirectional pattern is desired), there are two practical implementations of the vertical dipole. The first type is the sleeve antenna, as illustrated in figure 7(a). The sleeve antenna is a vertical dipole with the feed (transmission line) entering from one end of a hollow element. The second type is a monopole over a ground plane, as illustrated in figure 7(b). The monopole in this illustration uses a set of four wire elements to provide the ground plane. Figure 8 shows a typical pattern for a base-station monopole.



**Figure 7. Omnidirectional base-station antennas**



**Figure 8. A monopole antenna horizontal-plane pattern, base-station application. The uniform maximum gain corresponds to the outer line on the polar plot**

A variation of the dipole antenna is the folded dipole as shown in figure 9. Its radiation pattern is very similar to the simple dipole, but its impedance is higher and it has a wider bandwidth.

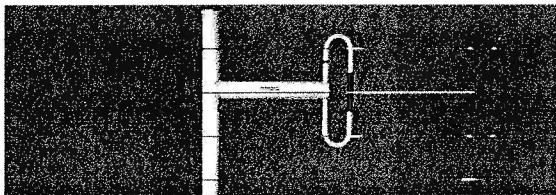


Figure 9. A folded-dipole antenna

### 5.2.1 Mobile Applications

Nearly all vehicular antennas are monopoles mounted over a (relatively) flat body surface (as described above). In this application, the monopole is often called a “whip” antenna. At VHF low-band, a quarter-wave monopole can be 2.5 m (approximately 8 ft) long. However, an inductor (coil) at the base of a monopole adds electrical length, so the physical length of the antenna can be shorter. Although this kind of “loaded” antenna will appear to be a quarter-wave antenna, it will have a gain value somewhat less than a true quarter-wave monopole. This disadvantage can be somewhat offset, however, by the ability to mount the (shorter) antenna in the center of a surface that will act as an acceptable ground plane (*e.g.*, the roof or trunk of the vehicle). Figure 10(a) shows an illustration of this kind of antenna.

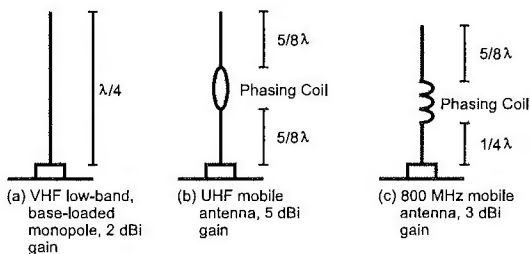


Figure 10. Typical mobile antennas

Many of the vehicular antennas at VHF high-band are quarter-wave monopoles. At

150 MHz, this would mean that a whip antenna, approximately 0.5 m (1.5 ft) long, is needed. Half-wave and 5/8 wave monopoles also are used, but they require some sort of matching network (*i.e.*, inductors and/or capacitors) in order to match the antenna impedance to that of the transmission line. These longer antennas have a gain of approximately 3 dBi.

At UHF, a quarter-wave whip is approximately 15 cm (6 in) long. Since this length is physically small, some design considerations can be used to increase the gain. For example, as shown in figure 10(b), two 5/8 wave monopoles can be “stacked” with a phasing coil between them. This is, effectively, an antenna array (see sec. 5.5) that provides a gain of approximately 5 dBi.

At 800 MHz, a quarter-wave monopole does not perform well, so the approach of stacking two monopoles, with a phasing coil between, is used. Such an antenna, illustrated in figure 10(c), looks much like a mobile cellular phone antenna and has a gain of approximately 3 dBi.

The azimuthal pattern of all monopoles is ideally a circle. In other words, the gain versus azimuth angle in the horizontal plane is constant. In practice, the pattern in the horizontal plane generally is not omnidirectional, since the portion of the vehicle used as a ground plane is not symmetric, and usually there are other obstructions. Figure 11 shows the horizontal plane pattern for an 840 MHz whip located in the center of the roof of a vehicle [13]. The dotted line in the figure shows the effects, on the pattern, of a law-enforcement light bar mounted on the roof ahead of the antenna.

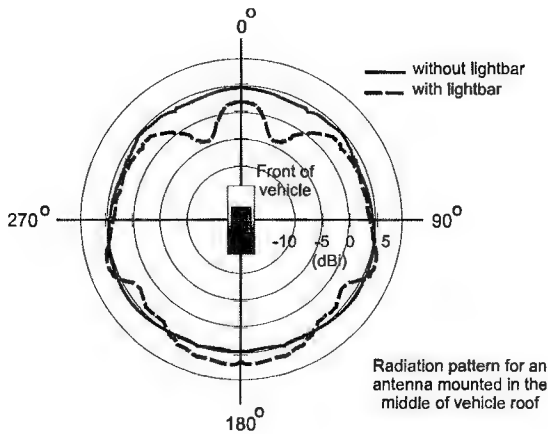


Figure 11. A mobile antenna horizontal-plane pattern [13]

### 5.3 Corner Reflector

An antenna comprised of one or more dipole elements in front of a corner reflector, called the corner-reflector antenna, is illustrated in figure 12. A photograph of a typical corner reflector is shown in figure 13.

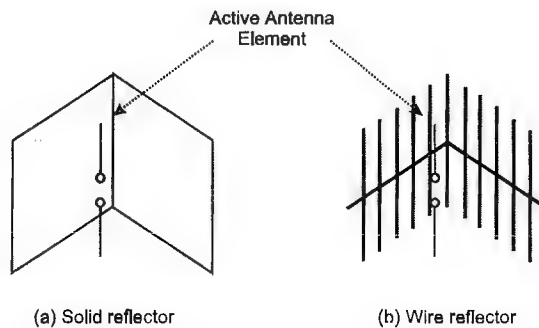


Figure 12. Corner-reflector antennas

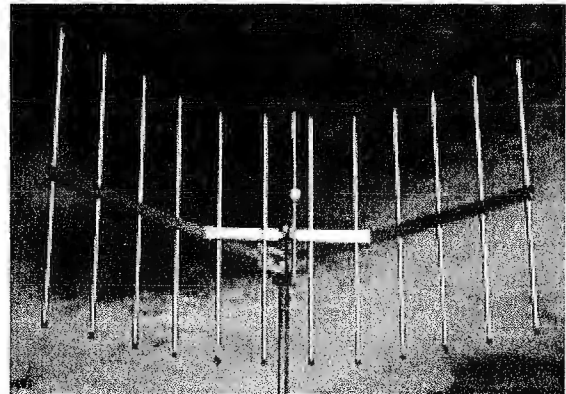


Figure 13. A typical corner-reflector antenna

This antenna has moderately high gain, but its most important pattern feature is that the forward (main beam) gain is much higher than the gain in the opposite direction. This is called the front-to-back ratio and is evident in the pattern shown in figure 14.

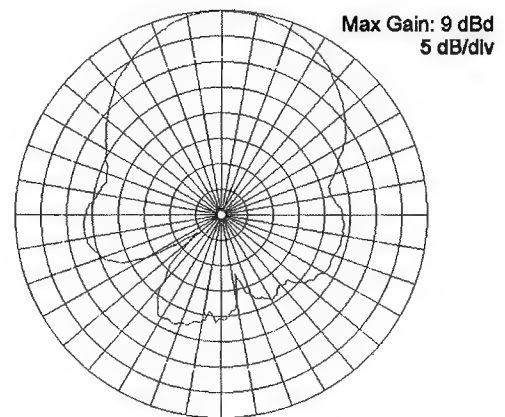


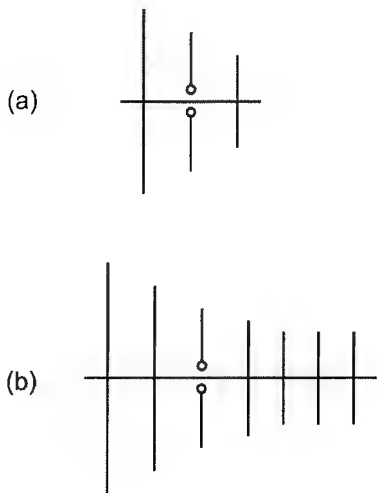
Figure 14. A corner-reflector antenna horizontal-plane pattern

### 5.4 Yagi

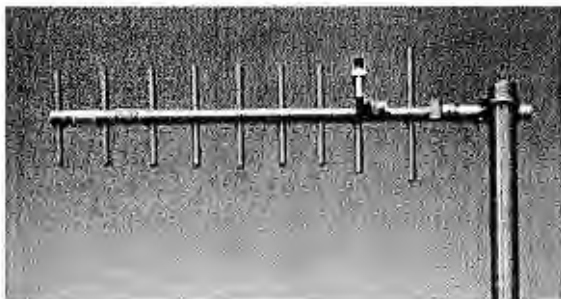
Another antenna design that uses passive elements is the Yagi antenna. This antenna, illustrated in figure 15, is inexpensive and effective. It can be constructed with one or



more (usually one or two) reflector elements and one or more (usually two or more) director elements. Figure 16 shows a Yagi antenna with one reflector, a folded-dipole active element, and seven directors, mounted for horizontal polarization.



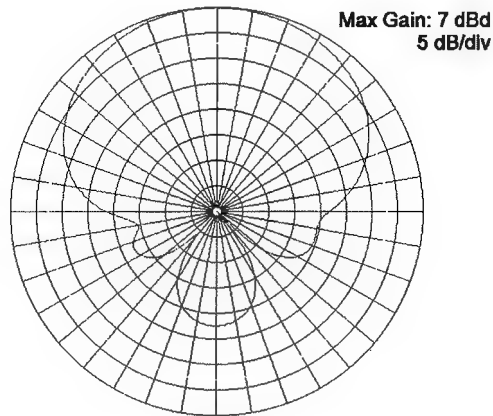
**Figure 15.** *The Yagi antenna — (a) three elements and (b) multiple elements*



**Figure 16.** *A typical Yagi antenna*

Figure 17 is a typical pattern for a three-element (one reflector, one active element, and one director) Yagi antenna. Generally, the more elements a Yagi has, the higher the gain, and the narrower the beamwidth. This

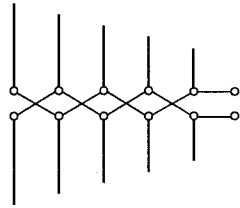
antenna can be mounted to support either horizontal or vertical polarization and is often used for point-to-point applications, as between a base station and repeater-station sites.



**Figure 17.** *A Yagi antenna horizontal-plane pattern*

### 5.5 Log-Periodic

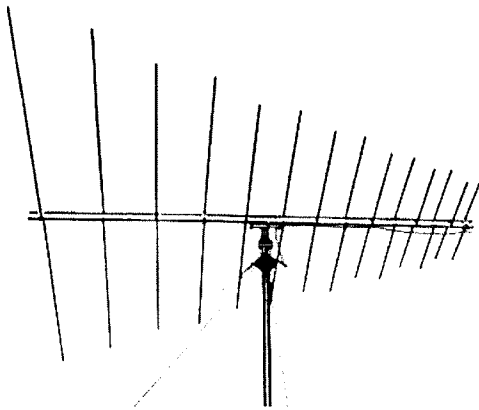
A somewhat novel, but very useful, design is the log-periodic antenna. This antenna is based on the dipole element. As shown in the illustration of figure 18, it is in fact comprised of a set of dipoles, all active, that vary in size from smallest at the front to largest at the rear. Usually, this antenna is constructed so the antenna terminals are located at the front (on the shortest dipole). Figure 19 shows a typical installation. The key features of this antenna are, first of all, its broadband nature, and second, its relatively high front-to-back gain ratio. The latter feature is evident in the typical radiation pattern shown in figure 20.



**Figure 18. A log-periodic antenna**

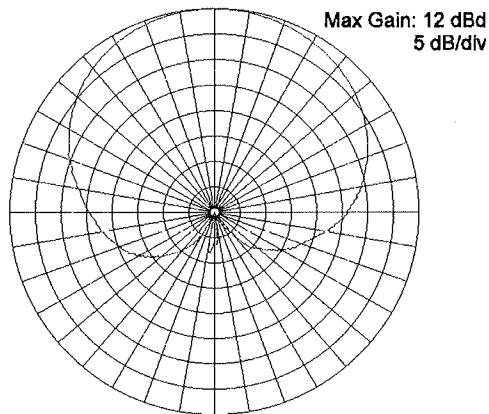
## 5.6 Arrays

An *antenna array* (or array antenna) is, much like it sounds, several elements interconnected and arranged in a regular structure to form an individual antenna. The purpose of an array is to produce radiation patterns that have certain desirable characteristics that a single element would not. A stacked dipole array, as shown in figure 21, is comprised of vertical dipole elements.

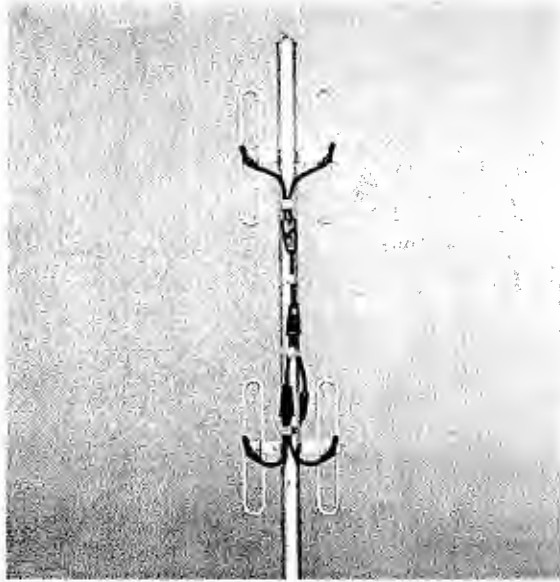


**Figure 19. A typical log-periodic antenna**

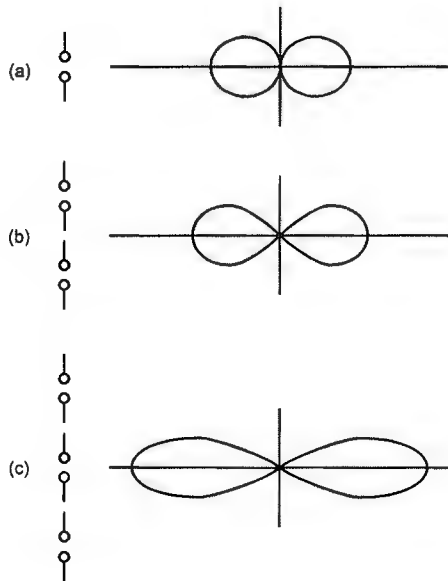
This dipole array has an omnidirectional pattern like the element dipole does; but has higher gain and a narrower main lobe beamwidth in the vertical plane. Figure 22 shows how the vertical-plane gain of the dipole element can be “enhanced” by making an array of them. Figure 22(a) represents the radiation pattern of one element. Figure 22(b) is the pattern of two elements, and figure 22(c) is for three elements.



**Figure 20. A log-periodic antenna horizontal-plane pattern**



**Figure 21.** A typical vertical array using folded dipoles



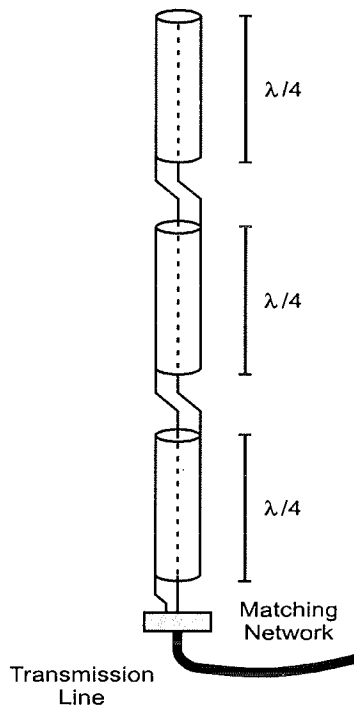
**Figure 22.** Vertical-plane radiation patterns for (a) single half-wave dipole, (b) two-element array, and (c) three-element array

This is called a binomial or collinear array [14]. As the number of elements is increased, the gain increases and the beamwidth decreases.

The omnidirectional coaxial collinear antenna (often referred to as an “omni”) is a very popular array design for base stations. It is comprised of quarter-wave coaxial sections with inner and outer conductors transposed at each junction.

A conceptual illustration is shown in figure 23. Although more complex than the illustration, this antenna array behaves like a series of vertical dipoles stacked one above the other. The more stacked sections, the greater the gain and the narrower the vertical beamwidth. A vertical-plane pattern for this type of antenna is shown in figure 24.

Variations in electrical design can produce a downward tilt of the vertical-plane pattern as shown in figure 25. This antenna often is enclosed in a fiberglass sheath, called a *radome*, and appears as a simple pole that can be mounted off the side or on top of a mast or tower.



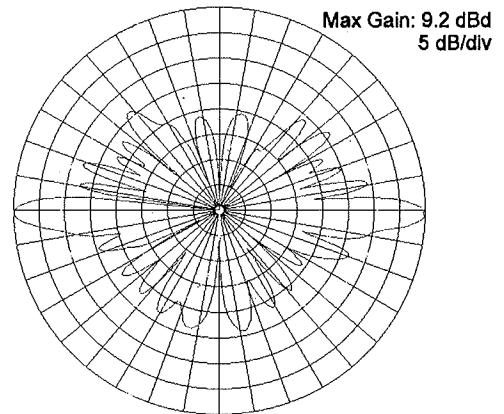
**Figure 23.** *A coaxial collinear array*

As with all antennas, the array is frequency-dependent. The gain, directivity, and radiation pattern are each a function of frequency. Some antennas will work well only for the design frequency, and their performance will degrade as the operating frequency is separated from the design frequency.

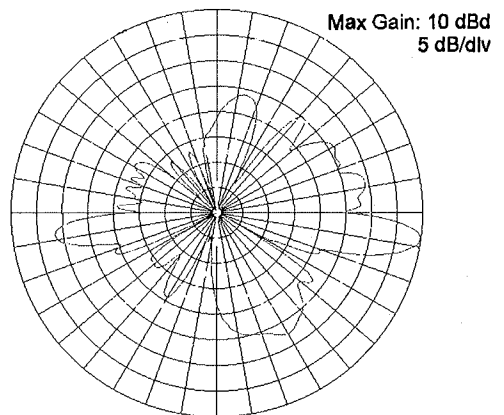
### 5.7 Unusual Antennas

There are many other antenna types. Most of these are beyond the scope of this report, but knowledge about some may be useful for LMR users.

While not as commonplace as wire or rod antennas, aperture antennas are by no means unusual. These antennas are implemented as an opening in a relatively large, conductive (metal) surface.

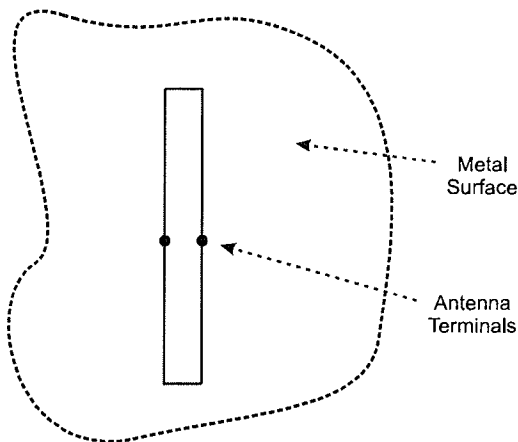


**Figure 24.** *A vertical-plane radiation pattern without "tilt"*



**Figure 25.** *A vertical-plane radiation pattern with 8° "tilt"*

The simplest aperture antenna is the slot antenna, which is equivalent to a dipole. As shown in figure 26, it is a long, narrow opening with terminals located at the middle of the long sides of the slot. This simple slot and more complex versions are well-suited to covert operations. They can be located on a vehicle surface and concealed behind a cover of thin insulating material. Slot antennas are common on aircraft and missiles.



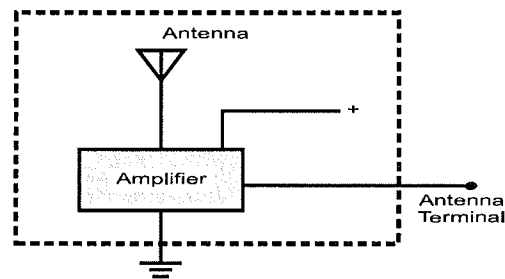
**Figure 26. A slot antenna**

Not so much antenna types as antenna features, broadband and multiband antennas are the result of design efforts to make an antenna perform well over a wide band of channels. There may be a trade-off in making an antenna broadband, such as a reduction in gain or an increase in physical size. The usual design goals for this type of antenna are to make the gain and radiation pattern, as well as the terminal impedance, relatively constant over the frequency range of operation. The log-periodic array is an example of a broadband antenna.

Multiband antennas are designed to operate on several bands, for example, at both VHF high-band and UHF. These antennas often involve clever designs where one part of the antenna is active for one band, and another part for a different band. Again, there will be compromises. The antenna may have lower average gain or may be physically larger than an equivalent single-band antenna.

## 5.8 Active Antennas

An active antenna is one that contains some electronic circuitry that can amplify a received signal at the antenna and thus avoid interference that may enter the system at the transmission line. Figure 27 shows this concept. The antenna “element” is connected to the input of an amplifier. The output terminals of the amplifier are the antenna terminals for this active antenna. The antenna element and the amplifier are included in the “active antenna,” shown as a dashed box in the figure.



**Figure 27. A simple active antenna**

Another purpose of an active antenna is to transform an unusual antenna terminal impedance to a constant value that matches the characteristic impedance of the transmission line. This function is useful for some antenna designs in which a specific pattern feature is desired, but cannot be achieved without causing the antenna to have an unusual terminal impedance. An active antenna is nonreciprocal and cannot be used for transmitting.

## 5.9 Diversity Antennas

Diversity is a technique that improves reception of radio waves by taking advantage of the fact that signals that vary with time (*e.g.*, fading) are not the same at separated locations. In other words, the fading of a

signal may be quite different for two locations separated by as little as one wavelength. To take advantage of this, two antennas, separated by some distance, are used to receive the same signal. Of the two signals, the one with the highest signal level, at any given time, is automatically sent to the receiver. This process is only useful for reception. The electronics required for this kind of signal processing are sometimes part of the antenna system.

Adaptive antennas extend the concept of diversity another step further. These antennas usually incorporate more than just two elements (*i.e.*, individual antennas) in the array. An adaptive antenna can modify its radiation pattern (within limits) in real time to ensure that the main lobe points in the direction of greatest signal level. Alternatively (or, possibly, simultaneously), the same technique can be used to point a null in the direction of an unwanted, interfering signal.

## 6. TRANSMISSION LINES AND OTHER COMPONENTS

Transmission lines are conduits for transporting RF signals (and the energy contained in those signals) between elements of a communications system (fig. 1).

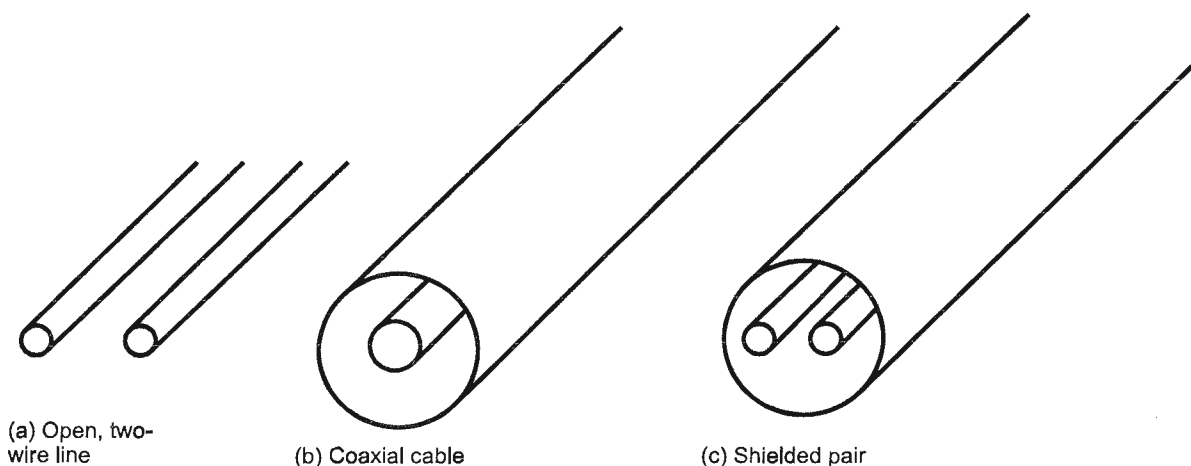
Transmission lines are not simply conductors that carry electrical current like the power cord for an electrical appliance does. Transmission line principles, derived from electromagnetic theory, must be used when the line exceeds a few tenths of a wavelength.

On a transmission line, not only do currents flow within and on the surfaces of the conductors, but traveling electromagnetic fields are also “guided” by the conductors. Therefore, the geometry of the transmission line is fundamental to its electrical characteristics.

### 6.1 Transmission Line Types

Figure 28 shows the arrangement of conductors for several common types of transmission lines. The open, two-wire line, shown in figure 28(a), is easy to construct and its characteristics are readily adjusted by changing the diameter and spacing of the wires. However, the electromagnetic field created between and around the conductor extends far beyond the line, so radiation losses become excessive at high frequencies. For this reason, it is only practical for use below several hundred megahertz. This line is also called “ribbon,” “parallel,” or “twin-lead” cable and was used extensively, from the 1950s to the 1970s, to connect a home television set to its antenna.

The most common transmission line in use today is *coaxial cable*, which gets its name from the coaxial arrangement of its conductors, as shown in figure 28(b). The center conductor may be held in position with periodically-spaced dielectric (insulating) beads or with a continuous, solid

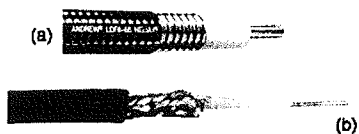


*Figure 28. Common types of transmission lines*

dielectric that fills the space between the conductors. The outer conductor can be either solid or braided; the latter making a more flexible cable. The coaxial cable is effectively self-shielded and has no external fields. For this reason, its losses are low and it is useful for frequencies as high as 3 GHz. Since the outer conductor of a coaxial line is usually grounded, it is not a balanced line. In other words, both conductors are not equally isolated from ground as is the case with the open, two-wire line. This distinction is an important factor at the connection to the antenna. A *balun* (see sec. 6.2) may be needed at that point to “match” the unbalanced line to an antenna.

A very wide variety of coaxial cable (often called “coax”) is available to meet different requirements. Generally available in only two values of characteristic impedance—50 Ω and 75 Ω—coaxial cable is made in many sizes of various materials.

Figure 29 shows two common coax types. The cable shown in figure 29(a) has a semi-rigid, helical outer conductor, so it is less flexible. This cable is commonly used for base-station applications. The cable shown in figure 29(b) has a braided outer conductor. This type of cable is commonly used in mobile applications and for less-demanding base-station applications.



**Figure 29. Coaxial cables commonly used for LMR — (a) base-station applications and (b) mobile applications**

Coaxial cable is described by nomenclature derived from military standards [15]. The “JAN type” or “RG-” number assigned to a coaxial cable defines specific values for a wide range of physical and electrical characteristics. Selected characteristics for a few of the several hundred types of cables are given in table 1. Not shown in this table are other physical and electrical characteristics such as weight, tensile strength, materials used for the dielectric and sheath, maximum voltage, and attenuation.

There are many other transmission line geometries. The *shielded pair*, shown in figure 28(c), is not uncommon. It offers the fully shielded characteristic of a coaxial line and the balanced nature of a two-wire, parallel line.

## 6.2 Baluns

Since the outer conductor of a coaxial line is grounded, it is not a balanced line. In other words, the voltage potential difference between the inner conductor and ground is different from the voltage potential difference between the outer conductor and ground. This distinction is an important factor at the connection to the antenna. Antennas such as dipoles are balanced. A *balun* will be needed at the antenna terminals to connect the unbalanced coaxial transmission line to the antenna.

A balun is a device for transforming a load on an unbalanced transmission line (coaxial) or system to a balanced line or system. The name *balun* is a contraction of the terms *balanced* and *unbalanced*.

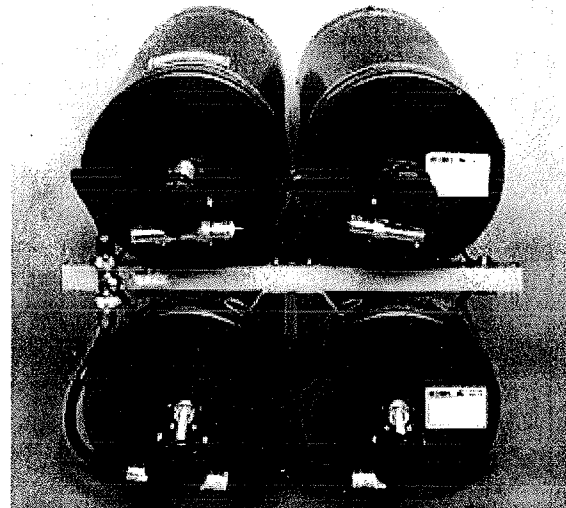


*Table 1. Characteristics of selected coaxial cable*

Type	Impedance	Inner Conductor	Outer Conductor	Diameter	Max. Power	Notes
RG-58/U	50 $\Omega$	19×0.0071 in (19×0.018 cm) stranded (tinned copper)	braid (tinned copper)	0.195 in (0.49 cm)	200 W	small, flexible, low loss
RG-55/U	50 $\Omega$	0.032 in (0.08 cm) solid (silvered copper)	double braid (silvered copper)	0.206 in (0.52 cm)	200 W	small, flexible, low loss
RG-11/U	75 $\Omega$	7× #26 AWG (tinned copper)	braid (copper)	0.412 in (1.05 cm)	750 W	medium sized, flexible

### 6.3 Duplexers

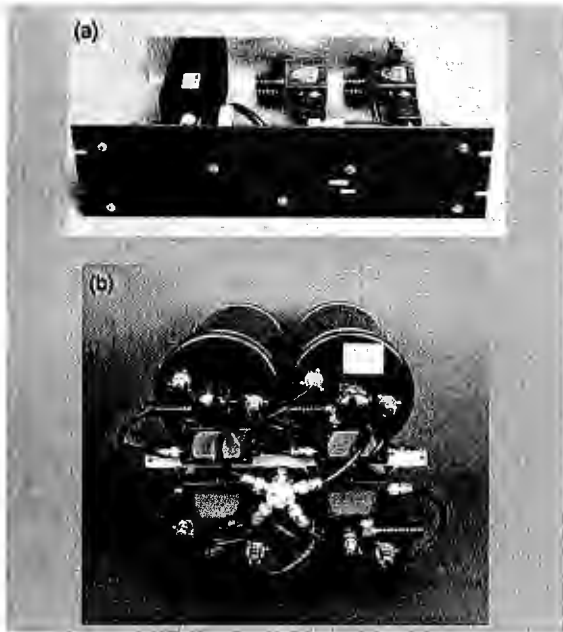
In order for transmitters and receivers to share a single antenna, a *duplexer* must be used. The duplexer acts as two parallel, frequency selective filters, directing transmitted signals to the antenna, preventing those signals from reaching and overloading collocated receivers, and routing all of the received signals from the antenna to the receivers. Duplexers used in the VHF and UHF bands are typically constructed from mechanically tunable, highly selective cavity filters, as depicted in figure 30.



*Figure 30. A VHF duplexer*

## 6.4 Combiners

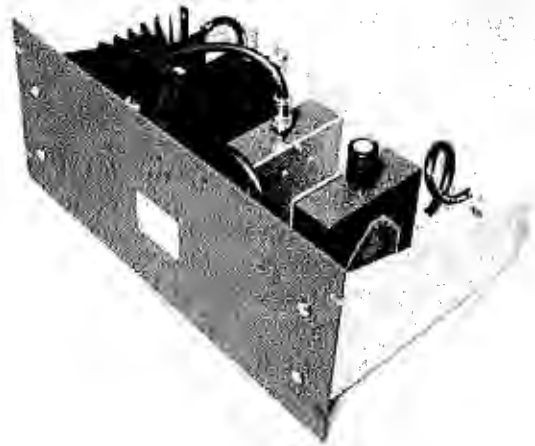
In order to combine more than one transmitter onto one antenna system, *combiners* are used. Two typical configurations, shown in figure 31, use either *hybrid combiners* (commonly called *hybrids*), or mechanically tuned, highly selective *cavity combiners* that use cavity filters quite similar to those used in duplexers. Depending on a number of factors, such as how close in frequency the transmitters are to one another and how many transmitters must be combined, one approach will offer superior performance over the others. Vendors and manufacturers should be able to explain why they selected one combining method as opposed to the other for their design.



**Figure 31. Typical types of combiners — (a) hybrid combiner and (b) cavity combiner**

## 6.5 Intermodulation Suppression

Cavities and hybrids will likely not provide sufficient attenuation to RF signals (from other collocated transmitters) that could cause intermodulation interference. *Isolators* are used to provide additional protection against intermodulation interference. These devices provide very low attenuation to signals passing through them in one direction, while providing a high degree of attenuation to signals passing through them in the other direction. They are the principal components of *intermodulation suppression devices* (fig. 32).



**Figure 32. Intermodulation suppression device**

## 6.6 Multicouplers

Just as multiple transmitters can share an antenna, so can multiple receivers. Inbound RF signals are “split” and routed to the appropriate receivers. Because RF splitters attenuate the signals passed through them, a preamplifier precedes the splitter. Its amplifier gain is carefully adjusted to compensate for the splitter loss, but is not set too high, as the resultant intermodulation

interference signals would be detrimental to proper receiver performance. These preamplifiers and signal splitters are combined into a single assembly known as a *multicoupler* (fig. 33).



*Figure 33. A multicoupler*



## 7. RADIO WAVE PROPAGATION

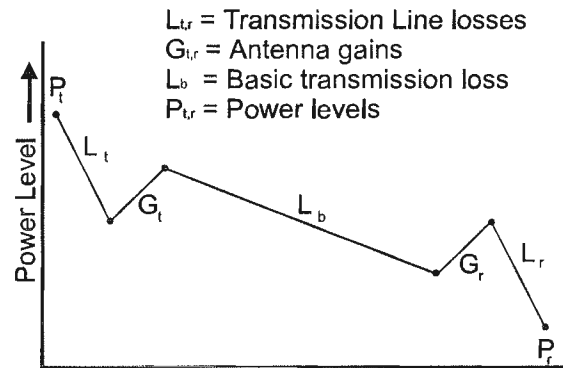
The propagation of radio waves through space (and the atmosphere) is the essential phenomenon exploited by a radio communications system. As described earlier (sec. 3), this phenomenon has been studied extensively using theoretical and empirical methods. The simplest mode of propagation occurs between two point-sources in free space—the ideal situation.

Radio-wave propagation, in realistic situations, is affected by reflections from the earth, scattering by particles, diffraction over hills, and bending due to atmospheric refractivity. The study of propagation has led to models that can be used to predict the field strength (and/or power density) expected at a specific receiver location of a radio wave radiated from a distant transmitter location.

### 7.1 Transmission Loss and the Power Budget

The concept of *transmission loss* is used to quantify the effects of radio wave propagation in the analysis and engineering of radio communications systems. It is defined as the ratio of power delivered to the terminals of the transmitter antenna to the power available at the terminals of the receiver antenna. The transmitter and receiver antenna gains are implicitly included in this definition. In practice, this is not useful, so the concept of *basic transmission loss* is used. It does not include the antenna gains. Basic transmission loss  $L_b$  is defined as the ratio of the power delivered to a lossless isotropic antenna at the transmit location to the power available at the terminals of a lossless isotropic antenna at the receive location.

With this definition of basic transmission loss, a power budget can be developed. This is shown graphically in figure 34, which shows the effects of the major elements in the radio link.



**Figure 34. Gains and losses as described in the power-budget equation**

It begins with the power output of the transmitter  $P_t$  in decibels relative to some reference (if referenced to 1 W, this is expressed as dBW). The loss, in decibels, due to the transmitter transmission line  $L_t$  is subtracted from  $P_t$ . Then the transmitter antenna gain  $G_t$  is added. The basic transmission loss  $L_b$  is subtracted. Then at the receive end of the link, the receive gain  $G_r$  is added; and the receiver transmission line loss  $L_r$  is subtracted to arrive at the power delivered to the receiver input  $P_r$ .

Expressed as an equation, the power budget is

$$P_r = P_t - L_t + G_t - L_b + G_r - L_r. \quad (11)$$

The received power is in the same units as those used to express the transmitted power.

For example, a transmit power of 25 W, expressed in decibels, would be  $10 \log_{10} (25)$  or 14 dBW. The result is that the power available at the receiver input  $P_r$ , is expressed in the same units (dBW in this example).

## 7.2 Free-Space Basic Transmission Loss

The transmission loss between two lossless isotropic antennas in free space<sup>4</sup> is a hypothetical, but very useful, propagation model. It can be used as a “first estimate” in radio link design or a “best case” value for transmission loss over any real, terrestrial path.

The free-space basic transmission loss  $L_{bf}$  is very easy to calculate. Since the transmit antenna is considered to be a lossless isotrope (and the transmission line is considered to be lossless as well), all of the transmitter power is radiated equally in all directions. At a distance  $d$  selected to be much greater than the wavelength  $\lambda$ , the radiated power density (expressed in watts per square meter) is simply the transmitter power divided by the area of a sphere with radius  $d$ , as follows:

$$p = \frac{P_t}{4\pi d^2} \quad (12)$$

Now, looking at the receive side of the link, the signal power output  $P_r$ , in watts, of a lossless, isotropic receive antenna can be computed using equation 9. It is the product of that antenna’s effective area  $A_e$  times the power density  $p$  of the incident wave as follows,

$$P_r = A_e p \quad (13)$$

Using equation 10, the effective area, in square meters, of a lossless isotropic antenna ( $g = 1$ ) is

$$A_e = \frac{\lambda^2}{4\pi} \quad (14)$$

Substituting equations 12 and 14 into equation 13, the result is

$$P_r = \frac{\lambda^2}{4\pi} \cdot \frac{P_t}{4\pi d^2} \quad (15)$$

Rearranging this equation to form the definition of  $L_{bf}$  as the ratio of  $P_t$  to  $P_r$  (see sec. 7.1),

$$L_{bf} = \frac{P_t}{P_r} = \left( \frac{4\pi d}{\lambda} \right)^2 \quad \text{dB} \quad (16)$$

In decibels, this equation becomes,

$$L_{bf} = 10 \log_{10} \left( \frac{4\pi d}{\lambda} \right)^2 \quad \text{dB} \quad (17)$$

By converting wavelength to frequency using equation 1 and taking the logarithm of the terms in parentheses, a very practical version of this equation results.

$$L_{bf} = 20 \log_{10} d - 20 \log_{10} f - 32.45 \quad \text{dB} \quad (18)$$

where  $d$  is expressed in kilometers and  $f$  is expressed in megahertz.

This last equation is the *propagation model for free-space, basic transmission loss*. It predicts a value of basic transmission loss under a set of assumptions (*i.e.*, lossless

<sup>4</sup> Free space is a theoretical concept of space devoid of all matter. In practice, free space implies remoteness from material objects that could influence the propagation of electromagnetic waves.

isotropic antennas located in free space). As an example of how to use this model and the power-budget equation, consider a radio link 10 km long operating at 400 MHz. For this link, assume that the transmit antenna has a gain of 10 dB, the receive antenna has a gain of 3 dB, and that both transmit and receive transmission line losses are 1 dB. The transmitter power is assumed to be 20 W (13 dBW).

The basic free-space transmission loss is first computed as

$$\begin{aligned}
 L_{bf} &= 20 \log_{10} (10) \\
 &= 20 \log_{10} (400) \quad 32.45 \\
 &= 20 \quad 52.04 \quad 32.45 \quad (19) \\
 &= 104.49 \text{ dB} .
 \end{aligned}$$

Then, using the power budget equation 11, we find that

$$\begin{aligned}
 P_r &= 13 \text{ dBW} \quad 1 \text{ dB} \quad 10 \text{ dB} \\
 &= 104.49 \text{ dB} \quad 3 \text{ dB} \quad 1 \text{ dB} \quad (20) \\
 &= 80.49 \text{ dBW} \\
 &= 50.49 \text{ dBm} .
 \end{aligned}$$

This result shows a receive power of about one one-hundredth of a microwatt, or about nine orders of magnitude less than the transmit power. At this level, it is a strong receive signal. An actual radio link, over varied terrain, may have a larger measured transmission loss by 5 dB to 20 dB. The transmission loss over a realistic link will also vary with time.

### 7.3 Terrestrial Propagation

A variety of natural and man-made objects and phenomena will affect the radio signal as it propagates from the transmitter to the

receiver. Some of these effects are described in the following subsections. Although it is important for the reader to be familiar with these concepts, it is unnecessary for the reader to determine the exact extent that each effect affects the antenna system. Several computer models are available that provide relatively accurate propagation predictions. Such models are described in section 7.4.

#### 7.3.1 Effects of Earth

The Earth acts as a reflecting surface for those waves that radiate from an antenna at angles lower than the horizon. Waves that strike the Earth are reflected along the same direction of travel, at the same angle as the angle of incidence. The illustration in figure 35 shows how waves propagate over both direct and reflected paths to reach a distant location.

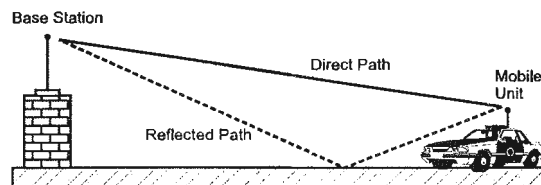


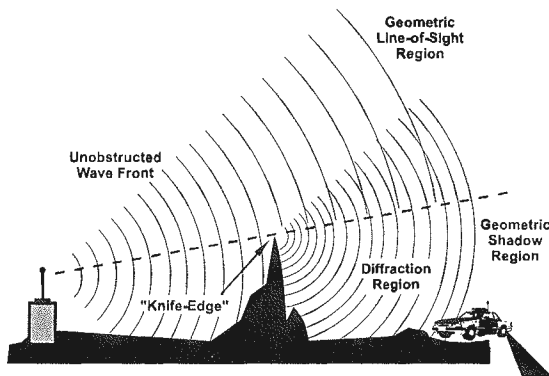
Figure 35. A propagation path illustrating direct and reflected rays

The reflected waves combine with the direct waves with a variety of results (*i.e.*, they enhance or cancel each other to some degree). Some of the factors that cause this variety are the height of the antenna, the orientation of the antenna, the length of the antenna, and the characteristics of the ground reflecting the wave. As part of the wave strikes the ground and reflects forward, that part of the wave will take a slightly longer time to arrive at the receiver. At some

reflection angles, the direct wave and reflected wave will arrive almost in phase (*i.e.*, the amplitude of each wave will be at its maximum at the same time). When this happens, the power of the received wave is approximately twice that of the direct wave. At some angles, the reflected wave is exactly out of phase with the direct wave, essentially nullifying the wave. This is known as *cancellation*. At other angles, the resultant wave will be somewhere in between.

As radio waves strike a radio-opaque object, some of the signal will be reflected in directions away from the receiver. Some of the signal will be absorbed by the object.

The waves that strike the edges of the object, however, will be diffracted into the shadow of the object. To a receiver positioned within such a shadow, the object's edge will seem like another source. This can cause interference with the original signal or provide signals to areas that should not receive them. This phenomenon is shown in figure 36.



**Figure 36.** *An example of diffraction*

### 7.3.2 Coverage

The area over which the signal can be detected is called the *coverage* area for the antenna. The coverage area is often displayed as contours on a two-dimensional drawing or on a map.

A radiation pattern is not the same thing as a coverage area, although they are related. The radiation pattern for an antenna is a gain factor, in every direction away from the antenna, and is a function *only* of the antenna design.

The coverage area for an antenna is the area over which a signal, of predetermined strength (or greater), can be received. The coverage area is a function of the transmit power, antenna gain, radiation pattern, noise, and propagation factors related to the environment.

### 7.3.3 Noise and Interference

All things emit some radiation at all frequencies. In most cases, for most objects, the level of this continuous radiation, at any given frequency, is small and of little concern. This radiation is called *noise*. The most common sources of noise for a radio receiver are:

- Atmospheric and galactic noise.
- Noise from the first amplifier in the receiver.
- Man-made noise (motors, fluorescent lights, *etc.*).

When a radio receiver is far enough away from a transmitter (or in an antenna pattern *null* where reception is difficult), the strength of the transmitted signal is low enough that ambient radiation noise from other objects or transmissions in the area can obscure the



desired signal. When the strength of a received signal is less than the strength of the ambient noise for that frequency, the signal is said to be “lost in the noise.”

Ambient noise for a specific transmission is usually measured at the transmission frequency.

*Interference* is the term for unwanted signals, generated from other transmitters, that interfere with clear reception of the intended signal. Interference is not technically included under the definition of noise, although slang usage of the term “noise” includes any unwanted signals.

#### 7.3.4 Terrestrial Propagation Models

Radio-wave propagation in the terrestrial environment is an enigmatic phenomenon whose properties are difficult to predict. This is particularly true for LMR applications where terrain features (hills, trees, buildings, *etc.*) and the ever-changing atmosphere provide scattering, reflection, refraction, and diffraction obstacles with dimensions of the same order of magnitude as the wavelengths.

Some models are general and some are more specialized. An example of the former is a model that would predict radio coverage areas in “generic” urban areas or “generic” rural areas, without regard to specific terrain profiles. One of these generalized models is the Okumura-Hata model [16]. Models such as the Okumura-Hata model are based on extensive collections of empirical measurements.

Other more sophisticated computer programs predict transmission loss, and account for the time and location variability of that loss, over defined terrain profiles.

These terrain profiles are compiled from terrain-elevation data tabulated by agencies such as the Defense Mapping Agency and the U.S. Geological Survey. One such computer program, written and maintained by the U.S. Department of Commerce’s Institute for Telecommunication Sciences (ITS), is the Communication Systems Performance Model (CSPM) [17]. This program is based on the ITS Irregular Terrain Model [18].

Usually, manufacturers and vendors of radio and antenna systems and components have computer programs similar to CSPM to assist customers in defining radio-coverage areas. Private-industry radio-engineering consultants also have computer programs like CSPM to perform radio-coverage analysis for customers. Alternatively, agencies can access CSPM on a fee-reimbursable basis through the ITS Internet site<sup>5</sup>.

#### 7.4 Co-Site Analysis

*Intermodulation (IM) interference* (*i.e.*, “intermod”) and *receiver desensitization* are detrimental to the performance of co-sited repeaters and base stations. There are several different ways intermod *interference* can be generated. One way is when sufficiently large power from a transmitter enters into the final output power stage of another transmitter. This may occur when, for example, the transmitters are connected to a combiner junction and the combining cavity/isolators of the affected transmitter do not provide sufficient rejection between transmitters.

---

<sup>5</sup> <http://flattop.its.blrdoc.gov/tas.html>.

For additional information, contact the Institute for Telecommunication Sciences at 325 Broadway (ITS.E), Boulder, Colorado 80305-3328, Telephone 303-497-5301.

Intermodulation may also arise when several transmitting antennas are located in very close proximity to each other, such as multiple omni-directional antennas on a building rooftop. In these situations, mixing of signals may occur between the offending transmitter(s) and the desired signal, thereby generating new signals in the victim transmitter, at frequencies determined by the intermod products. These intermod signals will be emitted by the victim transmitter.

Other ways that intermod can occur are by the mixing of signals from two or more transmitters in the front-end of a receiver. Off-frequency signals strong enough to overcome the suppression of bandpass cavities and preselector filters may saturate the nonlinear first or second intermediate frequency (IF) mixers of the victim receiver, creating intermod products which adversely affect receiver performance.

External intermod can also be created in elements such as corroded antenna guy wires, anchor rods, and even chain link fences. As strong signals impinge upon these items, the corroded objects act as diodes and detect the signals, mix them, and passively reradiate the energy at the intermod product frequencies.

## 8. ANTENNA SYSTEM REQUIREMENTS AND DESIGN

The selection of a particular antenna system for use in a radio communications system is one of many interrelated decisions that must be made to meet the system-level requirements for a complete LMR system. Other system-level decisions include the number and locations of base and repeater stations, the antenna heights, and the transmitter powers.

Selecting the appropriate antennas for vehicular and hand-held units is a much simpler process than selecting the appropriate antennas for fixed stations. Although there are exceptions, the whip antenna is, essentially, the only practical antenna design for vehicular and hand-held radios. The most important aspect for vehicular antennas has to do with *where* it is mounted on the vehicle. The best location for vehicular antennas is in the middle of the roof. This is the highest point and presents the flattest and most symmetric ground plane to the antenna, both important factors to optimize communications range and performance. Vehicular obstructions, such as the light bar on law enforcement vehicles, will, however, distort the radiation pattern and/or alter the antenna's terminal impedance slightly.

Bumper mount installations for low-band VHF, for example, may be selected based more on the antenna installation structural rigidity requirements than on ground plane symmetry, radiation pattern distortion, and other RF performance parameters.

Choices for hand-held radio antennas are, in practice, limited to short whip antennas. These antennas are physically very short, are

typically inductively or resistively loaded (to simulate, electrically, a longer antenna and/or to provide a better impedance match). These features and attributes are accomplished at the cost of decreased antenna gain.

Selecting appropriate antennas for fixed stations is more critical than selecting the antennas for mobile and hand-held units. This is because antennas for fixed stations must be chosen to adequately receive signals from the least-capable mobile/hand-held units (those with low transmitter power, low antenna gain, low antenna height, *etc.*).

When designing a radio system for LMR use, a systematic development plan must be created and followed:

- Define System Requirements.
- Design System.
- Select Appropriate Components.
- Procure and Install Components.
- Perform Routine Maintenance.

Each of these steps is dependent on the previous step in the chain.

### 8.1 Define System Requirements

The design and deployment of an LMR communications system, or the upgrade or expansion of an existing system, generally begins with some knowledge of what geographic regions need to be "covered" by the radio communications system. This is a fundamental requirement that is determined by the nature of an agency's jurisdiction, where population and transportation routes are located, and so on. These requirements must be developed by the agency itself.

Several other system-level requirements can also be developed by the agency before obtaining the services of a radio system vendor or consultant. Larger law enforcement agencies will have a communications department that will perform these services. The number of mobile and handheld units, for example, is usually determined by the number of users that must be supported.

Next, some decisions must be made regarding how many channels will be needed. For example, one or more channels may be needed for dispatch functions. Additional channels may be needed for mobile-to-mobile communications. Other channels that might be needed could include:

- A local command channel for operations at an event site.
- A channel to interoperate with other agencies in mutual-aid situations.
- A channel dedicated to tactical forces.
- Other channels to support the operational and administrative activities of the agency.

Other aspects that may affect system design include:

- The typical length of messages for the various channels and talk groups.
- Maximum level of activity for the dispatch channel.
- The nature of operations that use the local command channel.
- Geographic coverage requirements.
- The specific level of performance (*i.e.*, speech intelligibility and/or data-transmission throughput) required.

Having a working knowledge of these system-level requirements will help ensure

efficiency in the system design process that follows, and will help ensure the reliable performance of the system when it is fully deployed.

Begin by developing some initial system requirements. Consider, for example, the following:

- At what frequencies will you be transmitting? Lower frequencies require larger antennas. Higher frequencies have more limited range. A wide range of frequencies will require multiple antennas, multiband antennas, or broadband antennas.
- What is the maximum distance over which your users must communicate? Systems to support distant itinerant users will require a combination of higher-power transmitters and antennas with greater gain.
- What is your coverage area? Required antenna radiation patterns will be dictated by the location of the fixed site relative to the required coverage area.
- Are there other nearby radio systems operating in neighboring frequency bands or on the same or adjacent frequency channels? Your system might cause interference to these other users, or conversely, these systems might cause interference to your new system.
- What physical limits are there on your design? Is there sufficient property to construct a site, or is there sufficient space on shared antenna towers for your system? Will building code and zoning ordinances impact the construction of your system?
- What about standby/back-up systems at this site or at another antenna site?

- What level of speech intelligibility is required? How much noise and distortion can be tolerated? For data transmissions, what data-throughput rates are required (how large is the data file and how much time is available for transmission)?

## 8.2 Design System

The decisions that must be made during the design of a new system or the expansion of an existing system include:

- The number of base and repeater stations and their locations.
- Some initial choices of antennas and antenna heights for those fixed sites.

The design process will require the identification of:

- The availability of channels in the various LMR frequency bands.
- Potential/alternative base and repeater station locations.
- The potential for sharing fixed-station infrastructure among multiple agencies.
- The estimated cost of the system.

## 8.3 Select Appropriate Components

Once the system performance and system design requirements have been ascertained, the antenna characteristics that must be considered are the antenna system gain and radiation pattern. The process of identifying the needed gain and pattern is usually an iterative one. The process might proceed as follows:

First, coverage predictions are made. Values for transmitter power, operating frequency, antenna system losses, antenna gain, antenna

height, antenna pattern, and minimum acceptable received signal strength for some specified level of speech intelligibility are required in order to make these coverage predictions.

Intermodulation interference analysis must also be considered during the design phase, particularly where multiple transmitters, receivers, and/or repeaters are collocated. Antenna system manufacturers and vendors can assist agencies in predicting the likelihood of IM interference or receiver desensitization, either caused by or inflicted upon the proposed new system. To mitigate IM interference at repeater and base station antenna sites, their designs will include isolators, cavity filters, duplexers, combiners, and multicouplers. The number of collocated systems and the frequency separations between them also influences the choice of combiner and duplexer components.

System design and component selection continue by interactively trying different antenna gains, patterns, and heights at each potential site location until the desired coverage is attained. Then, antenna system installation at each fixed site needs to be considered. Points to consider include:

- Antenna tower height—Will the proposed antenna tower conform to local building codes and zoning ordinances?
- Environmental considerations—Will the antenna system and supporting structure survive expected wind loading, ice loading, and other anticipated environmental performance factors? EIA/TIA Standard 329-B [19], EIA/TIA Standard 329-B(1) [20], NIJ Standard-0204.02 [21], and

NIJ Standard-0205.02 [22] all provide guidance regarding the minimum environmental, as well as RF, performance criteria required of all antennas used in the law enforcement and corrections arenas.

- Security—Is the site secure against unauthorized intrusions, yet accessible to maintenance personnel?
- Accessibility—Could inclement weather (*i.e.*, deep snow drifts, washed-out dirt access roads) prevent maintenance personnel from reaching the site?
- Co-site analysis and IM interference—Will retrofitting new systems into existing infrastructures introduce adjacent-channel interference, co-channel interference, IM interference, or receiver desensitization upon other existing systems or upon the new system? Will other nearby users and systems detrimentally affect the performance of the new system because of these problems? How will the vendor mitigate predicted interference problems? Does the vendor have a plan to mitigate unforeseen interference problems?
- Power source—Is commercial electrical power available? Will solar/battery power be required as primary/backup power?
- Wireline/wireless link—Is telephone service available? Is fiber optics service available? Will microwave radio be required?

## 9. INSTALLATION, MAINTENANCE, AND SAFETY

### 9.1 Vehicular Antenna Systems

The procurement and installation of vehicular antenna systems are relatively straightforward. If the design requirements have been well thought out and adequately described in the procurement documents, a competitive procurement will deliver an acceptable product.

When installing a vehicular antenna system, care must be given to routing the coaxial cable between the radio and antenna. The cable should not be exposed to the elements (wind, road salt and sand, rain, intense sunlight, extreme heat, *etc.*) nor should it be in a location where it could be severed or pinched (by opening and closing vehicle doors, for example) or where a vehicle's occupants might become entangled with it. One preferred routing for a roof-mounted antenna might be between the roof and interior headliner of the vehicle, down through a windshield pillar, and behind the dashboard panel to the radio. Other equipment, such as *duplexers* (to combine multiple radios operating in different frequency bands onto one multiband antenna), should likewise be installed in locations not readily accessible to vehicle occupants. For example, they should be installed under seats or in trunks where they are "out of the way," yet reasonably accessible to maintenance personnel.

RF cable connections should be torqued to the proper force recommended for the particular connectors used, and the outer grounded conductor of the antenna base mount must be RF-bonded to the metal of the roof or trunk deck. Trunk deck installations also require excellent RF

bonding from the trunk lid to the main vehicle body. One way to accomplish this is by using a short length of low-impedance copper grounding strap affixed to bare areas of (interior) sheet metal on the underside of the trunk deck and the main vehicle body, using noncorrosive bolts, star washers, and lock nuts. A poor ground connection will detrimentally affect antenna operation, resulting in erratic or unacceptable performance.

### 9.2 Fixed-Site Antenna Systems

Most new installations of fixed-repeater and base-station antenna systems will likely be performed by contracted installers or equipment suppliers. In many cases, retrofitting new or upgraded components into existing facilities will similarly be performed by contracted installers or equipment suppliers. Procuring agencies should, nevertheless, ensure that the installer observes sound installation practices. As with vehicular grounding, proper ground protection of fixed station antenna facilities is important.

#### 9.2.1 Fixed-Site Antenna System Grounding and Bonding Practices

An effective grounding system is necessary for every antenna tower. In addition to the protection a grounding system offers from lightning strikes, grounding also:

- Reduces the hazards of electrical shock resulting from ground/neutral power faults.
- Protects wiring and circuitry by limiting extraneous over-voltages.

- Facilitates rapid discharge of faulted power circuits.
- Reduces noise voltages.
- Provides a path to dissipate any stray RF current present inside the transmitter station; ungrounded RF currents can contribute to equipment malfunction, or create interference with other receivers.

### 9.2.2 Fixed-Station RF Bonding

RF bonding is another important aspect of fixed-station antenna systems. Simply connecting each element of a transmitter facility to a metal pipe stuck in the ground is barely adequate to act as a grounding system. The components of such a grounding system are not perfect conductors and each will have different, finite values for resistance. The resistance and physical design of the grounding system adds to the overall resistance and reactance of the antenna system and transmission line, causing the system to have different voltage potentials at different points within the system, inducing stray currents to flow between equipment chassis. These stray currents can affect internal circuits of the equipment and cause erratic operation and unpredictable behavior.

A bonding system ensures that all equipment grounding points are at the same electrical potential. A good dc and RF bonding system will use high-quality, low-impedance copper strap or braid and attach all equipment chassis to a low-impedance copper bus strap installed on the walls throughout the station facilities. The copper bus leaves the station and is attached to the Earth using a copper ground rod approximately 3 m long. The point of egress for the facility ground should be at the same entry point as RF cable, telephone, and power connections.

### 9.3 Lightning Protection

The National Fire Protection Association (NFPA) publishes a guideline related to lightning protection [23]. This guideline details many additional practices for protecting radio equipment from lightning strikes.

Metal antennas and towers should be connected to the building's lightning protection system. Wires and metallic elements comprising an antenna tower's lightning protection system should be electrically attached to the Earth. Towers and guy wires anchored to concrete forms in the ground are often assumed to be well grounded, but concrete is a poor electrical conductor. Tower legs should be electrically attached to the Earth with a copper ground stake approximately 3 m long. Lightning-ground connecting leads connecting the tower to the ground stake should be at least AWG #10 copper, AWG #8 aluminum, or 3/4 in copper braid.

The transmission lines must be protected by lightning arresters, protectors, and discharge units. Arresters can be placed at both ends of the transmission line for added protection.

### 9.4 During Installation

Be sure the installer knows exactly where on the vehicle or on the antenna tower the antenna components are to be installed. Make sure they are installed in the correct orientation and positioned correctly.

Make sure that the ends of the transmission line cable have been prepared properly before affixing RF connectors to the transmission line. Make sure that the RF connectors are properly installed on the transmission line. Loose connector



assemblies will result in poor ground connections between the outer connector shell and the outer shield of the transmission line. Make sure that the center pin is securely affixed to the center conductor of the coaxial transmission line and that the center pin's depth, relative to the connector shell, is maintained at the correct distance, or an impedance mismatch or connector damage will result. Make sure that the antenna and transmission line connectors will mate properly before connection to other equipment is attempted. Connectors can be easily misaligned or over- or under-torqued, resulting in degraded or erratic overall RF performance. Make sure that the transmission line has not been damaged in any way, such as crushed, severed, or pinched.

Check the VSWR as soon as possible after installation, and, if possible, before the installer leaves the job site. In addition to VSWR measurements, time-domain reflectometry (TDR), line-fault measurements are helpful. Use a portable transmitting unit if the radio transmitter is not yet installed. Record the VSWR values and TDR data for future reference.

Measure and record the ambient noise power levels for future reference.

If possible, the installer should conduct "over-the-air" RF power sensitivity measurements immediately after installation, and document the test configuration and measurement results for future reference. For example, a portable antenna mast, 7 m to 10 m high, could be placed at a geological survey marker that has unobstructed, clear, visual line-of-sight to the repeater or base station-antenna tower. A portable transmitter could serve as the signal source. A similar

method could be used to measure the power received by a portable radio service monitor (such as an IFR1500 or Motorola R-2670) located at the survey-marker point.

Make a physical inspection of the installation. Be sure all connectors and transmission lines are secured properly.

## **9.5 Perform Routine Maintenance**

After a vehicular or repeater/base-station antenna system has been installed, the system will require periodic maintenance to ensure optimum performance.

Agencies should practice three tiers of maintenance. The first is performed by the radio operators and consists of simple, "common-sense" inspection of the equipment. The second level of maintenance is performed by site technicians and requires the use of land mobile radio test equipment. The third level of maintenance is performed by factory-authorized technicians.

### **9.5.1 Local Inspection**

Radio operators themselves can perform a wide variety of simple aural and visual inspections of their radio equipment and antennas. For instance:

- Isolated problems noted with reception or transmission in the field. Direct comparison between two radios ("I cannot hear the base station when I am in this location." "Oh, really? I can hear the base station okay.") gives an excellent indication of a problem with a subscriber unit.
- Loose or missing connectors—Over time, temperature variations, shock, vibration, exposure to the elements, and handling can cause connections

and connector flanges to become loose or missing altogether. Rubber O-ring grommet seals may deteriorate, allowing moisture to penetrate into connectors or the transmission line, altering their performance.

- Cracked or broken whip antenna base-loading coils—Cracks in the plastic housing of vehicular antenna base-loading coils can permit moisture and corrosive materials to penetrate into the loading coil, altering the antenna's electrical performance. Weathering of rubber grommet O-ring seals (where the loading coil is affixed to the roof or trunk deck of the vehicle) may similarly permit moisture and corrosive materials to penetrate into the connector between the loading coil and its attachment to the coaxial cable connector, altering the antenna's electrical performance.

### 9.5.2 Site Technician

The site technician will often have an array of RF test equipment at his or her disposal. For example, a communications service monitor can determine whether a radio is transmitting on the proper frequency, at the proper power level, with the proper frequency bandwidth. A VSWR meter gives an indication of how well RF energy is coupled from the radio system into the antenna. A time-domain reflectometer can determine where faults or other discontinuities exist along the length of a transmission line. Portable field strength meters can give an indication as to whether the antenna radiates electromagnetic energy as expected.

Vehicular antenna systems should be periodically checked according to an

established maintenance schedule, typically concurrent with the maintenance schedule of the mobile radio (perhaps once or twice per year). Performance values such as VSWR should be recorded, compared to the performance values measured just after installation, and tracked over time in order to assist in keeping the antenna system functioning at an optimal performance level.

The above statements apply equally to fixed-site repeaters and base stations.

Unfortunately, whereas problems with mobile and portable radio systems can be readily identified by direct performance comparison at the operator level, such is not necessarily the case for fixed sites. Because performance degradation at the fixed site affects all subscriber units equally, slowly occurring degradation in performance, caused by corrosion effects, weathering, *etc.*, may go unnoticed for years until catastrophic failure finally occurs. Therefore, regularly scheduled site visits to conduct maintenance performance inspections must be a part of the site technician's routine. Recording a time history of the RF performance, and comparing it to the RF performance measured immediately following the repeater or base-station installation, will be an invaluable maintenance aid.

Remote automated in-line diagnostic test equipment can also provide indications of needed maintenance. Several vendors of antenna system equipment, such as Bird Electronic Corp., Decibel Products, Sinclair Technologies, Telewave, and many others, manufacture remote in-line diagnostic measurement equipment. This equipment can report the health and status of a fixed repeater/base-station site's RF performance, up to the point where the radio wave is launched into space. For example, conditions

of low transmitter power and/or excessive VSWR, which might result from detuned combiner cavities or duplexers, failing radios, weathering of components, *etc.*, can be sensed by the automated diagnostic equipment. Alarm conditions can automatically be reported to a computer by preconfigured telephone dial-up to the centralized maintenance facility.

### 9.5.3 Factory-Authorized Technicians

If an antenna system or radio problem is too complicated for the local site technician to repair, the manufacturer should be contacted. Many large public safety organizations have service contracts with factory-authorized repair facilities to maintain, repair, and replace equipment. Even without a contract, contacting the manufacturer about specific problems is advised if the problems are beyond the abilities of the agency to repair.

### 9.5.4 Antenna Tower Safety

Working on antenna towers can be dangerous and potentially fatal. Serious personal injury and equipment damage can result from personnel falling, improperly installed equipment, and RF radiation exposure.

When maintenance personnel must work on antenna towers, safety equipment should be selected, used, and cared for as if their lives depend on it—because they do! A list of safety equipment should include:

- Safety belt.
- Safety glasses.
- Work boots with firm, nonslip soles and well-defined heels.
- Hard hat.

It is recommended that antenna tower installations have a personnel fall-arrester system. These systems permit maintenance personnel to attach their safety belts at ground level, and remain attached during tower ascent and descent, as well as while working at height. Antenna tower manufacturers, such as Rohn Tower, offer fall arrester systems, which comply with OSHA regulations.

In addition to personnel safety while ascending, working on, or descending antenna towers, maintenance personnel must be cognizant to the danger of RF electrical burns arising from direct contact with energized antenna elements, and to exposure to high levels of RF radiation. Industry standards have been developed that specify the levels of electromagnetic exposure to which personnel can be “safely” exposed [24]. Personnel working on transmitting antenna towers *must ensure* that *all* antennas that they are working on or near are disconnected from their associated transmitters, and that the transmitters are routed into dummy loads (to prevent damage to the transmitter final amplifier in the event of inadvertent transmissions), or that some sort of fail-safe mechanism for disconnecting power to those transmitters has been engaged.

Lastly, maintenance personnel should be alert to weather conditions. It is ill-advised to work on an antenna tower during an electrical storm or in high winds. Remember—safety first!

### 9.5.5 Vehicular Antenna Systems

The same precautions regarding RF exposure on antenna towers should be observed when operating or performing maintenance on

vehicular antenna systems. For example, personnel should not stand outside and next to their vehicle (where they do not have the benefit of RF shielding afforded by the vehicle's roof that they would have if they were inside the passenger compartment of the vehicle) while operating a 45 W (or greater) mobile radio transmitter, nor should they touch the antenna when transmitting.

#### **9.5.6 The Importance of Maintaining Your Radio System**

It must be stressed that regularly scheduled, periodic testing and preventive maintenance of the entire radio system is of paramount importance. Motor vehicles used by law enforcement and corrections, fire, emergency medical services, and other public-safety agencies are maintained by complying with strict maintenance schedules. Weapons are maintained by following regular preventive maintenance schedules of cleaning, lubrication, and inspection for worn or damaged parts. The same *must* hold true for all parts of a radio communications system—the lives of fire, emergency medical services, and law enforcement and corrections personnel may depend on it.

## 10. ANTENNA SYSTEM RESOURCES

This section describes some of the resources available to agencies to research information about and identify pertinent products, antenna systems and related components. There are many qualified and conscientious manufacturers and products available; only a few are cited herein in order to provide a sampling of what is available.

### 10.1 Internet Resources

As the World Wide Web (WWW or Web) has grown in recent years, many antenna manufacturers and suppliers have created Web pages devoted to their products.

Most Web-page authors will register their page with one or more of the major “search engines” on the Web. A search engine is a program that will use a search phrase provided by a user (usually a single word or simple phrase) to search hundreds of thousands of Web pages looking for occurrences of the phrase. The engine will then return a list of those Web pages that most closely match the search criteria (*i.e.*, those that contain the search phrase). A few search engines, such as Metacrawler (<http://www.metacrawler.com>) conduct searches by simultaneously querying more than one search engine.

### 10.2 Periodicals

Several periodicals are written for the land mobile radio industry. Most are free to “qualified” subscribers. These periodicals contain articles of technical interest related to land mobile radio, and advertisements for land mobile radio systems, components, and services. These periodicals publish, as special issues, buyers’ guides on an annual or

biannual basis. One such periodical that does this is *Mobile Radio Technology* (URL: <http://mrtmag.com>, telephone 1-913-341-1300). Another is APCO’s monthly *APCO Bulletin* (URL: <http://www.apcointl.org/bulletin/>, telephone 1-888-APCO-911). Public libraries may maintain subscriptions to this and other LMR-related periodicals, or they may be able to obtain issues under interlibrary loan agreements.

### 10.3 Manufacturers’ and Vendors’ Catalogs

Most antenna manufacturers and vendors distribute free catalogs that describe antennas, transmission lines, and related components that they offer for sale. Most catalogs provide useful technical information such as antenna patterns, operating frequencies, physical dimensions, and costs. Frequently, these catalogs will provide basic explanations about various aspects of antenna systems, such as collocated transmitter-combining techniques, intermodulation interference, transmission line theory, *etc.*

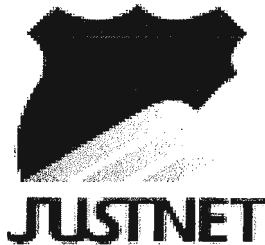
Many manufacturers have more than one product line, *e.g.*, antennas and duplexers. Information about manufacturers’ offerings can be identified and researched via the Internet or through the periodicals and buyers’ guides discussed in the previous two subsections.



## 11. PROFESSIONAL AND STANDARDS ORGANIZATIONS

The following subsections describe some of the various organizations that create and maintain antenna and radio standards or are otherwise of interest to the law enforcement or corrections officials interested in learning about antennas.

Most of the descriptive text in these subsections is taken directly from the Web site listed for each subsection and edited slightly for format or clarity.



1-800-248-2742

<http://www.nlectc.org/>

The Justice Technology Information Network (JUSTNET) was created in 1995 at the National Law Enforcement and Corrections Technology Center (NLECTC) National Center in Rockville, MD, and serves as a gateway to the products and services of the NLECTC System as well as other technology information and services of interest to the law enforcement and corrections communities. JUSTNET is a central element of the *National Institute of Justice* Office of Science and Technology's information collection and dissemination mission. Through JUSTNET, users have access to interactive bulletin boards on a variety of topics, a comprehensive database of law enforcement products and technologies, and NLECTC publications.



1-606-244-8182

<http://www.nastd.org>

The National Association of State Telecommunications Directors (NASTD) is a member-driven organization whose purpose is to advance and promote the effective use of telecommunications technology and services to improve the operation of State government.

NASTD members represent telecommunications professionals from the 50 States, the District of Columbia, the U.S. territories, and the private sector. State members are responsible for the provision and management of State government communications facilities and systems for State agencies and other public entities including hospitals, prisons, colleges, and universities. These members also play a strategic role in planning and shaping their States' telecommunications infrastructures and policies. Corporate members represent companies that provide telecommunications technology services and equipment to State government.

NASTD was founded in 1978 and has been an affiliate of the Council of State Governments (CSG) since 1980, with its headquarters in Lexington, KY.



*1-888-APCO-911*

*<http://www.apcointl.org/>*

The Association of Public-Safety Communications Officials International, Inc. (APCO International), is the world's oldest and largest not-for-profit professional organization dedicated to the enhancement of public safety communications.

With more than 13 000 members around the world, APCO International exists to serve the people who manage, operate, maintain, and supply the communications systems used to safeguard the lives and property of citizens everywhere.

APCO members come from many public safety organizations, including:

- Law Enforcement Agencies.
- Emergency Medical Services.
- Fire Departments.
- Public Safety Departments.
- Colleges and Universities.
- Military Units.
- Manufacturers.

APCO's mission is to:

- Foster the development and progress of the art of public safety communications by means of research, planning, training, and education.
- Promote cooperation between towns, cities, counties, States, and Federal public safety agencies in the area of communications.
- Represent its members before communications regulatory agencies and policy making bodies as may be appropriate.
- Through its efforts strive toward the end that the safety of human life, the protection of property, and the civic welfare are benefitted to the utmost degree.
- Aid and assist in the rapid and accurate collection, exchange, and dissemination of information relating to emergencies and other vital public safety functions.





1-212-642-4900

<http://web.ansi.org/>

The American National Standards Institute (ANSI) has served in its capacity as administrator and coordinator of the United States private sector voluntary standardization system for 80 years.

Founded in 1918 by five engineering societies and three government agencies, the Institute remains a private, nonprofit membership organization supported by a diverse constituency of private and public sector organizations.

Throughout its history, the ANSI Federation has maintained as its primary goal the enhancement of global competitiveness of U.S. business and the American quality of life by promoting and facilitating voluntary consensus standards and conformity assessment systems and promoting their integrity. The Institute represents the interests of its nearly 1 000 company, organization, government agency, institutional, and international members through its office in New York City, and its headquarters in Washington, DC.

ANSI does not develop American National Standards (ANSs); rather, it facilitates development by establishing consensus among qualified groups. The Institute ensures that its guiding principles—consensus, due process, and openness—are followed by the more than 175 distinct entities currently accredited under one of the Federation's three methods of accreditation (organization, committee, or canvass). In 1999 alone, the number of American National Standards increased by nearly 5.5 % to a new total of 14 650. ANSI-accredited developers are committed to supporting the development of national and, in many cases, international standards, addressing the critical trends of technological innovation, marketplace globalization, and regulatory reform.



*1-800-678-IEEE*

*<http://www.ieee.org/>*

The Institute of Electrical and Electronics Engineers (IEEE) is the world's largest technical professional society. Founded in 1884 by a handful of practitioners of the new electrical engineering discipline, today's Institute is comprised of more than 320 000 members who conduct and participate in its activities in 152 countries. The men and women of the IEEE are the technical and scientific professionals making the revolutionary engineering advances that are reshaping our world today.

The technical objectives of the IEEE focus on advancing the theory and practice of electrical, electronics, and computer engineering, and computer science. To realize these objectives, the IEEE sponsors technical conferences, symposia and local meetings worldwide; publishes nearly 25 % of the world's technical papers in electrical, electronics, and computer engineering; provides educational programs to keep its members' knowledge and expertise state-of-the-art. The purpose of all these activities is twofold: (1) to enhance the quality of life for all peoples through improved public awareness of the influences and applications of its technologies; and (2) to advance the standing of the engineering profession and its members.

The IEEE, through its members, provides leadership in areas ranging from aerospace, computers, and communications to biomedical technology, electric power, and consumer electronics. For the latest research and innovations in the many diverse fields of electrical and electronics engineering, industry and individuals look to the IEEE.



*1-703-907-7500*

*<http://www.eia.org/>*

For more than 70 years, the Electronics Industry Alliance (EIA) has been the primary trade organization representing the U.S. high technology community. EIA has created a host of activities to enhance the competitiveness of the American producer including such valuable services as technical standards development, market analysis, government relations, trade shows, and seminar programs.



1-703-907-7700

<http://www.tiaonline.org/>

The Telecommunications Industry Association (TIA) is a full-service national trade organization with membership of 900 large and small companies that provide communications and information technology products, materials, systems, distribution services, and professional services in the United States and around the world. The association's member companies manufacture or supply virtually all of the products used in the modern communications network. TIA represents the telecommunications industry with its subsidiary, the MultiMedia Telecommunications Association (MMTA), in conjunction with the Electronic Industries Alliance (EIA).

The TIA seeks to provide its members a forum for the examination of industry issues and information. The association serves as the voice of the manufacturers and suppliers of communications and information technology products on public policy and international issues affecting its membership. TIA supports and strives to further the growth of our economy, the progress of technology, and the betterment of humankind through improved communications. In 1924, a small group of suppliers to the independent telephone industry organized to plan an industry trade show. Later, that group became a committee of the United States Independent Telephone Association. In 1979, the groups split off as a separate affiliated association, the United States Telecommunications Suppliers Association (USTSA), and became one of the world's premier organizers of telecom exhibitions and seminars. TIA was formed in April 1988 after a merger of USTSA and the Information and Telecommunications Technologies Group of EIA. EIA began as the Radio Manufacturers Association (RMA) in 1924.

TIA is a member-driven organization. Thirty-one board members are selected from member companies to formulate policy, which is carried out by a staff of more than 50 in the Washington, DC area. There are six issue-oriented standing committees:

- Membership Scope and Development.
- International.
- Marketing and Trade Shows.
- Public Policy and Government Relations.
- Small Company.
- Technical.

Each committee addresses the subject areas of major concern to TIA members. Each committee is chaired by a board member.

TIA's five product-oriented divisions are:

- User Premises Equipment.
- Network Equipment.
- Wireless Communications.
- Fiber Optics.
- Satellite Communications.

Each division is concerned with legislative and regulatory issues of product manufacturers and prepares standards dealing with performance testing and compatibility.



*1-800-565-PSWN*

*<http://www.pswn.gov/>*

Everyone living within the United States expects government entities to respond, mitigate damage, and provide emergency assistance during disasters. Emergency workers are trained to respond to a variety of events, such as natural and technological disasters, terrorist actions, and criminal activities, as well as to conduct other life-saving activities such as search and rescue operations. To be effective before, during, and after their response, public safety officials, throughout all levels of government, must be able to communicate with each other. Currently, Federal, State, and local public safety entities compete for limited radio spectrum, have limited public safety budgets, and face challenges in keeping pace with advances in technology. Moreover, public safety officials operate separate tactical communications networks.

Upon these premises, PSWN's mission is to provide seamless, coordinated, and integrated public safety communications for the safe, effective, and efficient protection of life and property. PSWN's vision of improved communications is shared with local, State, and Federal agencies whose missions encompass the protection of life and property.

## 12. ACRONYMS

AM	Amplitude Modulation
ANSI	American National Standards Institute
APCO	Association of Public-Safety Communications Officials
CSG	Council of State Governments
EIA	Electronics Industry Alliance
FCC	Federal Communications Commission
FM	Frequency Modulation
IRAC	Interdepartmental Radio Advisory Committee
IEEE	Institute of Electrical and Electronics Engineers
IF	Intermediate Frequency
IM	Intermodulation
ITS	Institute for Telecommunication Sciences
ITU	International Telecommunications Union
JAN	Joint Army-Navy
JUSTNET	Justice Technology Information Network
LMR	Land Mobile Radio
MMTA	MultiMedia Telecommunications Association
NASTD	National Association of State Telecommunications Directors
NFPA	National Fire Protection Association
NIJ	National Institute of Justice
NIST	National Institute of Standards and Technology
NLECTC	National Law Enforcement and Corrections Technology Center
NTIA	National Telecommunications and Information Administration
OLES	Office of Law Enforcement Standards
OSHA	Occupational Safety and Health Administration
PSWN	Public Safety Wireless Network
RCC	Radio Common Carrier
RF	Radio Frequency
RG	Radio Grade (very old term)
RMA	Radio Manufacturers Association

SMR	Specialized Mobile Radio
SWR	Standing Wave Ratio
TDR	Time-Domain Reflectometry
TIA	Telecommunications Industry Association
UHF	Ultra-High Frequency
USTSA	United States Telecommunications Suppliers Association
VHF	Very-High Frequency
VSWR	Voltage Standing Wave Ratio
WWW	World Wide Web

### 13. REFERENCES

- [1] NTIA, *Manual of Regulations and Procedures for Federal Frequency Management*, U.S. Government Printing Office, Superintendent of Documents, Washington, DC.
- [2] FCC, "Private Land Mobile Services," Title 47, Code of Federal Regulations, Part 90, Oct. 1, 1997, U.S. Government Printing Office, Superintendent of Documents, Washington, DC.
- [3] FCC, "Private Radio Services Applications and Proceedings," Title 47, Code of Federal Regulations, Part 1, Subpart F, Oct. 1, 1997, U.S. Government Printing Office, Superintendent of Documents, Washington, DC.
- [4] Telecommunications Industry Association, "Project 25, the TIA-Published 102-Series Documents," Jun. 1998, Arlington, VA.
- [5] J.C. Maxwell, "A Dynamical Theory of the Electromagnetic Field," *Proc. Royal Soc.* (London), Vol. 13, p. 531, 1864.
- [6] H. Hertz, "Uber Sehr Schnelle Electriche Schwingungen," *Wied. Ann.*, Vol. 31, p. 421, 1887.
- [7] W.L. Weeks, *Antenna Engineering*, McGraw-Hill, 1968.
- [8] W.F. Snyder and C.L. Bragaw, "Achievement in Radio," NBS Sp. Pub. 555, Oct. 1986.
- [9] V.H. Rumsey, "Reaction Concept in Electromagnetic Theory," *Phys. Rev.*, Vol. 94, No. 6, pp. 1483–1491, Jun. 1954.
- [10] IEEE, "Standard Dictionary of Electrical and Electronics Terms," ANSI/IEEE Std. 100–1996.
- [11] IEEE, "Standard Definitions of Terms for Antennas," IEEE Std. 145–1993.
- [12] J.D. Kraus, *Antennas*, McGraw-Hill, 1950, pp. 69, 81, and 83.
- [13] W.A. Kissick and J.M. Harman, *Communications Range Predictions for Mobile Radio Systems*, NIJ Rept. 201–88, Jan. 1988.
- [14] E.C. Jordan, "Acoustic Models of Radio Antennas," Ohio State Experiment Station, Bulletin 108, 1938.
- [15] Dept. of Defense, "RF Transmission Lines and Fittings," MIL-HDBK-216, Jan. 1962.

- [16] M. Hata, "Empirical Formula for Propagation Loss in Land Mobile Radio Services," *IEEE Trans. on Veh. Tech.*, Vol. VT-29, No. 3, Aug. 1980, pp. 317–325.
- [17] R.D. Jennings and S.J. Paulson, *Communication System Performance Model for VHF and Higher Frequencies*, OT Rept. 77–128, Oct. 1977.
- [18] G.A. Hufford, A.G. Longley, and W.A. Kissick, *A Guide to the Use of the ITS Irregular Terrain Model in the Area Prediction Mode*, NTIA Rept. 82–100, Apr. 1982.
- [19] Telecommunications Industry Association, "Minimum Standards for Communication Antennas, Part I - Base Station Antennas," EIA/TIA-329-B, Sep. 1989.
- [20] National Institute of Justice, *Mobile Antennas*, NIJ Standard-0205.02, Oct. 1997.
- [21] National Institute of Justice, *Fixed and Base Station Antennas*, NIJ Standard-0204.02, Jun. 1998.
- [22] Telecommunications Industry Association, "Minimum Standards for Communication Antennas, Part II - Vehicular Antennas," EIA/TIA-329-B-1, Sep. 1989.
- [23] National Fire Protection Association, *Lightning Protection Code*, NFPA No. 78–1983, Quincy, MA.
- [24] IEEE, "IEEE Standard Safety Levels with Respect to Human Exposure to Radio Frequency Electromagnetic Fields, 3 kHz to 300 GHz," ANSI/IEEE Std. C95.1-1991, revised 1997.



## 14. ACKNOWLEDGMENTS

Numerous manufacturers have kindly granted permission for photographs and measured data for certain of their products to be used in this report. As stated in Footnote 1 (sec. 1), these products and data have been referenced as typical examples or to explain more clearly the technical concepts and principles being presented. In no case does such reference to these sources, their products, and their data imply recommendation or endorsement by the National Institute of Justice, or any other U.S. Government department or agency, nor does it imply that the sources, products, or data identified are necessarily the best available for the selected purpose.

Those manufacturers who have granted permission for photographs of their products or plots of their measured data to be included in this report and the World Wide Web references for the information are the following:

- ©Andrew Corporation

Orlando Park, IL

- ▶ Figure 29(a)—coaxial cable commonly used for LMR base-station applications.

Accessed at <http://www.andrew.com/products/basestation/helix/lowd.asp> on 03/17/99.

- ©Antenna Specialists

Cleveland, OH

- ▶ Figure 6(b)—a typical monopole antenna for mobile applications.

Accessed at <http://www.decibelproducts.com/marketing/catalog/asp-701/pasp-701.html> on 03/12/99.

- ▶ Figure 29(b)—coaxial cable commonly used for LMR mobile applications.

Accessed at [http://allentele.com/antenna/lm\\_cat/lmrpg35.html](http://allentele.com/antenna/lm_cat/lmrpg35.html) on 03/09/99.

- ©Bluewave Antenna Systems Ltd.

Calgary, Alberta, Canada

- ▶ Figure 9—a typical folded-dipole antenna.

Accessed at <http://www.bluewave.ab.ca/bw421e.html> on 03/16/99.

- ©Decibel Products

Dallas, TX

- ▶ Figure 6(a)—a typical monopole antenna for base-station applications.

Accessed at [http://www.allentele.com/antenna/lm\\_cat/lmrpg09.html](http://www.allentele.com/antenna/lm_cat/lmrpg09.html) on 03/15/99.

- ▶ Figure 8—a typical monopole antenna horizontal-plane pattern, base-station application.

Accessed at [http://www.decibelproducts.com/patterns/patterns.cfm?path=patterns/ASP682\\_Series](http://www.decibelproducts.com/patterns/patterns.cfm?path=patterns/ASP682_Series) on 03/12/99.

- ▶ Figure 13—a typical corner-reflector antenna.

Accessed at <http://www.decibelproducts.com/marketing/catalog/db252/pdb252.html> on 03/13/99.

- ▶ Figure 14—a typical corner-reflector antenna horizontal-plane pattern.  
Accessed at [http://www.decibelproducts.com/patterns/patterns.cfm?path=patterns/ASP960\\_Series](http://www.decibelproducts.com/patterns/patterns.cfm?path=patterns/ASP960_Series) on 03/09/99.
- ▶ Figure 16—a typical Yagi antenna.  
Accessed at <http://www.decibelproducts.com/marketing/catalog/asp-960/pasp-962.html> on 03/12/99.
- ▶ Figure 17—a typical Yagi antenna horizontal-plane pattern.  
Accessed at [http://www.decibelproducts.com/patterns/patterns.cfm?path=patterns/ASP816\\_Series](http://www.decibelproducts.com/patterns/patterns.cfm?path=patterns/ASP816_Series) on 03/12/99.
- ▶ Figure 20—a typical log-periodic antenna horizontal-plane pattern.  
Accessed at [http://www.decibelproducts.com/patterns/patterns.cfm?path=patterns/ASP2894\\_Series](http://www.decibelproducts.com/patterns/patterns.cfm?path=patterns/ASP2894_Series) on 03/15/99.
- ▶ Figure 21—a typical vertical array using folded dipoles.  
Accessed at <http://www.decibelproducts.com/marketing/catalog/db404/pdb404.html> on 03/12/99.
- ▶ Figure 24—a typical vertical-plane radiation pattern without “tilt.”  
Accessed at [http://www.decibelproducts.com/patterns/patterns.cfm?path=patterns/DB420\\_Series/420C](http://www.decibelproducts.com/patterns/patterns.cfm?path=patterns/DB420_Series/420C) on 03/15/99.
- ▶ Figure 25—a typical vertical-plane radiation pattern with 8° “tilt.”  
Accessed at [http://www.decibelproducts.com/patterns/patterns.cfm?path=patterns/ASP975\\_Series/ASPD975](http://www.decibelproducts.com/patterns/patterns.cfm?path=patterns/ASP975_Series/ASPD975) on 03/15/99.
- ▶ Figure 30—a VHF duplexer.  
Accessed at <http://www.decibelproducts.com/marketing/catalog/db4060/pdb4060.html> on 03/17/99.
- ▶ Figure 31(a)—a hybrid combiner.  
Accessed at <http://www.decibelproducts.com/marketing/catalog/db43516/pdb4351-2.html> on 03/17/99.
- ▶ Figure 31(b)—a cavity combiner.  
Accessed at <http://www.decibelproducts.com/marketing/catalog/db4360/pdb4360.html> on 03/17/99.
- ▶ Figure 32—an intermodulation suppression device.  
Accessed at <http://www.decibelproducts.com/marketing/catalog/db47104/pdb4713ht.html> on 03/17/99.
- ▶ Figure 33—a multicoupler.  
Accessed at <http://www.decibelproducts.com/marketing/catalog/db8100/pdb8100.html> on 03/17/99.

■ ©R.N. Electronics Ltd.

Mountnessing, Essex, UK

- ▶ Figure 19—a typical log-periodic antenna.  
Accessed at <http://www.rfdesign.co.uk/mlpa30121.htm> on 03/18/99.

**U.S. Department of Justice**  
**Office of Justice Programs**  
810 Seventh Street N.W.  
Washington, DC 20531

**Office of Justice Programs**  
**World Wide Web Site:**  
*<http://www.ojp.usdoj.gov>*

**National Institute of Justice**  
**World Wide Web Site:**  
*<http://www.ojp.usdoj.gov/nij>*

---