

**ASSESSMENT OF COMPATIBILITY  
BETWEEN ULTRAWIDEBAND (UWB)  
SYSTEMS AND GLOBAL POSITIONING  
SYSTEM (GPS) RECEIVERS**



***SPECIAL PUBLICATION***

---

U.S. DEPARTMENT OF COMMERCE Ž National Telecommunications and Information Administration

A solid black horizontal bar at the bottom of the page.

# **ASSESSMENT OF COMPATIBILITY BETWEEN ULTRAWIDEBAND (UWB) SYSTEMS AND GLOBAL POSITIONING SYSTEM (GPS) RECEIVERS**

**David S. Anderson  
Edward F. Drocella  
Steven K. Jones  
Mark A. Settle**



**U.S. DEPARTMENT OF COMMERCE  
Donald Evans, Secretary**

John F. Sopko, Acting Assistant Secretary  
for Communications and Information

**February 2001**

## **ACKNOWLEDGMENTS**

The authors wish to thank the many organizations and persons who contributed to the completion of this report. In particular we wish to thank the Federal agency representatives on the Interdepartment Radio Advisory Committee and the Interagency GPS Executive Board for providing vital comments, information, and review of this report. We also acknowledge the written and verbal comments provided by the US GPS Industry Council, and the Ultrawideband Industry during the public comment process, open public meetings, and one-on-one discussions.

We wish to thank the GPS Joint Program Office, the Department of Aeronautics and Astronautics of Stanford University, and the NTIA's Institute for Telecommunication Sciences for their support and work in the measurement process that is fundamental to this report. We also wish to thank the contributing NTIA employees: Paul Roosa, Robert Sole, and Mike Doolan.

# EXECUTIVE SUMMARY

## BACKGROUND

The study described in this report was undertaken by the National Telecommunications and Information Administration (NTIA) in response to a Federal Communications Commission (FCC) Notice of Proposed Rule Making (NPRM) concerning the operation of a new class of spectrum-dependent devices, designated as ultrawideband (UWB) devices under the FCC's rules and regulations in Part 15 of Title 47 of the Code of Federal Regulations (CFR). This NPRM raises a number of questions and concerns regarding the electromagnetic compatibility (EMC) of the proposed UWB transmitting devices to those spectrum-dependent systems currently in operation. The NTIA, as the Executive Branch agency principally responsible for developing and articulating domestic and international telecommunications policy affecting Federal Government spectrum users, is particularly interested in the potential for interference to telecommunications infrastructure utilizing Federal Government spectrum for critical and/or safety-of-life functions, many of which operate in spectrum designated as the "restricted frequency bands." These frequency bands have been designated as restricted because the systems operating in them provide critical safety functions. Before NTIA can agree to emissions from UWB devices in restricted frequency bands used by critical Federal Government radiocommunication systems, it must ensure that there is no potential interference introduced from their proposed operations. The Global Positioning System (GPS) is an example of a critical radionavigation system that operates in several of the restricted frequency bands.

In recognition of the need to ensure protection of an existing spectrum asset as important as GPS, NTIA accepted funding from the Interagency GPS Executive Board (IGEB) and the Federal Aviation Administration (FAA) to conduct an assessment of the EMC between proposed UWB devices<sup>1</sup> and GPS receivers.

## OBJECTIVE

The primary objective of this study is to define maximum allowable UWB equivalent isotropically radiated power (EIRP)<sup>2</sup> levels that can be tolerated by GPS receivers, when used within various operational applications, without causing degradation to GPS operations. These EIRP levels

---

<sup>1</sup> The UWB emissions considered in this report are limited to those using a burst of a series of impulse-like signals. However, there are several ways of defining UWB signals, one being an emission that has an instantaneous bandwidth of at least 25% of the center frequency of the device. There are also several ways of generating very wide signals, including the use of spread spectrum and frequency hopping techniques.

<sup>2</sup> The computation of EIRP is in terms of the average power of the UWB signal for all cases considered in this report. This average power is based on root-mean-square (RMS) voltage.

will then be compared to the emission levels derived from the limits specified for intentional radiators in C.F.R., Title 47, Part 15.209 to assess the applicability of the Part 15 limits to UWB devices.<sup>3</sup>

## **GPS SYSTEM DESCRIPTION**

The GPS is a space-based radionavigation satellite system providing precise position, velocity, and time information on a continuous, worldwide basis. The GPS space segment consists of a 24-satellite constellation with the satellites distributed in six orbital planes at an approximate altitude of 20,000 km. With the current configuration of the GPS constellation, there are typically from 6 to 11 satellites simultaneously visible from any point on the surface of the Earth. However, within a metropolitan area, the number of visible satellites is often reduced due to blockage from buildings or other man-made structures. GPS satellites currently transmit a spread spectrum signal using a multiple access capability known as code division multiple access (CDMA) on two microwave frequencies: Link 1 (L1) on 1575.42 MHz, and Link 2 (L2) on 1227.60 MHz. A civil coarse/acquisition (C/A) code and a quadrature-phase precision (P) code are multiplexed on the GPS L1 frequency while only the P-code is modulated on the L2 carrier. The C/A signal supports the standard positioning service and the P signal supports the precise positioning service.

A modernization effort is currently ongoing that will add two new civil signals to the GPS system. A C/A-like signal has been proposed for addition on L2, and a new signal structure has been defined for broadcast in a recently allocated Radionavigation-Satellite Service frequency band (1164-1188 MHz) and will be designated Link 5 (L5).

## **GPS APPLICATIONS**

GPS will become the cornerstone for air navigation for all phases of flight (en-route, precision and non-precision approach) and is the preferred navigation system for maritime operations. In order to meet the exacting standards required from a safety-of-life system, the U.S. Government has either developed, or is developing augmentations to the basic GPS system for aviation, maritime, and land use. The Wide Area Augmentation System (WAAS) and the Local Area Augmentation System (LAAS) are under development to enhance aviation uses of GPS. Differential GPS (DGPS) has been fielded to augment GPS to meet maritime harbor and harbor approach requirements, and for use in intercoastal and inland waterways. GPS is also fast becoming an integral component of position determination applications such as Enhanced-911 (E-911) and personal location and medical tracking devices. The telecommunications, banking, and power distribution industries represent another sector that uses GPS for network synchronization timing. Moreover, GPS has proven to be a powerful enabling technology that has driven the creation of many new industries. GPS also provides the U.S. military and its allies with positioning, navigation, and timing capabilities that are critical to peacetime and wartime national and global security operations.

---

<sup>3</sup> The existing Part 15 measurement procedure uses an average logarithm detector process and is not equivalent to measurements using an RMS detector process.

## APPROACH

A two-part approach consisting of both a measurement and an analysis component was adopted for this assessment. NTIA's Institute for Telecommunication Sciences (ITS) measured the interference susceptibility of various GPS receiver architectures to a set of UWB waveforms. Utilizing the measured GPS receiver interference susceptibility levels, analyses were performed by the NTIA Office of Spectrum Management (OSM) for various operational scenarios to determine the maximum allowable UWB EIRP level that can be tolerated by GPS receivers before performance degradation is realized.

### Measurement Component

A measurement plan was developed to guide the measurement component of this study. In this plan, the performance criteria to be used to assess a performance degradation to the GPS receivers under measurement were established, a list of candidate GPS receivers to be measured was defined, and the UWB signal structures to be considered were identified. A set of procedures to be used in performing the measurements was also developed. The plan was published in the Federal Register and public comment was solicited. Comments were received from seven parties. Each set of comments was considered and detailed responses provided. When deemed appropriate, the information contained in the received comments was incorporated into the plan.

**GPS Receivers Selected for Testing.** Since GPS receivers are used in many applications, NTIA decided that rather than attempt to measure across the space of GPS applications, this study would instead attempt to measure across the space of GPS receiver architectures. One receiver from each of three basic GPS receiver architectures was identified for inclusion in the measurements. The receiver architectures represented are: C/A-code tracking receivers (which make up a significant share of the civil GPS receivers in use today), semi-codeless receivers (used in low-dynamic applications requiring high precision), and C/A-code tracking receivers employing multiple, narrowly-spaced correlators to enhance accuracy and mitigate the effects of multipath. These three GPS receiver architectures encompass most, if not all, of the existing GPS applications.<sup>4</sup> In order to address particular concerns related to the aviation use of GPS, a Technical Standard Order (TSO)-C129a compliant aviation receiver (currently used in en-route and non-precision approach applications) was also included as a part of this measurement effort.<sup>5</sup>

---

<sup>4</sup> This effort did not consider the potential impact of UWB operations to military GPS receivers.

<sup>5</sup> Due to unanticipated delays in the execution of the measurement component of this study, the measured data for the narrowly-spaced GPS correlator receiver architecture and the TSO-C129a-compliant receiver were not included in this report. This data will be provided as an addendum to this report as it becomes available.

**UWB Signals Examined.** NTIA identified 32 UWB signal permutations for examination with respect to their interference potential to GPS receivers. These signal permutations were judged to be representative of those expected to be used in UWB applications. For each of four pulse repetition frequencies (PRFs); 100 kHz, 1 MHz, 5 MHz, and 20 MHz, eight distinct UWB waveforms were generated by combining four modulation types (constant PRF, On-Off Keying (OOK), 2% relative dither, and 50% absolute dither) and two states of gating (100% and 20%). The PRF defines the number of pulses transmitted per unit time (one second). The PRF governs both the magnitude and spacing of the spectral lines, and the percentage of time that pulses are present. Gating refers to the process of distributing pulses in bursts by employing a programmed set of periods where the UWB transmitter is turned on or off for a period of pulses. For the measurements performed in this study, the gated UWB signal utilized a scheme where a burst of pulses lasting 4 milliseconds (ms) was followed by a 16 ms period when no pulses were transmitted. This is referred to as 20% gating, because the UWB pulses are transmitted 20% of the time. The signal permutations depicted within this report as 100% gating, define a signal where pulses are transmitted 100% of the time. OOK refers to the process of selectively turning off or eliminating individual pulses to represent data bits. Dithering refers to the random or pseudo-random spacing of the pulses. Two forms of dithered UWB signals were considered in this effort. These are an absolute referenced dither, where the pulse period is varied in relation to the absolute clock, and a relative referenced dither, where the pulse spacing is varied relative to the previous pulse. The data collected from these measurements are applicable only to the UWB signal permutations that were considered in this assessment. No attempt should be made to extrapolate this data beyond these particular UWB parameters.

**Performance Criteria Used.** After researching available technical standards and other open literature, a set of criteria that was not application specific was adopted for assessing the performance of the GPS receivers in this measurement effort. The two performance criteria examined were “break-lock” and “reacquisition.” Break-lock refers to the loss of signal lock between the GPS receiver and a GPS satellite. This condition occurs when an interfering signal reduces the carrier-to-noise density ( $C/N_0$ ) ratio (i.e., an increase in the undesired signal level,  $N_0$ , relative to the desired signal level,  $C$ ) to such an extent that the GPS receiver can no longer adequately determine the pseudorange (the initial/uncorrected measure of distance from a single GPS satellite to a receiver) for the given satellite signal.

The reacquisition threshold is defined as the UWB power level that results in an abrupt increase in reacquisition time. To determine the impact on reacquisition time, the signal from the GPS satellite of interest was interrupted and a 50-meter step in pseudorange was introduced over a 10-second period. This was done to simulate a GPS-equipped vehicle passing behind a building or other obstacle in the satellite-to-receiver path, causing a temporary loss-of-lock between the GPS receiver and the satellite of interest. As the vehicle clears the obstacle and again becomes visible, the GPS receiver must be able to reacquire the lost satellite signal in the presence of UWB energy in a time consistent with that associated with no UWB energy present.

**Measurements Performed.** ITS performed closed system (conducted) measurements to assess the potential impact to each of the GPS receivers from both a single UWB transmitter (one-on-one) interaction from a multiple UWB transmitter (aggregate) interaction. To examine the applicability of the conducted measurements, the effects of the GPS antenna on the radiated signals within the frequency band of interest were measured. Measurements were performed wherein the UWB signal was radiated and received within an anechoic chamber to prevent outside interference sources from affecting the results. Amplitude probability distribution (APD) measurements were also performed for each of the UWB signal permutations considered in this effort, to aid in classifying the UWB signals. The complete measurement data set is presented in a separate report published by ITS.

### **Analysis Component**

The data collected from the measurements were used in a subsequent analysis effort performed by the NTIA OSM to calculate the maximum allowable EIRP that can be emitted from a UWB transmitter without exceeding the measured interference susceptibility level. A source-path-receiver analysis was performed to calculate these maximum allowable EIRP levels for both a single UWB transmitter-to-GPS receiver interaction and for the case of an aggregate of UWB transmitters-to-GPS receiver interaction. In performing these analyses, related parameters were determined from operational scenarios, which define the conditions under which proposed UWB devices may be in proximity to GPS receivers in operational applications. These operational scenarios were developed in open, public meetings with participation from UWB and GPS manufacturers and users. The specific proposals for operational scenarios to be considered in the NTIA study included GPS receivers used in the following applications: terrestrial<sup>6</sup> (e.g., public safety applications such as cellular phone embedded E-911 and emergency response vehicle navigation, geographic information systems, precision machine control, and general operations), maritime navigation (in constricted waterways, harbors, docking, and lock operations); railway operations (positive train control), surveying, and aviation (en-route navigation and non-precision approach). These scenarios do not represent all possible applications of GPS, however, they do represent a reasonable bound on the parameters necessary to perform the broadly based analyses. For example, the separation distances represented in these scenarios range from a minimum of 2 meters for the embedded E-911 scenario, to a maximum of approximately 300 meters (1000 feet) for the en-route aviation scenario.

## **RESULTS**

This report documents the results of the measurement and analysis program conducted by NTIA. Policy recommendations and/or guidance with respect to proposed UWB operations are not included within the scope of this effort. The following paragraphs discuss the findings of this program.

---

<sup>6</sup> Within the context of this report, terrestrial refers to land-based operations.



## **Measurement Results**

The results from the measurement component of this study indicate that both the C/A-code tracking GPS receiver and the semi-codeless GPS receiver demonstrate a tolerance to all of the UWB signal permutations examined with a PRF of 100 kHz. For the scenarios considered in this assessment, aggregate effects were deemed not to be a concern with respect to those UWB waveforms with a PRF of 100 kHz. When the PRF was increased to 1 MHz, the C/A-code receiver began to show continuous wave (CW)-like interference susceptibility to the unmodulated UWB signal permutations at low power levels. When the PRF was increased to 5 MHz and then to 20 MHz, CW-like interference effects to the C/A-code receiver were observed to be more prevalent.

The measurements also show that dithering of the UWB pulses in the time domain, using the techniques considered in this assessment, can be effective in spreading the spectral lines in the frequency domain, making the effective signal appear more noise-like. The GPS C/A-code receiver showed approximately 10 dB less sensitivity to these noise-like UWB signals as compared to those UWB signals deemed as CW-like. For PRFs of 1 MHz, 5 MHz, and 20 MHz, some of the UWB waveforms caused an effect similar to low duty cycle pulsed interference, to which the GPS C/A-code receiver is relatively tolerant. However, the multiple-entry (aggregate) measurements indicate that this advantage is lost when a multiple of as few as three of these UWB signals with equivalent power levels at the GPS receiver input are considered in aggregation. The aggregate measurements also verify that when multiple noise-like UWB signals are considered with equivalent power levels at the GPS receiver input, the effective aggregate signal level in the receiver intermediate frequency (IF) bandwidth is determined by adding the average power of each of the UWB signals.

The measured performance thresholds for the C/A-code GPS receiver were compared with the interference protection criteria documented within the RTCA and the ITU-R. The results of this comparison indicate agreement between the performance thresholds measured as a part of this study and the protection criteria documented in the national and international standards.

The semi-codeless receiver measured in this assessment showed a susceptibility similar to what would be expected from noise-like interference for all of the UWB signal permutations employing PRFs of 1, 5, and 20 MHz. The semi-codeless GPS receiver was also observed to be more susceptible than the C/A-code receiver to noise-like interference.

A comparison between the radiated and conducted path measurements of the APD and the analyses of the magnitude distortion and the variations in the group delay indicate that the GPS antenna gain in the direction of the interference source is the only parameter that needs to be considered in the source-path-receiver analyses. The GPS antenna does not offer any additional mitigating effects to the portion of the UWB signal within the GPS operating band.

The measurements performed in this study assumed GPS operation in the tracking mode of operation (i.e., the GPS receiver was allowed to acquire the satellites necessary to obtain a navigation solution before UWB interference was introduced). The initial (cold-start) acquisition mode of GPS receiver operation is known to be more sensitive to interference than the tracking mode. However, measurements of GPS receiver susceptibility to interference when operating in the cold-start acquisition mode are difficult to perform. Within RTCA and International Telecommunication Union-Radiocommunication Sector (ITU-R) working groups, the initial acquisition mode of operation is accounted for by reducing the tracking mode interference protection levels by 6 dB. This factor was not considered in the analyses performed as a part of this study.

## **Analysis Results**

In the analysis component of this study, NTIA determined the maximum allowable EIRP level for the different UWB signal permutations, using the operational scenarios proposed in the public meetings. The results of the analysis are summarized in Tables 1 through 4. Each table corresponds to a UWB PRF examined in the analysis. The tables provide a description of the: operational scenario; UWB signal characteristics; GPS receiver architecture; interfering signal classification; interference threshold; and the computed values of maximum allowable EIRP. The values of maximum allowable EIRP shown in the Tables 1 through 4 are for a single UWB device interaction, and they represent the highest EIRP at which UWB devices can operate without exceeding the measured performance threshold of the GPS receiver architecture under consideration for the conditions specified by the operational scenarios.

Tables 1 through 4 also include a comparison of the computed maximum allowable EIRP level with the current Part 15 level of -71.3 dBW/MHz. When the interference effects are classified as pulse-like or noise-like, the maximum allowable EIRP level can be directly compared to the current Part 15 level. When the interference effect is classified as CW-like, the maximum allowable EIRP level can be directly compared to the Part 15 level, only if it is assumed that there is a single spectral line in the measurement bandwidth. For those entries where the difference between the current Part 15 level and the computed maximum allowable EIRP level is shown as negative, no additional attenuation below the current Part 15 level is necessary. For those entries where the difference is shown as positive, the value specifies the additional attenuation below the current Part 15 level that is necessary to satisfy the measured performance threshold of the GPS receiver architecture under consideration.

**Table 1. Summary of Analysis Results (PRF = 100 kHz)**

Operational Scenario Description					UWB Signal Characteristics			GPS Receiver Architecture	Classification of Interfering Signal	Maximum Interference Threshold (dBW/MHz)	Maximum Allowable EIRP (dBW/MHz)	Comparison with the Current Part 15 Level (dB)
GPS Application	UWB Single	UWB Multiple	UWB Indoor	UWB Outdoor	PRF (MHz)	Gating %	Mod.					
Terrestrial	X			X	0.1	100	None	C/A-code	Pulse-Like	-112.6	-73.2	1.9
Terrestrial		X	X		0.1	100	None	C/A-code	Pulse-Like	-112.6	-57.6	-13.7
Terrestrial		X		X	0.1	100	None	C/A-code	Pulse-Like	-112.6	-62.3	-9
Maritime		X	X		0.1	100	None	C/A-code	Pulse-Like	-112.6	-41.7	-29.6
Maritime		X		X	0.1	100	None	C/A-code	Pulse-Like	-112.6	-48.1	-23.2
Railway		X	X		0.1	100	None	C/A-code	Pulse-Like	-112.6	-56.3	-15
Railway		X		X	0.1	100	None	C/A-code	Pulse-Like	-112.6	-57.8	-13.5
Surveying	X			X	0.1	20	2% Rel.	Semi-Codeless	Noise-Like	-138	-81.1	9.8
Surveying		X		X	0.1	20	2% Rel.	Semi-Codeless	Noise-Like	-138	-81.2	9.9
Aviation-NPA		X		X	0.1	100	None	C/A-code	Pulse-Like	-112.6	-52.9	-18.4
Aviation-ER		X	X		Note 1	Note 1	Note 1	C/A-code	Noise-Like	-134.8	-76.6 <sup>2</sup>	5.3
Aviation-ER		X		X	Note 1	Note 1	Note 1	C/A-code	Noise-Like	-134.8	-85.6 <sup>2</sup>	14.3

**Notes:** En-Route Navigation (ER), Non-Precision Approach (NPA)  
1. In this operational scenario, it is assumed that there is a large enough number of UWB devices such that independent of the individual UWB signal parameters, the aggregate effect causes noise-like interference.  
2. This maximum allowable EIRP is based on an assumed density of 200 UWB devices per square kilometer transmitting simultaneously .

**Table 2. Summary of Analysis Results (PRF = 1 MHz)**

Operational Scenario Description					UWB Signal Characteristics			GPS Receiver Architecture	Classification of Interfering Signal	Maximum Interference Threshold <sup>1</sup>	Maximum Allowable EIRP <sup>3</sup>	Comparison with the Current Part 15 Level (dB)
GPS Application	UWB Single	UWB Multiple	UWB Indoor	UWB Outdoor	PRF (MHz)	Gating %	Mod.					
Terrestrial	X			X	1	100	None	C/A-code	CW-Like	-143.7	-104.3	33
Terrestrial	X			X	1	100	2% Rel.	C/A-code	Pulse-Like	-131	-91.6	20.3
Terrestrial		X	X		1	100	None	C/A-code	CW-Like	-143.7	-88.7	17.4
Terrestrial		X	X		1	20 & 100	Multiple	C/A-code	Noise-Like	-134.5	-85.5	14.2
Terrestrial		X		X	1	100	None	C/A-code	CW-Like	-143.7	-93.4	22.1
Terrestrial		X		X	1	20 & 100	Multiple	C/A-code	Noise-Like	-134.5	-90.2	18.9
Maritime		X	X		1	100	None	C/A-code	CW-Like	-143.7	-72.8	1.5
Maritime		X	X		1	20 & 100	Multiple	C/A-code	Noise-Like	-134.5	-69.6	-1.7
Maritime		X		X	1	100	None	C/A-code	CW-Like	-143.7	-79.2	7.9
Maritime		X		X	1	20 & 100	Multiple	C/A-code	Noise-Like	-134.5	-76	4.7
Railway		X	X		1	100	None	C/A-code	CW-Like	-143.7	-87.4	16.1
Railway		X	X		1	20 & 100	Multiple	C/A-code	Noise-Like	-134.5	-83.0	11.7
Railway		X		X	1	100	None	C/A-code	CW-Like	-143.7	-88.9	17.6
Railway		X		X	1	20 & 100	Multiple	C/A-code	Noise-Like	-134.5	-84.5	13.2
Surveying	X			X	1	100	50% Abs.	Semi-Codeless	Noise-Like	-151	-94.1	22.8
Surveying		X		X	1	100	50% Abs.	Semi-Codeless	Noise-Like	-151	-94.2	22.9
Aviation-NPA		X		X	1	100	None	C/A-code	CW-Like	-143.7	-84	12.7
Aviation-NPA		X		X	1	20 & 100	Multiple	C/A-code	Noise-Like	-134.5	-80.8	9.5
Aviation-ER		X	X		Note 2	Note 2	Note 2	C/A-code	Noise-Like	-134.8	-76.6 <sup>3</sup>	5.3
Aviation-ER		X		X	Note 2	Note 2	Note 2	C/A-code	Noise-Like	-134.8	-85.6 <sup>3</sup>	14.3

**Notes:** En-Route Navigation (ER), Non-Precision Approach (NPA)

1. When the interference effect has been classified as pulse-like or noise-like, the value is expressed in units of dBW/MHz. The value is expressed in units of dBW when the interference effect has been classified as CW-like.

2. In this operational scenario, it is assumed that there is a large enough number of UWB devices, such that independent of the individual UWB signal parameters the aggregate effect causes noise-like interference.

3. This maximum allowable EIRP is based on an assumed density of 200 UWB devices per square kilometer transmitting simultaneously.

**Table 3. Summary of Analysis Results (PRF = 5 MHz)**

Operational Scenario Description					UWB Signal Characteristics			GPS Receiver Architecture	Classification of Interfering Signal	Maximum Interference Threshold <sup>1</sup>	Maximum Allowable EIRP <sup>3</sup>	Comparison with the Current Part 15 Level (dB)
GPS Application	UWB Single	UWB Multiple	UWB Indoor	UWB Outdoor	PRF (MHz)	Gating %	Mod.					
Terrestrial	X			X	5	100	None	C/A-code	CW-Like	-145.5	-106.1	34.8
Terrestrial	X			X	5	20	50% Abs.	C/A-code	Pulse-Like	-105	-65.6	-5.7
Terrestrial	X			X	5	100	50% Abs.	C/A-code	Noise-Like	-137	-97.6	26.3
Terrestrial		X	X		5	100	None	C/A-code	CW-Like	-145.5	-90.5	19.2
Terrestrial		X	X		5	100	50% Abs.	C/A-code	Noise-Like	-137	-88	16.7
Terrestrial		X		X	5	100	None	C/A-code	CW-Like	-145.5	-95.2	23.9
Terrestrial		X		X	5	100	50% Abs.	C/A-code	Noise-Like	-137	-92.7	21.4
Maritime		X	X		5	100	None	C/A-code	CW-Like	-145.5	-74.6	3.3
Maritime		X	X		5	100	50% Abs.	C/A-code	Noise-Like	-137	-72.1	0.8
Maritime		X		X	5	100	None	C/A-code	CW-Like	-145.5	-81	9.7
Maritime		X		X	5	100	50% Abs.	C/A-code	Noise-Like	-137	-78.5	7.2
Railway		X	X		5	100	None	C/A-code	CW-Like	-145.5	-89.2	17.9
Railway		X	X		5	100	50% Abs.	C/A-code	Noise-Like	-137	-85.5	14.2
Railway		X		X	5	100	None	C/A-code	CW-Like	-145.5	-90.7	19.4
Railway		X		X	5	100	50% Abs.	C/A-code	Noise-Like	-137	-87.0	15.7
Surveying	X			X	5	20 & 100	50% Abs.	Semi-Codeless	Noise-Like	-151	-94.1	22.8
Surveying		X		X	5	20 & 100	50% Abs.	Semi-Codeless	Noise-Like	-151	-94.2	22.9
Aviation-NPA		X		X	5	100	None	C/A-code	CW-Like	-145.5	-85.8	14.5
Aviation-NPA		X		X	5	100	50% Abs.	C/A-code	Noise-Like	-137	-83.3	12
Aviation-ER		X	X		Note 2	Note 2	Note 2	C/A-code	Noise-Like	-134.8	-76.6 <sup>3</sup>	5.3
Aviation-ER		X		X	Note 2	Note 2	Note 2	C/A-code	Noise-Like	-134.8	-85.6 <sup>3</sup>	14.3

**Notes:** En-Route Navigation (ER), Non-Precision Approach (NPA)

1. When the interference effect has been classified as pulse-like or noise-like, the value is expressed in units of dBW/MHz. The value is expressed in units of dBW when the interference effect has been classified as CW-like.
2. In this operational scenario, it is assumed that there is a large enough number of UWB devices, such that independent of the individual UWB signal parameters the aggregate effect causes noise-like interference.
3. This maximum allowable EIRP is based on an assumed density of 200 UWB devices per square kilometer transmitting simultaneously.

**Table 4. Summary of Analysis Results (PRF = 20 MHz)**

Operational Scenario Description					UWB Signal Characteristics			GPS Receiver Architecture	Classification of Interfering Signal	Maximum Interference Threshold <sup>1</sup>	Maximum Allowable EIRP <sup>3</sup>	Comparison with the Current Part 15 Level (dB)
GPS Application	UWB Single	UWB Multiple	UWB Indoor	UWB Outdoor	PRF (MHz)	Gating %	Mod.					
Terrestrial	X			X	20	20	OOK	C/A-code	CW-Like	-146.3	-106.9	35.6
Terrestrial	X			X	20	20	50% Abs.	C/A-code	Pulse-Like	-135	-95.6	24.3
Terrestrial	X			X	20	100	50% Abs.	C/A-code	Noise-Like	-138	-98.6	27.3
Terrestrial		X	X		20	20	OOK	C/A-code	CW-Like	-146.3	-91.3	20
Terrestrial		X	X		20	100	50% Abs.	C/A-code	Noise-Like	-138	-89	17.7
Terrestrial		X		X	20	20	OOK	C/A-code	CW-Like	-146.3	-96	24.7
Terrestrial		X		X	20	100	50% Abs.	C/A-code	Noise-Like	-138	-93.7	22.4
Maritime		X	X		20	20	OOK	C/A-code	CW-Like	-145	-75.4	4.1
Maritime		X	X		5	100	50% Abs.	C/A-code	Noise-Like	-138	-73.1	1.8
Maritime		X		X	20	20	OOK	C/A-code	CW-Like	-145	-81.8	10.5
Maritime		X		X	20	100	50% Abs.	C/A-code	Noise-Like	-138	-79.5	8.2
Railway		X	X		20	20	OOK	C/A-code	CW-Like	-145	-90	18.7
Railway		X	X		20	100	50% Abs.	C/A-code	Noise-Like	-138	-86.5	15.2
Railway		X		X	20	20	OOK	C/A-code	CW-Like	-145	-91.5	20.2
Railway		X		X	20	100	50% Abs.	C/A-code	Noise-Like	-138	-88.0	16.7
Surveying	X			X	20	100	50% Abs. & 2% Rel.	Semi-Codeless	Noise-Like	-149.5	-92.6	21.3
Surveying		X		X	20	100	50% Abs. & 2% Rel.	Semi-Codeless	Noise-Like	-149.5	-92.7	21.4
Aviation-NPA		X		X	20	20	OOK	C/A-code	CW-Like	-145	-86.6	15.3
Aviation-NPA		X		X	20	100	50% Abs.	C/A-code	Noise-Like	-138	-84.3	13
Aviation-ER		X	X		Note 2	Note 2	Note 2	C/A-code	Noise-Like	-134.8	-76.6 <sup>3</sup>	5.3
Aviation-ER		X		X	Note 2	Note 2	Note 2	C/A-code	Noise-Like	-134.8	-85.6 <sup>3</sup>	14.3

**Notes:** En-Route Navigation (ER), Non-Precision Approach (NPA)

1. When the interference effect has been classified as pulse-like or noise-like, the value is expressed in units of dBW/MHz. The value is expressed in units of dBW when the interference effect has been classified as CW-like.
2. In this operational scenario, it is assumed that there is a large enough number of UWB devices, such that independent of the individual UWB signal parameters the aggregate effect causes noise-like interference.
3. This maximum allowable EIRP is based on an assumed density of 200 UWB devices per square kilometer transmitting simultaneously.

Certain observations were made based on a review of the last column in Tables 1 through 4. This column shows the difference between the current Part 15 level of -71.3 dBW/MHz (considered as an average power limit) and the computed maximum allowable EIRP levels necessary to achieve EMC with the GPS receivers used in the applications represented by the operational scenarios considered in this study.

An examination of Table 1 (PRF = 100 kHz) reflects the measurement observation that a GPS C/A-code receiver is relatively tolerant to low-duty cycle pulsed interference. For the 100 kHz UWB waveforms, the limiting-case operational scenario involving a C/A-code GPS receiver (i.e., aviation en-route navigation assuming outdoor UWB device operations) indicates that a maximum allowable EIRP level of 14.3 dB below the existing Part 15 level is necessary to satisfy the measured performance threshold of the GPS receiver considered within this scenario. This calculation is based on an assumed density of active UWB devices on the order of 200/km<sup>2</sup>. However, if UWB operations with a PRF of 100 kHz are limited only to applications such as ground penetrating and through-the-wall imaging, the actual UWB device density will likely be less than what was assumed in the analysis. For example, if the actual UWB device density for these types of applications is assumed to be on the order of 20/km<sup>2</sup>, then the calculated maximum allowable EIRP level will increase by 10 dB. Under these conditions, a maximum allowable EIRP of 4.3 dB below the existing Part 15 level for outdoor UWB operations would satisfy the restrictions imposed by the aviation en-route navigation operational scenario. Since this scenario represents the limiting case for operations using GPS C/A-code receivers, this maximum allowable EIRP level would also apply to the use of GPS C/A-code receivers in the remaining operational scenarios considered as a part of this study.

Table 1 also shows the effect of the 100 kHz PRF UWB waveforms on the surveying operational scenario in which the semi-codeless GPS receiver architecture is used. It is noted that surveyors are not the only users of GPS receiver employing semi-codeless techniques; however, the operational scenario is considered to be fairly representative of other uses of this receiver architecture. As observed from the measurement results, the semi-codeless receiver is more susceptible than the C/A-code receiver to interference that is classified as pulse-like or noise-like. As a result, the analysis indicates that for the surveying operational scenario, the UWB signals examined in this study would require a maximum allowable EIRP that is 10 dB below the current Part 15 level to satisfy the measured performance threshold for the semi-codeless receiver architecture. In summary, when considering the 100 kHz PRF UWB waveforms, a maximum allowable EIRP level on the order of 10.0 to 14.3 dB below the current Part 15 level (depending on the assumed UWB device density associated with likely applications for a 100 kHz PRF) is necessary to satisfy the performance criteria for the GPS receiver architectures associated with the operational scenarios considered in this study.

Tables 2 through 4 (UWB waveforms with PRFs of 1, 5, and 20 MHz) show that the maximum allowable EIRP level necessary to satisfy the measured GPS performance criteria must be less than the current Part 15 level for most of the operational scenarios considered. Those interactions that involve operational scenario/UWB signal parameter combinations that require an attenuation of 20 dB or more

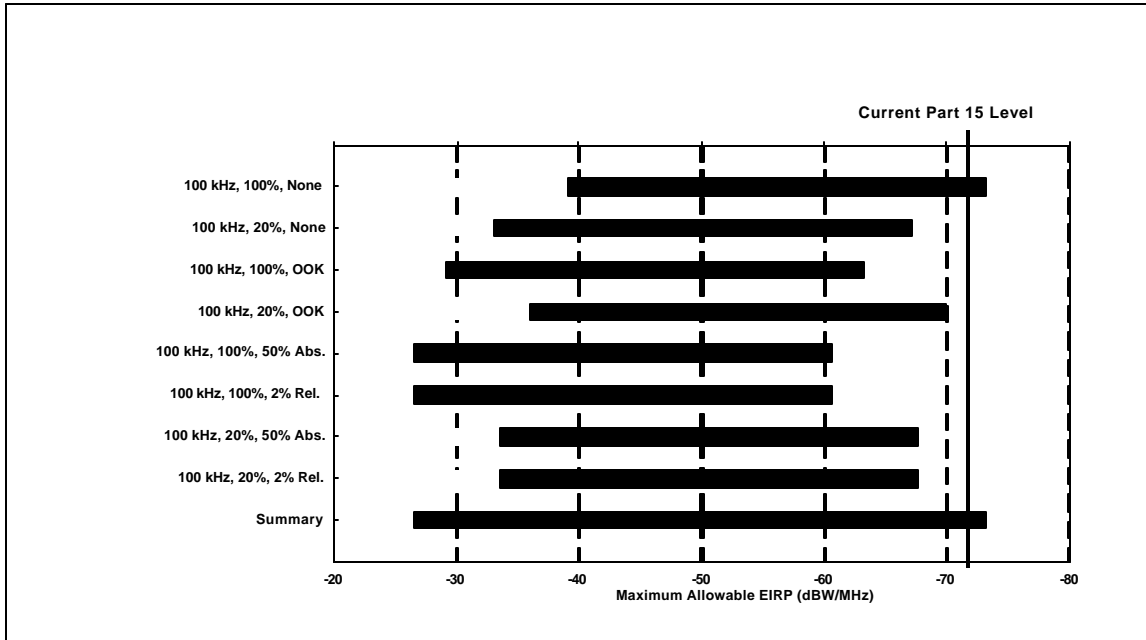
below the Part 15 level were selected for closer inspection. This examination indicates that in most of these cases, the interactions involve: 1) UWB waveforms that were deemed CW-like in their interference effect to the GPS C/A-code receiver architecture, for which the measurements indicate a greater interference susceptibility; 2) applications using semi-codeless receivers, which were determined from the measurements to be more susceptible to UWB waveforms classified as noise-like or pulse-like interference; or 3) operational scenarios in which the UWB transmitter is considered to be operating at a close distance (within several meters) relative to the GPS receiver. This data suggests that if the spectral line content of the UWB waveforms could be removed from consideration, perhaps through regulation, there still remains a number of interactions involving noise-like UWB waveforms at these PRFs for which the EIRP levels would have to be attenuated to levels up to 27 dB below the current Part 15 level.

As shown in Tables 1 through 4, the results of the analysis indicates that the maximum allowable EIRP necessary to satisfy the measured performance thresholds of the GPS receivers considered in this study is very dependent on the UWB signal structure. This is consistent with the findings of the measurement effort where the performance of the GPS receivers tested was also observed to be dependent on the UWB signal structure. Figures 1 through 4 display computed maximum allowable EIRP levels for those UWB signal permutations that were classified within this study as pulse-like, noise-like, and CW-like with respect to their interference effects on the GPS C/A-code receiver. The values reported in these charts represent the values of the maximum allowable EIRP level determined from an analysis of each UWB signal permutation in potential interactions with the GPS C/A-code receiver that were defined by all of the operational scenarios considered in the study.

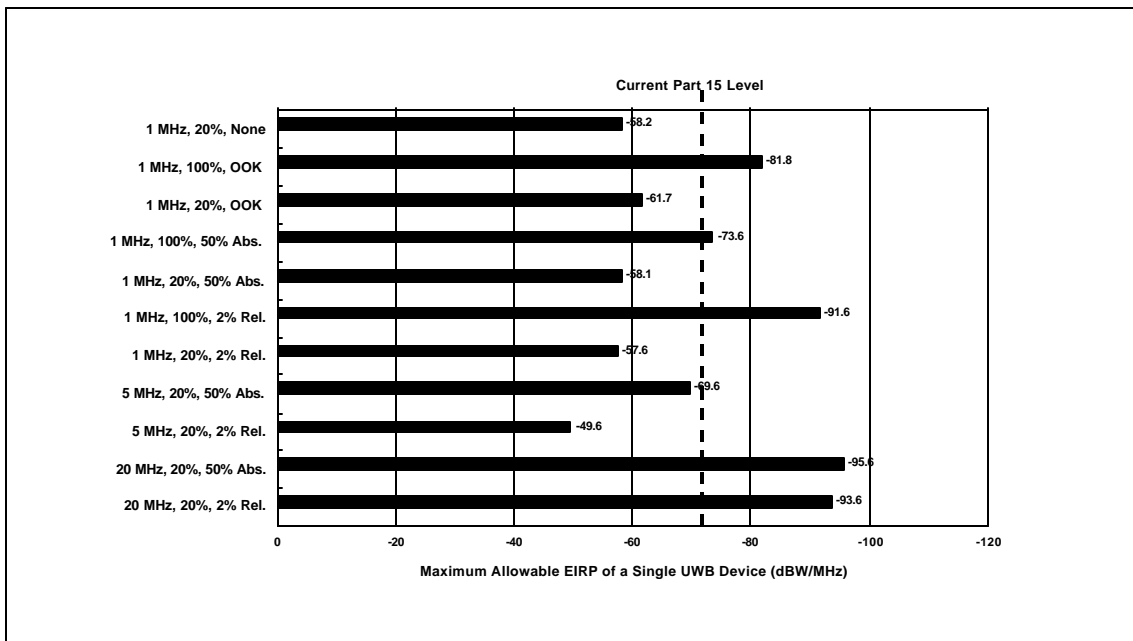
For the operational scenarios that considered multiple UWB devices, Figure 1 displays the range of maximum allowable EIRP for the UWB signal structures that were classified within this study as pulse-like. Figure 3 presents the range of maximum allowable EIRP levels for those UWB waveforms that were classified as noise-like when considered in the analysis based on the operational scenarios. Figure 4 presents the range of maximum allowable EIRP levels for those UWB signals that were classified as CW-like in their effects on the GPS C/A-code receiver examined in this study. The labels on the y-axis in Figures 1 through 4 identify the various UWB signal structures in terms of PRF, percent gating, and type of modulation. For example, a UWB signal structure with a PRF of 100 kHz, 100% gating, and no modulation will have a y-axis label of: 100 kHz, 100%, None.

Figure 2 shows those pulse-like interference cases for which a range of EIRP values was not determined in the analysis. These cases involve UWB parameters that cause pulse-like interference in the operational scenarios that consider a single UWB device, but result in noise-like interference in the operational scenarios that consider multiple UWB devices. For the C/A code receiver architecture, there was only one scenario considered in the analysis (Single UWB Device Terrestrial Operational Scenario) that involved a single UWB device. Thus only a single EIRP value is shown in Figure 2.

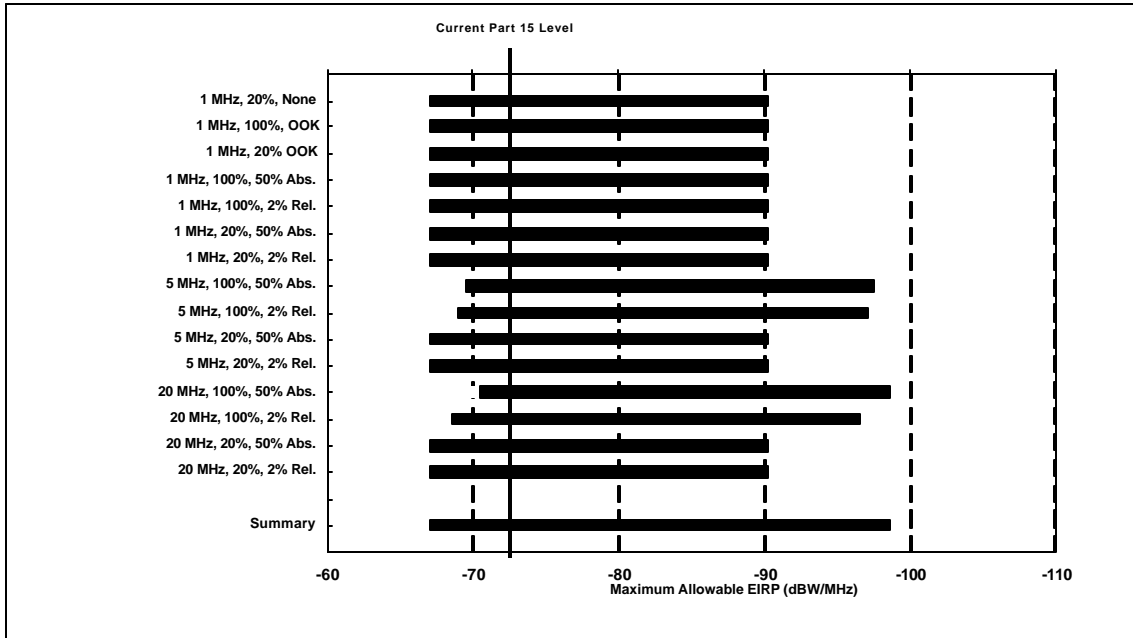




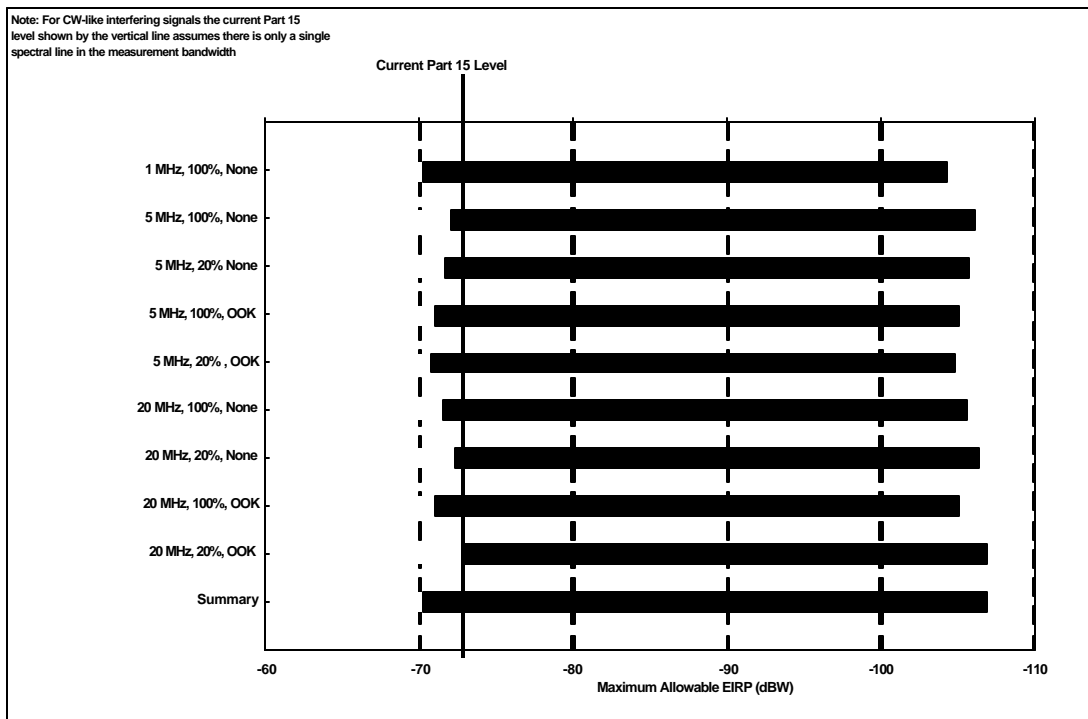
**Figure 1. Range of Maximum Allowable EIRP for Pulse-Like UWB Signal Structures for the C/A-Code Receiver Architecture (Multiple UWB Device Operational Scenario)**



**Figure 2. Maximum Allowable EIRP for Pulse-Like UWB Signal Structures for the C/A-Code Receiver Architecture (Single UWB Device Operational Scenario)**



**Figure 3. Range of Maximum Allowable EIRP for Noise-Like UWB Signal Structures for the C/A-Code Receiver Architecture (Multiple UWB Device Operational Scenario)**



**Figure 4. Range of Maximum Allowable EIRP for CW-Like UWB Signal Structures for the C/A-Code Receiver Architecture (Multiple UWB Device Operational Scenario)**

An examination of Figures 1 through 4 indicates that the maximum allowable EIRP levels required to satisfy the measured performance threshold of the GPS C/A-code receiver, across all of the operational scenarios, is a function of the PRF of the UWB signal. Figure 1 shows the maximum allowable EIRP levels corresponding to those UWB signal permutations with a PRF of 100 kHz. The EIRP level shown in this figure for the unmodulated, 100% gated UWB waveform was computed based on a measured break-lock threshold. For the remaining UWB signal permutations represented in the figure, neither a break-lock nor a reacquisition threshold could be measured for UWB power levels up to the maximum power available from the UWB signal generator. For these cases, the maximum UWB signal generator power level was used to compute the EIRP level. Thus, the reported EIRP level represents a lower limit for these cases. That is, the actual maximum allowable EIRP level may be higher than the level shown in the figure for these 100 kHz PRF UWB waveforms. From Figure 1, it can be observed that the maximum EIRP levels necessary to satisfy the measured performance threshold for the C/A-code GPS receiver over all of the operational scenarios considered in this study range from -73.2 to -26.5 dBW/MHz.

Figure 3 shows that the maximum allowable EIRP levels necessary to satisfy the measured performance thresholds over all of the operational scenarios considered in this study range from -98.6 to -67.0 dBW/MHz for those UWB signals employing PRFs of 1 MHz, 5 MHz, and 20 MHz, that are classified as noise-like in their interference effects to the GPS C/A-code receiver.

The data presented in Figure 4 shows that the maximum allowable EIRP levels range from -106.9 to -70.2 dBW over all of the operational scenarios considered for those UWB signals that are classified as CW-like in their interference effects on the GPS C/A-code receiver. These EIRP levels are based on the power in a single spectral line and in order to compare to the Part 15 level, it must be assumed that only a single spectral line appears in the measurement bandwidth.

Figures 5 and 6 present summary plots showing the maximum allowable EIRP calculated for the surveying operational scenarios assuming the use of the semi-codeless receiver architecture measured in this study. The analysis results are presented as a function of the various UWB signal structures examined. For the semi-codeless receiver architecture, the interference effects of all of the UWB signals examined are classified as either pulse-like or noise-like. Figure 5 shows that for those UWB signals examined with a PRF of 100 kHz, the calculated maximum allowable EIRP is above the current Part 15 emission level (i.e., no additional attenuation is necessary) with one exception: the 20% gated, 2% relative dithered signal.

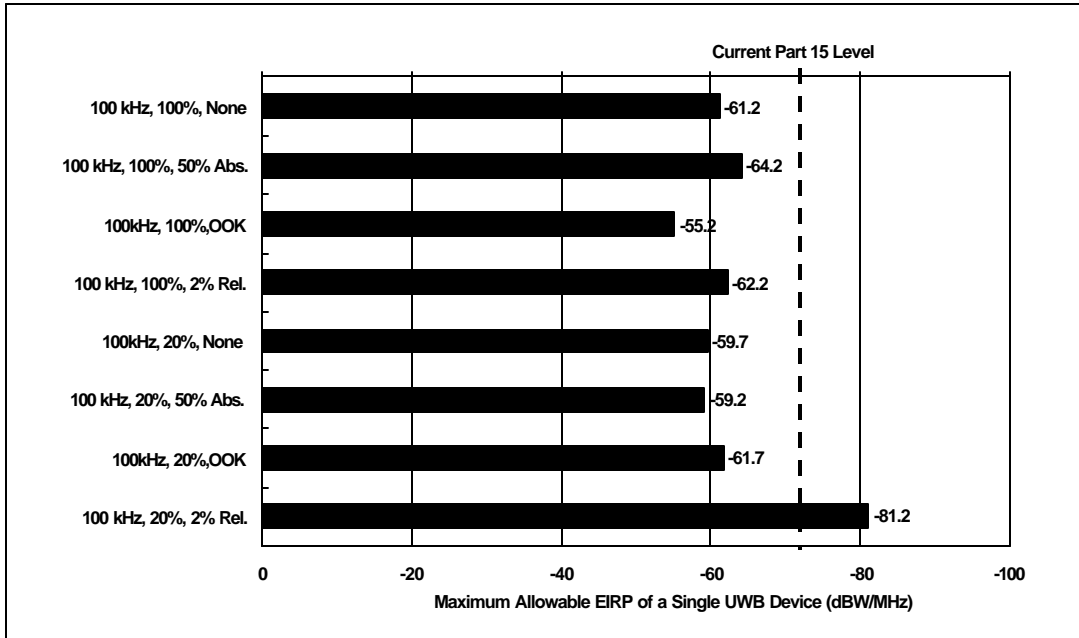


Figure 5. Maximum Allowable EIRP as a Function of UWB Signal Structure for the Semi-Codeless Receiver Architecture (Pulse-Like UWB Signals)

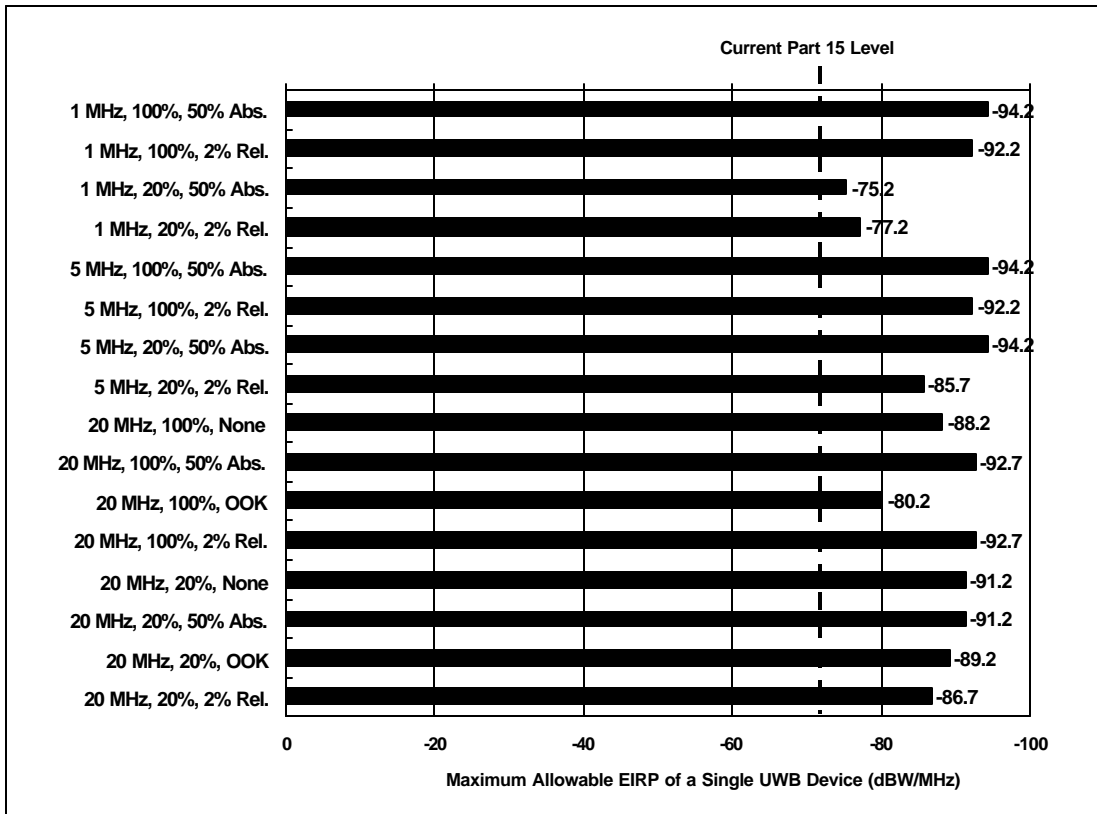


Figure 6. Maximum Allowable EIRP as a Function of UWB Signal Structure for the Semi-Codeless Receiver Architecture (Noise-Like UWB Signals)

Figure 6 shows that for the PRFs of 1 MHz, 5 MHz, and 20 MHz, those UWB signal structures that were classified as noise-like, the maximum allowable EIRP level must be as much as 23 dB below the current Part 15 level to satisfy the measured performance threshold of the semi-codeless GPS receiver in the applicable operational scenarios. The measurements of the semi-codeless receiver indicated a relative immunity to CW-like interference effects. This is because the semi-codeless receiver architecture uses the P-code signal which, because of its longer code length, has essentially no spectral lines.

## CONCLUSIONS

The data collected in this assessment demonstrates that when considered in potential interactions with GPS receivers used in applications represented by the operational scenarios considered in this study, some of the UWB signal permutations examined exceeded the measured GPS performance thresholds at EIRP levels well below the current Part 15 emission level. Likewise, other UWB signal permutations (e.g., the 100 kHz PRF UWB signals) only slightly exceeded, and in some cases did not exceed, the measured GPS performance thresholds when considered in potential interactions with GPS receivers defined by the operational scenarios considered as a part of this study.

The following general conclusions were drawn based on the findings of this study:

- 1) The GPS receiver performance thresholds measured within this study are consistent with the interference protection limits developed within national and international GPS study groups.
- 2) When multiple noise-like UWB signals with equivalent power levels at the GPS receiver input are considered, the effective aggregate signal level in the receiver IF bandwidth is determined by adding the average power of each of the UWB signals.
- 3) Within the limitations of this study (i.e., the available number of UWB signal generators), it was found that when multiple CW-like UWB signals are considered, the effective aggregate interference effect to a C/A-code GPS receiver is the same as that of a single CW-like signal. The interference mechanism is a result of the alignment of a UWB spectral line with a GPS C/A-code line.
- 4) The CW-like interference effect is not applicable to the semi-codeless receiver examined when operating in the dual frequency mode.
- 5) A GPS antenna does not offer any additional attenuation to that portion of a UWB signal within the GPS frequency band.
- 6) For those UWB signals examined with a PRF of 100 kHz, maximum permissible EIRP levels between -73.2 and -26.5 dBW/MHz are necessary to ensure EMC with the GPS applications defined by the operational scenarios considered within this study.

7) For those UWB signals examined with a PRF of 1 MHz, the maximum allowable EIRP levels necessary to achieve EMC with the GPS receiver applications considered in this study range from -70.2 to -104.3 dBW for the CW-like (unmodulated) UWB waveforms, and -57.6 to -91.6 dBW/MHz for the noise-like (modulated and/or dithered) UWB waveforms.

8) For those UWB signals examined with a PRF of 5 MHz, the maximum allowable EIRP levels necessary to ensure EMC with the GPS receiver applications considered in this study range from -70.7 to -106.1 dBW for the CW-like (non-dithered) UWB waveforms, and from -49.6 to -97.6 dBW/MHz for the noise-like (dithered) UWB waveforms.

9) For those UWB signals examined with a PRF of 20 MHz, the maximum allowable EIRP levels required to ensure EMC with all of the GPS receiver applications considered in this study range from -71.0 to -106.9 dBW for the CW-like (non-dithered) UWB waveforms, and from -60.0 to -98.6 dBW/MHz for the noise-like (dithered) UWB waveforms.

It must be noted that these results are applicable only to those UWB signal permutations examined within this study and to those applications of GPS that are defined by the operational scenarios presented for consideration herein.



# TABLE OF CONTENTS

EXECUTIVE SUMMARY .....	iii
TABLE OF CONTENTS .....	xxi
GLOSSARY OF ACRONYMS AND ABBREVIATIONS .....	xxiii
SECTION 1.0: INTRODUCTION .....	1-1
1.1 BACKGROUND .....	1-1
1.2 OBJECTIVE .....	1-4
1.3 APPROACH .....	1-4
1.3.1 Measurement Approach .....	1-4
1.3.2 Analysis Approach .....	1-9
SECTION 2.0: MEASUREMENT RESULTS .....	2-1
2.1 SUMMARY OF MEASUREMENT RESULTS .....	2-1
2.1.1 Single-Entry Conducted Measurements .....	2-1
2.1.2 Multiple Entry (Aggregate) Conducted Measurements .....	2-5
2.1.3 Radiated (Anechoic Chamber) Measurements .....	2-6
2.1.4 Amplitude Probability Distribution Measurements .....	2-7
2.2 COMPARISON OF MEASURED RESULTS WITH EXISTING GPS C/A-code INTERFERENCE LIMITS .....	2-8
2.2.1 Discussion of Existing GPS Interference Limits .....	2-8
2.2.2 Analysis of the Single-Entry Measured Data .....	2-9
2.2.2.1 Comparison of Single-Entry Measurements to Existing Threshold Limits .....	2-12
2.2.3 Analysis of Aggregate UWB Measurements .....	2-15
SECTION 3.0: ANALYSIS OVERVIEW .....	3-1
3.1 ANALYSIS DESCRIPTION .....	3-1
3.1.1 UWB Interference Threshold ( $I_T$ ) .....	3-1
3.1.2 GPS Receiver Antenna Gain ( $G_r$ ) .....	3-2
3.1.3 Radiowave Propagation Model ( $L_p$ ) .....	3-2
3.1.4 Multiple UWB Devices ( $L_{\text{multi}}$ ) .....	3-3



3.1.5 Interference Allotment ( $L_{\text{allot}}$ )	3-4
3.1.6 GPS Receiver Variation ( $L_{\text{man}}$ )	3-5
3.1.7 UWB Device Activity Factor ( $L_{\text{AF}}$ )	3-5
3.1.8 Building Attenuation ( $L_{\text{BA}}$ )	3-6
3.1.9 Aviation Safety Margin ( $L_{\text{safety}}$ )	3-6
3.1.10 GPS Receiver Architecture	3-6
<b>3.2 DEVELOPMENT OF THE GPS/UWB OPERATIONAL SCENARIOS</b>	<b>3-6</b>
3.2.1 Terrestrial Applications	3-8
3.2.1.1 Single UWB Device	3-8
3.2.1.2 Multiple UWB Device	3-8
3.2.2 Maritime Applications	3-10
3.2.3 Railway Applications	3-12
3.2.4 Surveying Applications	3-14
3.2.5 Aviation Applications	3-15
3.2.5.1 En-Route Navigation	3-16
3.2.5.2 Non-Precision Approach Landing	3-18
<b>3.3 ANALYSIS RESULTS</b>	<b>3-22</b>
3.3.1 Terrestrial Applications	3-29
3.3.2 Maritime Applications	3-35
3.3.3 Railway Applications	3-41
3.3.4 Surveying Applications	3-45
3.3.5 Aviation Applications	3-47
<b>SECTION 4.0: SUMMARY/CONCLUSIONS</b>	<b>4-1</b>
<b>4.1 SUMMARY OF MEASUREMENT FINDINGS</b>	<b>4-1</b>
4.1.1 C/A-code GPS Receiver	4-2
4.1.2 Semi-codeless GPS Receiver	4-8
4.1.3 Measurement Conclusions	4-11
<b>4.2 SUMMARY OF ANALYSIS FINDINGS</b>	<b>4-13</b>
<b>4.3 CONCLUSIONS</b>	<b>4-25</b>
<b>APPENDIX A: Derivation of Equations For Aggregate Effects of UWB Devices in the Non-Precision Approach Landing Operational Scenario</b>	<b>A-1</b>
<b>APPENDIX B: Results of Spreadsheet Analysis Program</b>	<b>B-1</b>

## GLOSSARY OF ACRONYMS AND ABBREVIATIONS

APD	Amplitude Probability Distribution
ARNS	Aeronautical Radionavigation Service
BL	Break-Lock
C/A	Coarse/Acquisition
$C/N_0$	Carrier-to-noise Power Density Ratio
CDMA	Code Division Multiple Access
CFR	Code of Federal Regulations
CMC	Code Minus Carrier
CW	Continuous Wave
dB	Decibels
dB <sub>i</sub>	Decibels relative to an isotropic antenna
dB <sub>c</sub>	Decibels relative to an isotropic circularly polarized antenna
dB <sub>m</sub>	Decibels relative to one milliwatt (equal to -30 dBW)
dBW	Decibels relative to one watt (equal to 30 dBm)
DGPS	Differential Global Positioning System
DNBL	Did Not Break lock
E-911	Enhanced-911
EIRP	Equivalent Isotropically Radiated Power
EMC	Electromagnetic Compatibility
ER	En-Route Navigation
FAA	Federal Aviation Administration
FCC	Federal Communications Commission
FTE	Flight Technical Error
GEO	Geostationary Earth Orbiting
GHz	Gigahertz
GPS	Global Positioning System
ICAO	International Civil Aviation Organization
IF	Intermediate Frequency
IGEB	Interagency GPS Executive Board
IRAC	Interdepartment Radio Advisory Committee
ITS	Institute for Telecommunication Sciences
ITU-R	International Telecommunication Union - Radiocommunication Sector
kHz	kilohertz
L1	GPS Link 1 (1575.42 MHz)
L2	GPS Link 2 (1227.60 MHz)
L5	GPS Link 5 (1176.45 MHz)
LAAS	Local Area Augmentation System
LNA	Low Noise Amplifier
LOS	Line-of-Sight

## **GLOSSARY OF ACRONYMS AND ABBREVIATIONS**

LR	Loss Ratio
MDH	Minimum Descent Height
MHz	Megahertz
ms	millisecond
MSS	Mobile Satellite Service
NASA	National Aeronautics and Space Administration
NOI	Notice Of Inquiry
NPA	Non-Precision Approach
NPRM	Notice of Proposed Rulemaking
NSE	Navigation System Error
NTIA	National Telecommunications and Information Administration
OOK	On-Off Keying
OSM	Office of Spectrum Management
PDOP	Position Dilution Of Precision
PRF	Pulse Repetition Frequency
PTC	Positive Train Control
RMS	Root-Mean-Square
RNSS	Radionavigation Satellite Service
RTCA	RTCA, Inc.
RQT	Reacquisition Time
TSE	Total System Error
TSO	Technical Standard Order
USCG	United States Coast Guard
UWB	Ultrawideband
WAAS	Wide Area Augmentation System

# SECTION 1.0 INTRODUCTION

## 1.1 BACKGROUND

The National Telecommunications and Information Administration (NTIA) is the Executive Branch agency principally responsible for developing and articulating domestic and international telecommunications policy. NTIA's responsibilities include establishing policies concerning spectrum assignments, allocation in use, and providing various departments and agencies with guidance to ensure that their conduct of telecommunication activities is consistent with these policies.<sup>7</sup> Accordingly, NTIA conducts technical studies and makes recommendations regarding telecommunication policies and presents Executive Branch views on telecommunications matters to the Congress, the Federal Communications Commission (FCC), and the public.

NTIA is responsible for managing the Federal Government's use of the radio frequency spectrum. The FCC is responsible for managing the spectrum used by the private sector, and state and local governments. In support of its responsibilities, the NTIA has undertaken numerous spectrum-related studies to assess spectrum utilization, examined the feasibility of reallocating spectrum used by the Federal Government or relocating Federal Government systems, identified existing or potential electromagnetic compatibility (EMC) problems between systems, provided recommendations for resolving any EMC conflicts, and recommended changes to promote efficient and effective use of the radio frequency spectrum and to improve Federal spectrum management procedures.

In February, 1998, U.S. Radar Inc., Time Domain Corporation, and Zircon Corporation, each petitioned the Commission for a waiver<sup>8</sup> of the Code of Federal Regulations, Title 47, Part 15 of the FCC rules.<sup>9</sup> The Part 15 rules authorize the operation of certain radio frequency devices without an individual station license from the FCC or the need for frequency coordination.<sup>10</sup> Within the Part 15 Rules, intentional radiators are defined as transmitters that are permitted to operate under a set of general

---

<sup>7</sup> NTIA, "Manual of Regulations and Procedures for Federal Radio Frequency Management", U.S. Department of Commerce, National Telecommunications and Information Administration (January 2000 Edition with revisions).

<sup>8</sup> *U.S. Radar Inc. Request for a Waiver of Part 15 for Ground Penetrating Radar* (Jan. 28, 1998), DA 98-221; *Time Domain Corporation Request for Limited Waiver of Part 15 of the Commission's Rules to Permit Authorization of Ultra-Wideband Time Modulating Technology* (Feb. 2, 1998), DA 98-222; and *Zircon Corporation Request for a Waiver of Part 15 for an Ultra-Wideband System* (April 14, 1998), DA 98-924.

<sup>9</sup> Title 47 Code of Federal Regulations § 15.1 (hereinafter "47 C.F.R.").

<sup>10</sup> 47 C.F.R. § 15.5. The primary operating conditions under Part 15 are that the operator must accept whatever interference is received and must correct whatever interference is caused. Should harmful interference occur, the operator is required to immediately correct the interference problem, even if correction of the problem requires ceasing operation of the Part 15 system causing the interference.

emission limits,<sup>11</sup> or in some cases under provisions that allow higher emission levels in certain frequency bands.<sup>12</sup> Intentional radiators generally are not permitted to operate in certain sensitive or safety-related frequency bands, designated as the restricted bands.<sup>13</sup> Because the waiver requests included Part 15 restricted frequency bands that are allocated for use by the U.S. Government, these requests were closely coordinated with NTIA. After discussions within the Interdepartment Radio Advisory Committee (IRAC), NTIA informed the FCC that the waivers could be granted with conditions that, among other things, required that: 1) all UWB operations be fully coordinated with the Frequency Assignment Subcommittee of the IRAC; 2) there will be limited distribution of the UWB equipment; and 3) records will be maintained for all users to whom the manufacturers sell, lease or otherwise distribute UWB equipment.<sup>14</sup> As a result of the conditions specified by NTIA, the three waiver requests were granted on June 25, 1999 by the Chief of the FCC's Office of Engineering and Technology.

In September 1998, the FCC issued a Notice of Inquiry (NOI) to investigate the authorization of Ultrawideband (UWB) transmission systems on an unlicensed basis under the Part 15 rules.<sup>15</sup> The responses to the NOI affirmed that recent advances in microcircuits and other technologies have resulted in the development of pulsed radar and communication systems with very narrow pulse widths in the time domain and very wide bandwidths in the frequency domain. These UWB transmission systems may be able to perform a number of useful radiocommunication functions that could make them very appealing for both commercial and government applications. UWB transmission systems can have very wide information bandwidths, are capable of accurately locating nearby objects, and can utilize signal processing technology with the UWB pulses to enable the devices to "see through objects" and to communicate in severe multipath environments.

The responses to the NOI also highlighted two primary obstacles that the current Part 15 Rules pose on the implementation of UWB transmission systems. First, the wide bandwidth that is intrinsic to the operation of UWB transmission systems can result in the transmission of the fundamental emission in restricted frequency bands, which is prohibited under the existing Part 15 Rules. Second, the current emission measurement procedures specified in the Part 15 Rules were developed for narrowband systems and therefore, may be inappropriate for, and may even pose unnecessary restrictions on UWB transmission systems, particularly impulse systems.

---

<sup>11</sup> 47 C.F.R. §15.209.

<sup>12</sup> 47 C.F.R. §§ 15.215-15.407. In some cases, operation at the higher emission levels within these designated frequency bands is limited to specific applications.

<sup>13</sup> 47 C.F.R. §15.205.

<sup>14</sup> Letter to Mr. Dale Hatfield, Chief, Office of Engineering and Technology, Federal Communications Commission from William T. Hatch, Acting Associate Administrator, National Telecommunications and Information Administration, Office of Spectrum Management (Jun. 15, 1999).

<sup>15</sup> *Revisions of Part 15 of the Commission's Rules Regarding Ultra-Wideband Transmission Systems*, Notice of Inquiry, ET Docket No. 98-153, 63 Fed. Reg 50184 (Sept. 21, 1998).

The FCC initiated a process to develop policy and regulatory decisions by releasing a Notice of Proposed Rulemaking (NPRM)<sup>16</sup> proposing regulations authorizing the operation of some UWB transmission systems on an unlicensed basis under the Part 15 Rules. The UWB NPRM contains a series of proposals and questions that can be grouped into the following broad categories: regulatory treatment, UWB definition, frequency bands of operation, further testing and analysis, emission limits, measurement procedures, prohibition against Class B damped wave emissions, and other matters. The FCC has specifically proposed that safety services, such as the Global Positioning System (GPS), be protected from harmful interference.<sup>17</sup>

GPS is an example of a critical radionavigation system that uses operating frequencies in the restricted frequency bands. GPS has become the preferred navigation system for aviation (en-route, precision and non-precision approach) and maritime operations. In order to meet the exacting standards required from a safety-of-life system, the U.S. Government has either developed or is developing augmentations to GPS for aviation, maritime, and land use. The Wide Area Augmentation System (WAAS) and the Local Area Augmentation System (LAAS) are under development to enhance aviation uses of GPS.<sup>18</sup> Differential GPS (DGPS) has been fielded to augment GPS for maritime use in intercoastal and inland waterways. GPS is also fast becoming an integral component of position determination applications such as Enhanced-911 (E-911) and personal location and medical tracking devices. The telecommunications, banking, and power distribution industries represent another sector that uses GPS for network synchronization timing. Moreover, GPS has proven to be a powerful enabling technology that has driven the creation of many new industries. GPS also provides the U.S. military and its allies with positioning, navigation, and timing capabilities that are critical to peacetime and wartime national and global security operations. Although these examples are not all inclusive, they illustrate the widespread use, and in many cases, dependence on the uninhibited availability of the GPS signals.<sup>19</sup>

Thus, NTIA accepted funding from the Interagency GPS Executive Board (IGEB) and the Federal Aviation Administration (FAA) to perform an assessment of the EMC between proposed UWB devices and GPS receivers.<sup>20</sup> The measurement component of this assessment was conducted by NTIA's Institute for Telecommunication Sciences (ITS) and the analyses portion was performed by the NTIA

---

<sup>16</sup> *Revisions of Part 15 of the Commission's Rules Regarding Ultra-Wideband Transmission Systems*, Notice of Proposed Rulemaking, ET Docket No. 98-153, FCC 00-163 (rel. May 11, 2000) (hereinafter "UWB NPRM").

<sup>17</sup> *Id.* at ¶ 23, 28, and 29.

<sup>18</sup> U.S. Department of Transportation and U.S. Department of Defense 1999 Federal Radionavigation Plan (Dec. 1999) at 1-11 (hereinafter "1999 FRP").

<sup>19</sup> GPS currently emits a civil signal centered at 1575.42 MHz (L1); however, an ongoing modernization effort will include new civil signals centered at 1227.60 MHz (L2) and 1176.45 MHz (L5).

<sup>20</sup> The UWB emissions considered in this assessment are limited to those using a burst of a series of impulse-like signals. However, there are several ways of defining UWB signals, one being emissions that have an instantaneous bandwidth of at least 25% of the center frequency of the device. There are also several ways of generating very wide signals, including the use of spread spectrum and frequency hopping techniques.

Office of Spectrum Management (OSM). This document provides a description of the methods used and the results obtained from these measurements and analyses. A separate report, prepared by ITS, that presents the measured data in post-processed format and provides details of the measurement procedures and equipment used to acquire the data, is available and is referenced throughout this report.<sup>21</sup>

## 1.2 OBJECTIVE

The objective of this assessment was to define the maximum allowable UWB equivalent isotropically radiated power (EIRP)<sup>22</sup> levels that can be tolerated by GPS receivers used within various operational applications without causing degradation to their operations. These EIRP levels will then be compared to the existing Part 15 emission limits<sup>23</sup> to assess the applicability of these limits to UWB devices.

## 1.3 APPROACH

A two-part approach consisting of both a measurement and an analysis component was adopted for this assessment. First, a measurement effort was undertaken to determine the interference threshold for different GPS receiver architectures to a set of UWB waveforms. Utilizing the measured GPS receiver interference threshold, analyses were performed for various operational scenarios to determine the maximum allowable UWB EIRP level, in the GPS frequency band, that can be tolerated by a GPS receiver before a performance degradation is realized.

### 1.3.1 Measurement Approach

The first activity associated with this project was the development of a plan to guide the measurement of GPS receiver susceptibility to UWB signals. In the formulation of a measurement plan, NTIA considered a number of factors including which GPS receivers to measure, what UWB signal parameters to examine, and what GPS receiver performance metrics and criteria to apply. Also as a part of the formulation of the measurement plan, a set of measurement procedures were developed with the intent that if followed, these procedures would lead to repeatable measurement results.

---

<sup>21</sup> NTIA Report 01-384 “Measurements to Determine Potential Interference to GPS Receivers from Ultrawideband Transmission Systems”, U.S. Department of Commerce, National Telecommunications and Information Administration, Institute for Telecommunication Sciences, (hereinafter “ITS Report”).

<sup>22</sup> The computation of EIRP is in terms of the average power of the UWB signal for all cases considered in this report. This average power is based on root-mean-square (RMS) voltage.

<sup>23</sup> The existing Part 15 measurement procedure uses an average logarithm detector process and is not equivalent to measurements using an RMS detector process. See NTIA Special Publication 01-43, “Assessment of Compatibility Between Ultrawideband Devices and Selected Federal Systems,” at 2-1 for discussion of the differences in measuring average power vs. log average power.

After the measurement plan was completed and made available to other Government agencies for review and comment, NTIA sought public comment in a notice published in the Federal Register.<sup>24</sup> The following seven parties submitted comments to the NTIA announcement;

- Air Transport Association
- ANRO Engineering, Inc.
- Multispectral Solutions, Inc.
- National Aeronautics and Space Administration (NASA) Glenn Research Center
- RAND Science and Technology Policy Institute
- Time Domain Corporation
- United States GPS Industry Council.

NTIA considered the comments, made appropriate changes to the measurement plan, and provided a response for each commenter for the public record. The initial measurement plan, the Federal Register notice, the public comments received, and the NTIA responses to the comments can be obtained from the NTIA website or directly from NTIA/OSM upon request.

One of the immediate difficulties encountered in establishing a methodology for measuring the impact of UWB emissions to GPS receivers was the lack of documented performance criteria for GPS receivers intended for applications other than aviation. After researching available technical standards and other open literature, a set of criteria that was not application specific was adopted for assessing the performance of the GPS receivers in this measurement effort. The two performance criteria examined were “break-lock” and “reacquisition.” Break-lock refers to the loss of signal lock between the GPS receiver and a GPS satellite. This condition occurs when an interfering signal reduces the carrier-to-noise density ( $C/N_0$ ) ratio (i.e., an increase in the undesired signal level,  $N_0$ , relative to the desired signal level,  $C$ ) to such an extent that the GPS receiver can no longer adequately determine the pseudorange (the initial/uncorrected measure of distance from a single GPS satellite to a receiver) for the given satellite signal. Within this measurement effort, the occurrence of a break-lock condition was as reported by the receiver. Depending on the receiver application, this condition could be a function of cycle slips, or a loss of carrier or phase lock. The reacquisition threshold refers to the UWB power level at which an abrupt increase from the nominal reacquisition time was observed.

To determine the impact on reacquisition time, the signal from the GPS satellite of interest was interrupted and a 50-meter step in pseudorange was introduced over a 10-second period. This was done to simulate a GPS-equipped vehicle passing behind a building or other obstacle in the satellite-to-receiver path, causing a temporary loss-of-lock between the GPS receiver and the satellite of interest. As the vehicle clears the obstacle and the satellite again becomes visible, the GPS receiver must be able to reacquire the lost satellite in the presence of UWB energy in a time consistent with that associated with no UWB energy present. In order to determine the maximum UWB level at which this can be

---

<sup>24</sup> National Telecommunications and Information Administration, Notice, Request for Comments on Global Positioning System/Ultrawideband Measurement Plan, Federal Register, Vol. 65, No. 157 (Aug. 14, 2000), at 49544.



accomplished, the UWB signal was reduced from the power level at which break-lock occurred until the receiver was able to reacquire the lost satellite in a time correspondent with the nominal receiver reacquisition time with no UWB signal present.

The UWB power level that results in receiver break-lock is not the preferred criterion for determining the interference threshold because it represents an extreme penalty to the performance of a GPS receiver. Thus, the interference threshold adopted for these measurements was the UWB signal level that resulted in a abrupt increase in the reacquisition time.<sup>25</sup> However, for some UWB signal permutations (e.g., those deemed to be CW-like signals), a statistical parameter such as reacquisition time could not be obtained due to limitations associated with the available test equipment (see discussion in Section 2.1.1 of this report). For these cases, break-lock was the only criterion available to perform an analysis of the measured results. Thus, for the subsequent evaluation of the measured data, the break-lock interference threshold was used in those cases where a reacquisition threshold could not be determined. This use of break-lock as the basis for establishing an interference threshold was done solely to facilitate the examination of potential trends in the data and should not be interpreted as an endorsement of the use of break-lock as an interference threshold on which to establish final rules for UWB operation.

The next challenge encountered was how to determine a representative sample of GPS receivers. Since GPS receivers are used in a myriad of applications, including navigation (aviation, space, maritime, rail, and vehicular), position determination (surveying, asset tracking, E-911), and timing (banking, power distribution, Internet synchronization), to name but a few, it is not feasible to attempt to measure a representative receiver from each possible application. Instead, NTIA decided to select candidate GPS receivers based upon the various available GPS receiver architectures. One receiver from each of three basic receiver architectures were identified for inclusion in the measurements: coarse acquisition (C/A)-code tracking receivers, which make up a significant share of the GPS receivers in use today, semi-codeless receivers used in low-dynamic applications requiring high precision (e.g., surveying and reference stations), and C/A-code tracking receivers employing multiple, narrowly-spaced correlators to enhance accuracy and mitigate the effects of multipath. These three GPS receiver architectures encompass most, if not all, of the existing civil GPS applications.<sup>26</sup> In order to address particular concerns related to an aviation use of GPS, a Technical Standard Order (TSO)-C129a compliant aviation receiver (as currently used in en-route and non-precision approach) was also included.<sup>27</sup> The assessment of potential UWB interference to aviation precision approach operations is currently being addressed in a Department of Transportation sponsored study and therefore was not considered in the scope of this effort.

---

<sup>25</sup> It should be noted that initial acquisition of a GPS satellite signal is an even more stringent performance criterion for GPS operations. However, this is an extremely difficult criteria to measure and is also highly dependent on manufacturer-specific receiver algorithms. Therefore, it was not considered feasible for use in this effort. A 6 dB factor is often used in GPS interference analyses to account for the greater sensitivity of initial satellite acquisition over the satellite tracking mode of operation.

<sup>26</sup> This effort did not consider the potential impact of UWB operations to military GPS receivers.

<sup>27</sup> Due to unanticipated delays in the execution of the measurement component of this study, the measured data for the narrowly-spaced GPS correlator receiver architecture and the TSO-C129a-compliant receiver were not included in this report. This data will be provided as an addendum to this report as it becomes available.

A third question to be addressed concerned defining the UWB signal(s) to be generated. Since there was little information revealed in the public record with regard to the proposed signal structure of UWB devices intending to operate as an overlay on the GPS band, no single UWB signal structure could be identified that would be representative of a typical UWB transmission system. Therefore, NTIA identified 32 distinct UWB signal structures as being representative of those expected to be used in UWB applications. Those UWB signal permutations identified for examination considered various pulse repetition frequencies (PRFs), modulation schemes, and gating percentages. Each combination of the UWB signal parameters shown in Table 1-1 was used to represent a distinct UWB signal permutation.

The PRF defines the number of pulses transmitted per unit time (one second). The PRF effects the spectral line magnitude and spacing, and the percentage of time that pulses are present.

**TABLE 1-1. UWB Permutations Considered in Measurements**

<b>UWB Parameter</b>	<b>Parameter Value</b>
PRF	0.1, 1, 5, and 20 MHz (nominal)
Modulation	None, OOK, 2% relative dither, 50% absolute dither
Gating	100% (always on), 20% (4 ms on, 16 ms off)

Gating refers to the process of distributing pulses in bursts by employing a programmed set of periods where the UWB transmitter is turned on or off for a period of pulses. For the measurements performed in this assessment, the gated UWB signal utilized a scheme where a burst of pulses lasting 4 milliseconds (ms) was followed by a 16 ms period when no pulses were transmitted. This is referred to as 20% gating, because the UWB pulses are transmitted 20% of the time. The signal permutations depicted within this report as 100% gating, define a signal where pulses are transmitted 100% of the time.

On-Off Keying (OOK) refers to the process of selectively turning off or eliminating individual pulses to represent data bits.

Dithering refers to the random or pseudo-random spacing of the pulses. Two forms of dithered UWB signals were considered in this effort. These are an absolute referenced dither, where the pulse period is varied in relation to the absolute clock, and a relative referenced dither, where the pulse spacing is varied relative to the previous pulse. The PRF of a relative dithered pulse train is equal to the reciprocal of the mean pulse period. Dithering of the pulses in the time domain spreads the spectral line content of a UWB signal in the frequency domain making the signal appear more noise-like.

The data collected from these measurements are applicable only to the UWB signal permutations that were considered in this assessment. No attempt should be made to extrapolate this data beyond those particular UWB parameters.

A GPS satellite simulator was used to provide simulated GPS signals from a four satellite constellation based on ephemeris data taken from an actual GPS constellation present on December 16, 1999. In the test constellation, one satellite was located at or near the zenith while the remaining three satellites were positioned near the horizon. The GPS receiver channel processing the signal from the near-zenith satellite was monitored for these measurements. This satellite was selected as the satellite to monitor because it has the least Doppler shift during the duration of the measurements. For the measurements performed on the C/A-code receiver, the power of the near-zenith satellite was set to the minimum specification level of -160 dBW.<sup>28</sup> The remaining three satellites were set to a power level 5 dB higher (-155 dBW). The higher power level was used for the remaining satellites so that a break-lock condition would not occur for these signals prior to break-lock of the monitored signal. The value of 5 dB was selected so that UWB power increments of 3 dB could be used to induce break-lock only on the receiver channel being monitored. For the measurements of the semi-codeless GPS receiver, which utilizes the GPS precision (P)-code, the GPS L1 and L2 power levels were set to -163 dBW. Except for the provision of an L2 signal and the power used, all other constellation parameters were consistent. All of the conducted measurements in this effort were performed over a 55-minute evolution of the constellation. The constellation was then reset for the subsequent test condition (e.g., another UWB signal permutation. More detailed information on this test constellation is presented in the ITS Report.<sup>29</sup>

A broadband noise signal was generated using a noise diode to represent the noise contribution from the cross-correlation phenomenon associated with the use of the relatively short Gold Codes in the GPS C/A signal. This cross-correlation noise arises because within a GPS receiver channel, the signals generated from GPS satellites other than the one being monitored by that channel, appear as undesired noise. This phenomenon is well documented in the open literature and the value used in this analysis is based upon work done within the International Telecommunication Union-Radiocommunication Sector (ITU-R).<sup>30</sup> This broadband noise was input to the GPS receiver at a level of -93 dBm/20 MHz (as derived for the minimum  $C/N_0$  of 34 dB-Hz identified in the ITU-R work) in the measurements of all of the GPS receivers examined with the exception of the semi-codeless receiver. Since this receiver utilizes the longer P-code GPS signals on L1 and L2, the cross-correlation noise attributed to the shorter Gold codes used with the C/A signal is not applicable.

For the single source interaction (i.e., a single UWB transmitter-to-GPS receiver) measurements, each UWB signal permutation was generated and combined with the simulated GPS satellite signals, and the broadband noise. The combined signal was injected into the GPS receiver at the antenna input. The UWB power level was increased until either the receiver broke lock with the satellite of interest or until the maximum available output power level from the UWB generator was reached. Plots of GPS receiver performance criteria (e.g., break-lock and reacquisition interference levels) were produced for each

---

<sup>28</sup> Global Positioning System Standard Positioning Service Signal Specification, 2<sup>nd</sup> Edition, GPS NAVSTAR, (June 2, 1995) at 18.

<sup>29</sup> ITS Report at 4-3.

<sup>30</sup> Recommendation ITU-R M.1477, Technical and Performance Characteristics of Current and Planned RNSS (Space-to-Earth) and ARNS Receivers to be Considered in Interference Studies in the Band 1559-1610 MHz, at section 3.2, (hereinafter "ITU-R M.1477").

UWB signal permutation measured. From these plots, the UWB average power level at which the performance criteria was determined and recorded. Data for additional GPS performance parameters (e.g., cycle slips and pseudorange error) were also recorded and are provided in the ITS Report.<sup>31</sup>

An additional set of measurements was performed to provide data that will indicate: 1) how individual UWB signals add to yield an effective aggregate power level, and 2) whether multiple UWB transmitting devices, each of which might be individually tolerated by a GPS receiver, will combine to create an aggregate interference level that will degrade the receiver performance. These aggregate measurements consisted of five measurement cases, each incorporating up to six UWB generators employing various combinations of UWB signal parameters (e.g., PRF, gating, and dithering).

In both the single-source and the aggregate interaction measurements described thus far, all signals were provided to the GPS receiver via a conducted path. Under actual operational conditions, both the UWB transmitting device and the GPS receiver will use antenna subsystems to transmit and receive radio frequency signals. Inherent in the conducted measurements is the assumption that the magnitude and phase distortion of the UWB signal is minimal over the GPS L1 band, for which the associated GPS antenna and preamplifier are designed to operate. Thus, there should essentially be no difference in the UWB signal as seen by the GPS receiver over the frequency range of interest, whether the signal is provided to the receiver through a conducted or radiated path. To verify these assumptions, a measurement was performed to determine that the signals passed through the two paths, conducted and radiated, are consistent. In all of the conducted measurements performed in this effort, the preamplifier recommended for use with the GPS receiver under test was modeled according to manufacturer specifications.

Both the initial measurement plan and the ITS Report contain more detail on these measurement procedures, including information on the measurement equipment used, test set-ups, and calibration procedures. These are available on the NTIA and ITS websites or directly from NTIA upon request.

### **1.3.2 Analysis Approach**

In order to calculate the maximum allowable EIRP, referenced to the output of a UWB transmit antenna, a typical source-path-receiver analysis must be performed. The basic parameters that must be defined for this type of analysis are the receiver interference threshold, the source output power and antenna gain, the propagation path between the transmitter and the receiver, and the antenna gain of the receiver in the direction of the source transmitter. The data obtained from the ITS measurements defines the interference threshold level at the input of the GPS receiver as a function of UWB signal structure (e.g., power, PRF, modulation scheme) for each of the GPS receiver architectures examined. The UWB output power and antenna gain combined define the EIRP, which is the variable to be determined from the analysis. In order to make reasonable assumptions regarding the remaining values needed for the analysis, information regarding how the transmitter and receiver can interact within their operating environment is necessary. Collectively, this information defines an operational scenario, which establishes how close the two systems may come to one another under actual operating conditions, and the likely orientation of the antennas. This information is then used to compute the propagation loss and the GPS

---

<sup>31</sup> ITS Report at Appendix F.

antenna gain in the direction of the UWB transmitting device. The operational scenario can also be used to determine the applicability of factors such as building attenuation, aggregate allowance, and safety margins.

NTIA hosted a series of public meetings to develop scenarios for GPS and envisioned UWB applications to define the applicable operational scenarios to be considered. The meetings were announced in the Federal Register on August 31, 2000.<sup>32</sup> Participation was encouraged within the UWB and GPS communities and among representatives of the interested Federal Agencies. Multispectral Solutions Inc., the National Oceanic and Atmospheric Administration/National Ocean Service/National Geodetic Survey, Time Domain Corporation, the United States Coast Guard (USCG), the U.S. GPS Industry Council, and NTIA submitted pertinent documents. Specific proposals for operational scenarios to be considered included GPS receivers used in the following applications: terrestrial<sup>33</sup> (e.g., public safety applications such as cellular phone embedded E-911 and emergency response vehicle navigation, geographic information systems, precision machine control, and general operations), maritime navigation (in constricted waterways, harbors, docking, and lock operations); railway operations (positive train control), surveying, and aviation (en-route navigation and non-precision approach). The input received at these meetings was used to develop the operational scenarios that were then used in the analyses documented in this report. These scenarios do not represent all possible applications of GPS, however, they do represent a reasonable bound on the parameters necessary to perform the broadly based analyses. For example, the separation distances represented in these scenarios range from a minimum of 2 meters for the embedded E-911 scenario, to a maximum of approximately 300 meters (1000 feet) for the en-route aviation scenario.

---

<sup>32</sup> National Telecommunications and Information Administration, Notice of Public Meeting to Develop Global Positioning System/Ultrawideband Operational Scenarios, Federal Register Vol. 65, No. 170 (Aug. 31, 2000) at 52989 (hereinafter “NTIA Notice”).

<sup>33</sup> Within the context of this report, terrestrial refers to land-based operations.

## **SECTION 2.0**

### **MEASUREMENT RESULTS**

#### **2.1 SUMMARY OF MEASUREMENT RESULTS**

The information presented in this section summarizes the data collected by ITS in the measurement component of this program, including single-entry results, multiple-entry (aggregate) results, radiated results, amplitude probability distribution (APD) results, and comparisons of the measurement results to existing interference limits. This data was extracted from the measurement plots documented in a report published by ITS<sup>34</sup>. There are two methods for performing radio interference measurements; those where the desired and undesired signals are conducted into the test receiver via a cable connection, and those where the signals are radiated into the test receiver via the propagation medium and antenna assembly. For this effort, conducted measurements were used to evaluate the performance of the GPS receivers.

##### **2.1.1 Single-Entry Conducted Measurements**

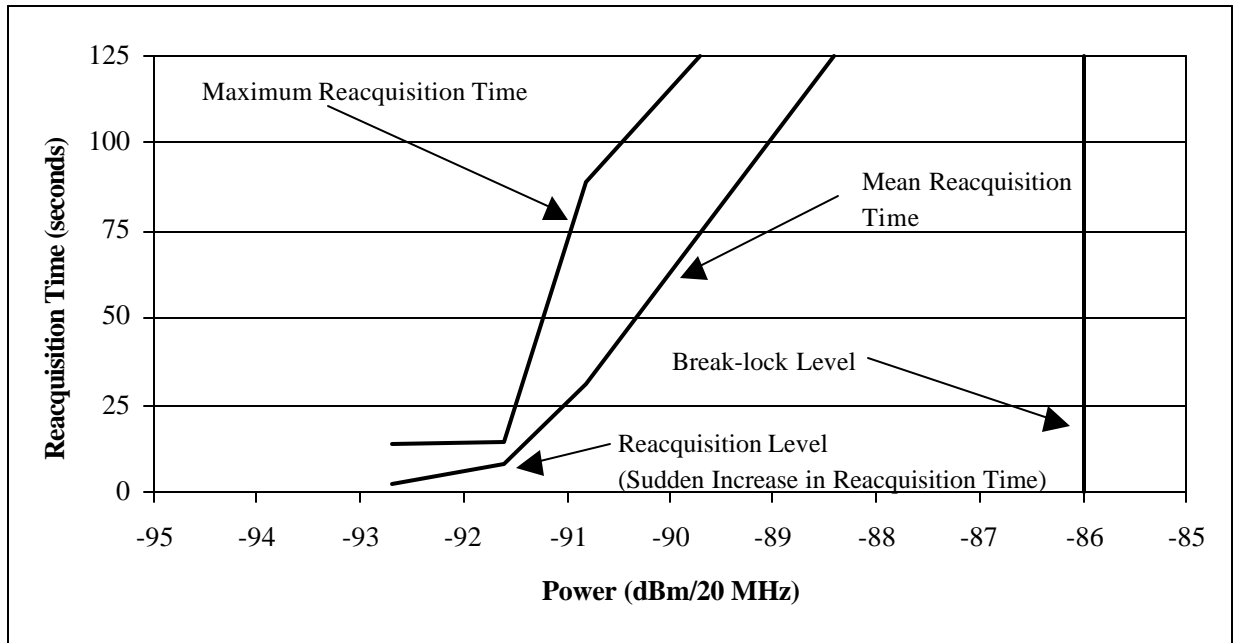
The data in Tables 2-1 and 2-2 summarize the receiver susceptibility measurements collected by ITS to be used in this assessment. The table entries correspond to the maximum tolerable UWB interference levels associated with the GPS receiver performance criteria adopted for this program. These points were extracted from the data curves presented in the ITS Report. Although each individual data plot is not reproduced within this report, a representative plot is provided in Figure 2-1 to illustrate how the data points associated with the GPS receiver performance criteria were obtained.

The break-lock and reacquisition threshold data points were taken from the ITS plots as illustrated below. In Figure 2-1, the break-lock level is represented by the heavy vertical line. This value was read directly from the scale on the horizontal axis, and has the units of dBm/20 MHz. There are two curves which represent reacquisition data. The lower curve is the mean reacquisition time measured over 10 trials. The upper curve is the maximum reacquisition time measured within these 10 samples. The interference threshold level for the reacquisition performance criterion was determined by locating the point on the lower curve (mean reacquisition time) corresponding to a sharp increase in the reacquisition time. The threshold level was then read directly from the scale on the horizontal axis, and has the units dBm/20 MHz. The power levels are average values for all single-entry UWB measurements except for the 20% gated signal<sup>35</sup> where the level represents the average power for the time when the signal is gated on. In a limited number of cases, the reacquisition threshold level that was determined by

---

<sup>34</sup>ITS Report at Appendix D.

<sup>35</sup>100% gating is a continuous uninterrupted PRF, 20% gating is a pulse train that is on for 4 ms in a 20 ms period.



**Figure 2-1. Illustration of Power Levels Resulting in Break-lock and Reacquisition**

these methods was at a higher interference signal level than the break-lock level. This is attributable to the statistical nature of these measurements where break-lock measurements involve a larger sample size than reacquisition. If a break-lock condition occurs at any time during the longer sampling period, break-lock is declared. In these instances (when the measured break-lock point was at a lower power than reacquisition), the reacquisition level threshold was set equal to the break-lock threshold.

The data used in this assessment, collected by ITS, is represented in Tables 2-1 and 2-2. These tables list the break-lock and reacquisition interference threshold levels for each UWB permutation measured. The tables are organized according to the GPS receiver architectures considered in the analysis.

For those UWB signal permutations that produced spectral lines within the GPS receiver passband, the measurement of a statistical parameter such as reacquisition time, or pseudorange error was not reliable or repeatable given the nature of the moving GPS constellation. To obtain 10 trials of reacquisition time can take as long as 20 minutes. During this time period, the statistics of GPS performance are non-stationary because the Doppler shift of the GPS C/A-Code lines causes them to, at some point, align with the UWB spectral lines. A GPS simulator with the capability of setting the Doppler shift to zero would facilitate collection of the reacquisition data for those UWB signal permutations containing spectral line components. The simulator used in this measurement effort did not have this capability. For this reason, entries in Tables 2-1 and 2-2 which contain an “x” indicate that the performance metric could not be measured with statistical reliability, and therefore is not reported.

**TABLE 2-1. Measurement Results for C/A-Code Receiver**

Interfering Signal Structure	Interference Susceptibility Levels* (dBm/20 MHz)	
	Break-Lock	Reacquisition
Broadband Noise	-87	-91.5
0.1 MHz PRF, No Mod, 100% Gate	-70	x
0.1 MHz PRF, No Mod, 20% Gate	[-57]	x
0.1 MHz PRF, OOK, 100% Gate	[-60]	x
0.1 MHz PRF, OOK, 20% Gate	[-59.5]	x
0.1 MHz PRF, 50% abs, 100% Gate	[-57]	[-57]
0.1 MHz PRF, 50% abs, 20% Gate	[-56.5]	[-56.5]
0.1 MHz PRF, 2% rel, 100% Gate	[-57]	[-57]
0.1 MHz PRF, 2% rel, 20% Gate	[-57]	[-57]
1 MHz PRF, No Mod, 100% Gate	-100.5	x
1 MHz PRF, No Mod, 20% Gate	[-47.5]	x
1 MHz PRF, OOK, 100% Gate	-78	x
1 MHz PRF, OOK, 20% Gate	[-51]	x
1 MHz PRF, 50% abs, 100% Gate	[-47]	-70
1 MHz PRF, 50% abs, 20% Gate	[-47.5]	[-47.5]
1 MHz PRF, 2% rel, 100% Gate	[-47.5]	-88
1 MHz PRF, 2% rel, 20% Gate	[-47.5]	-47
5 MHz PRF, No Mod, 100% Gate	-108.5	x
5 MHz PRF, No Mod, 20% Gate	-94.5	x
5 MHz PRF, OOK, 100% Gate	-104.5	x
5 MHz PRF, OOK, 20% Gate	-90.5	x
5 MHz PRF, 50% abs, 100% Gate	-86.5	-94
5 MHz PRF, 50% abs, 20% Gate	[-40]	-55
5 MHz PRF, 2% rel, 100% Gate	-85.5	-93.5
5 MHz PRF, 2% rel, 20% Gate	[-39]	[-39]
20 MHz PRF, No Mod, 100% Gate	-115	x
20 MHz PRF, No Mod, 20% Gate	-102	x
20 MHz PRF, OOK, 100% Gate	-111.5	x
20 MHz PRF, OOK, 20% Gate	-99.5	x
20 MHz PRF, 50% abs, 100% Gate	-89.5	-95
20 MHz PRF, 50% abs, 20% Gate	[-34]	-85
20 MHz PRF, 2% rel, 100% Gate	-87	-93
20 MHz PRF, 2% rel, 20% Gate	[-33]	-83

\* No measurable effect up to the power level shown in brackets.



**TABLE 2-2. Measurement Results for the Semi-Codeless Receiver (Interference only on L1 Frequency)**

Interfering Signal Structure	Interference Susceptibility Levels* (dBm/20 MHz)	
	Break-Lock	Reacquisition
Broadband Noise	-102.5	-107
0.1 MHz PRF, No Mod, 100% Gate	[-66]	-75
0.1 MHz PRF, No Mod, 20% Gate	[-66]	[-66]
0.1 MHz PRF, OOK, 100% Gate	[-68]	[-68]
0.1 MHz PRF, OOK, 20% Gate	[-68]	[-68]
0.1 MHz PRF, 50% abs, 100% Gate	-74	-78
0.1 MHz PRF, 50% abs, 20% Gate	[-66]	[-66]
0.1 MHz PRF, 2% rel, 100% Gate	-75	-76
0.1 MHz PRF, 2% rel, 20% Gate	[-66]	-88
1 MHz PRF, 50% abs, 100% Gate	-93.5	-108
1 MHz PRF, 50% abs, 20% Gate	-73	-82
1 MHz PRF, 2% rel, 100% Gate	-99.5	-106
1 MHz PRF, 2% rel, 20% Gate	-81	-84
5 MHz PRF, 50% abs, 100% Gate	-99	-108
5 MHz PRF, 50% abs, 20% Gate	-96.5	-101
5 MHz PRF, 2% rel, 100% Gate	-103	-106
5 MHz PRF, 2% rel, 20% Gate	-92.5	-92.5
20 MHz PRF, No Mod, 100% Gate	-102	x
20 MHz PRF, No Mod, 20% Gate	-98	x
20 MHz PRF, OOK, 100% Gate	-94	x
20 MHz PRF, OOK, 20% Gate	-96	x
20 MHz PRF, 50% abs, 100% Gate	-99.5	-106.5
20 MHz PRF, 50% abs, 20% Gate	-92	-98
20 MHz PRF, 2% rel, 100% Gate	-98.5	-106.5
20 MHz PRF, 2% rel, 20% Gate	-93.5	-93.5

\* No measurable effect up to the power level shown in brackets.

Other entries in these tables contain a power level in brackets. This indicates that for some of the UWB signal permutations, the total available power from the UWB simulator was used without resulting in a loss of lock or an impact on reacquisition time for the GPS receiver and the satellite of interest.

## 2.1.2 Multiple-Entry (Aggregate) Conducted Measurements

As part of this measurement and analysis effort, a limited number of test cases were measured where the interference signal was a composite representing several UWB emitters operating simultaneously. Table 2-3 provides a list of the UWB parameters considered in each aggregate measurement. During these tests, there was no attempt to synchronize the transmissions of the UWB signal generators. NTIA is not aware of any applications that uses synchronized UWB transmissions. For example, through-the-wall imaging radars transmit in bursts and wireless local area networks are packet radios that essentially transmit in bursts. Although the measurement configuration may be used to synchronize the transmissions from multiple UWB sources, NTIA believes that such a configuration is not of practical interest or utility. That is, the UWB system hardware cost and/or data overhead to synchronize emissions would seem to be prohibitive for what is envisioned for a low cost system. Furthermore, for the pulses from several synchronized UWB transmission systems to overlap at the GPS receiver would require the distance to each UWB transmission system to be the same to within less than 1 meter (assuming a 1 nanosecond pulse width). For the aggregate measurements, the unit-under-test was the C/A-code receiver.

**TABLE 2-3. UWB Signal Parameters for Aggregate Measurements**

Measurement Case	UWB Signal Parameters Measure combined interference power at receiver input over a range to obtain break-lock and reacquisition data
I	PRF: 10 MHz (#1); 10 MHz (#2); 10 MHz (#3); 10 MHz (#4); 10 MHz (#5); 10 MHz (#6) Gating: 100 % Dithering: 2% Rel.
II	PRF: 10 MHz (#1); 10 MHz (#2); 10 MHz (#3); 10 MHz (#4); 10 MHz (#5); 10 MHz (#6) Gating: 20 % Dithering: 2% Rel.
III	PRF: 10 MHz (#1); 10 MHz (#2); 3 MHz (#3); 3 MHz (#4); 3 MHz (#5); 3 MHz (#6) Gating: 100 % (#1, #2, #3); 20% (#4, #5, #6) Dithering: No dithering (#1, #2, #3), 2% Rel. (#4, #5, #6)
IV	PRF: 3 MHz (#1); 3 MHz (#2); 3 MHz (#3); 3 MHz (#4); 3 MHz (#5); 3 MHz (#6) Gating: 20 % Dithering: No dithering (#1, #2, #3, #4), 2% Rel. (#5, #6)
V	PRF: 1 MHz (#1); 1 MHz (#2); 1 MHz (#3); 1 MHz (#4); 1MHz (#5); 1MHz (#6) Gating: 100 % Dithering: 2% Rel. Perform tests with only UWB signal generator #1on; with #1 and #2 on; with #1, #2 and #3 on and with all four on; etc. until all six generators are on.

In Measurement Cases I through IV, the power level of each UWB signal generator (with the signal parameters of Table 2-3) was set such that they were equal at the input to the UWB signal combiner.

The power level associated with each gated signal (to determine equality at the input to the UWB signal combiner) was the average power during the time the UWB signal was gated on. The aggregate UWB power (all signal sources turned on) into the GPS receiver was then controlled by attenuators after the output of the UWB signal combiner. The aggregate UWB power shown on the measured data plots is the total power without gating of any UWB signal. The exact PRF of each UWB signal generator that caused CW-like interference was adjusted to assure that: 1) one spectral line from each generator was within several kHz of the GPS L1 center frequency of 1575.42 MHz, and 2) the spectral lines, from multiple sources, were not coincident in frequency. With the above conditions, the aggregate UWB signal, noise and GPS signals were input to the GPS receiver. The aggregate signal power level was varied and the GPS receiver performance was measured.

In Measurement Case V, the power level of each UWB signal was set such that they were equal at the input of the UWB signal combiner when turned on. However, the first set of GPS receiver performance tests within Measurement Case V was performed with only a single UWB signal generator turned on. The test was repeated with two UWB signal generators turned on. Tests were also performed with three, four, five and then six UWB signal generators turned on.

The break-lock and reacquisition threshold levels were extracted from the ITS plots for aggregate measurements.<sup>36</sup> The methods used to determine these thresholds were the same as those outlined in Section 2-1. The break-lock and reacquisition threshold levels are listed in Table 2-4.

### **2.1.3 Radiated (Anechoic Chamber) Measurements**

To examine the applicability of the conducted measurements, the effects of the GPS antenna on the radiated signals within the frequency band of interest were measured. Measurements were performed wherein the UWB signal was radiated and received within an anechoic chamber. This characterized the effects of the GPS antenna on the UWB signal. These measurements were performed in an anechoic chamber to prevent outside interference sources from affecting the results. The test set-up is shown in Figure 2-2.

A comparison between the radiated and conducted path measurements of the APD and the analyses of the magnitude distortion and the variations in the group delay presented in the ITS Report<sup>37</sup> indicate that the GPS antenna gain in the direction of the interference source is the only parameter that needs to be considered in the source-path-receiver analyses. The GPS antenna does not cause any additional effects to the portion of the UWB signal within the GPS operating band.

---

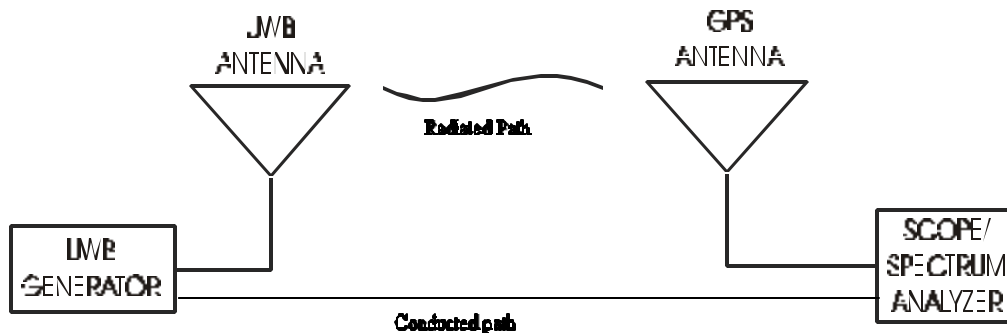
<sup>36</sup> ITS Report at Appendix F.

<sup>37</sup> ITS Report at 44.

**TABLE 2-4. Results of Aggregate Measurements for C/A-Code Receiver**

Measurement Case	Interference Thresholds* (dBm/20 MHz) (combined interference power at receiver input as measured without gating)	
	Break-Lock	Reacquisition
I	-87.5	-94.5
II	-79.5	-86
III	-109	-109
IV	-88	-90
V (One UWB Generator)	[-48]	-88
V (Two UWB Generators)	[-62.5]	-93
V (Three UWB Generators)	-85	-93
V (Four UWB Generators)	-83.5	-93
V (Five UWB Generators)	-84	-94
V (Six UWB Generators)	-83.5	-93

\* No measurable effect up to the power level shown in brackets.



**Figure 2-2. Radiated Measurement Test Setup.**

### 2.1.4 Amplitude Probability Distribution Measurements

The APD is used in radio engineering to describe signal amplitude statistics. The APD contains information on the percentage of time the envelope of UWB signals in a specific intermediate frequency (IF) bandwidth exceeds various amplitudes. Statistics such as percentiles, deciles and the median can be read directly from the APD. Other parameters such as average power can also be computed from

the APD. The APDs can also be used in determining the interference effect characteristics of UWB signal permutations (e.g., CW-like, noise-like, or pulse-like).

In this effort, APDs were measured in 3 MHz and 20 MHz bandwidths (typical of GPS receiver IF bandwidths), at the GPS L1 center frequency of 1575.42 MHz, for each UWB signal permutation considered. A discussion on APDs, as well as the APDs measured as a part of this program are presented in the ITS Report.<sup>38</sup>

## **2.2 COMPARISON OF MEASURED RESULTS WITH EXISTING GPS C/A-CODE INTERFERENCE LIMITS**

### **2.2.1 Discussion of Existing GPS Interference Limits**

NTIA compared the measured results with existing interference limits applicable to C/A-code GPS receivers. This was done to 1) determine whether the measured interference thresholds were significantly different than existing protection requirements and 2) assess the consistency of the measured data.

The existing interference limits for C/A-code GPS receivers have been developed by a body of GPS experts within the RTCA and the ITU-R. The RTCA limits consider interference signals that are characterized as pulsed, CW, and broadband noise. The ITU-R Recommendation considers CW and broadband noise-like interference signals. For the case of in-band pulsed interference, the RTCA derived limit is a peak power of +20 dBm for pulse widths less than 1 ms and pulse duty cycles less than 10%. For the in-band CW interference case, both the RTCA and the ITU-R interference limits are defined as -150.5 dBW for GPS receivers operating in the tracking mode. For in-band broadband noise interference, both the RTCA and the ITU-R limits are -140.5 dBW/MHz for GPS receivers when operating in the tracking mode.

The RTCA and the ITU-R interference limits are referenced to the input of the GPS receiver and are based on a minimum available GPS C/A-code signal level of -134.5 dBm (-130 dBm minimum guaranteed signal level into a -4.5 dBic antenna),<sup>39</sup> also referenced to the input of the GPS receiver. Since the measurements reported in this effort are based on a GPS signal level of -130 dBm (i.e., GPS antenna gain assumed to be 0 dBic), it was necessary to adjust the interference data by -4.5 dB to account for the difference in desired signal level. The adjustment in this case takes into account that the performance of GPS is dependent on the carrier to noise (including receiver thermal noise) ratio. That

---

<sup>38</sup> ITS Report at Appendix C.

<sup>39</sup> Document Number RTCA/DO-229B, Minimum Operational Performance Standard for GPS/ Wide Area Augmentation System Airborne Equipment (January.1996) at 38 (hereinafter DO-229B); ITU-R M.1477 at ANNEX 1, Section 3-2.

is, over the range of parameters of interest, with CW-like and noise-like interference, performance is not a function of absolute power levels. Thus, if the desired GPS signal is decreased by 4.5 dB, then the effective interference needs to be decreased by 4.5 dB to maintain the same GPS performance for comparison with existing limits.

### **2.2.2 Analysis of the Single-Entry Measured Data**

The measured UWB interference effect on the GPS receiver for each UWB permutation considered was classified as either pulse-like, CW-like, or noise-like. The pulse-like category is primarily developed as a result of the bandlimiting filter in the GPS receiver. That is, the bandwidth of the UWB signal is typically several orders of magnitude wider than the bandlimiting filters in the GPS receiver. Thus, the pulse shape and bandwidth of the bandlimited pulse corresponds to the impulse response of the receiver filter. Pulses are independent when the filter bandwidth is greater than the pulse repetition rate. That is consecutive independent pulses, at the output of the bandlimiting filter, do not overlap in the time domain. Pulses that were independent without dithering can overlap when dithering is introduced. To remain independent, the minimum pulse repetition period of the dithered signal must be greater than the duration of the filter impulse response. If the bandlimited pulse is independent and of sufficient amplitude, it will saturate one or more elements in the receiver during the pulse period. This will result in “holes” in the GPS signal. If these “holes” are relatively short and of a relatively low duty cycle, they will not seriously degrade the GPS performance. An increase in the amplitude of the pulse will not significantly increase the width of the “holes” and thus the interference effect is somewhat independent of UWB signal strength as long as the amplitude is below the receiver peak pulse power limit (. +20 dBm). These effects are represented in the RTCA interference limits for pulsed interference.

Typical GPS receivers have an IF bandwidth on the order of several MHz to 20 MHz, therefore, the pulses for most of the 0.1 MHz and 1.0 MHz PRF UWB signal permutations are independent and can be classified as pulse-like. An examination of the data in Table 2-1 reveals only three UWB signal permutations utilizing a 0.1 or 1.0 MHz PRF where a break-lock condition could be measured. These three specific permutations are defined by 0.1 MHz PRF, no modulation, 100% gating; 1 MHz PRF, no modulation, 100% gating; and 1 MHz PRF, OOK, 100% gating. For two of these permutations (0.1 MHz PRF, no modulation, 100% gating and the 1 MHz PRF, OOK, 100% gating), the break-lock interference levels are relatively high (-70 and -78 dBm/20 MHz). An examination of the APDs for these permutations showed signals of a relatively high level for 10% or less of the time. Thus, these two permutations were also considered to represent pulse-like interference conditions as indicated in Table 2-5. The inability to measure a break-lock condition within the available power of the UWB generator, and the PRFs involved, was judged to be indicative of signals that appear pulse-like in the GPS receiver. Four other signal permutations were also judged to be indicative of pulse-like interference signals. These four permutations all employed dithering and gating. For all four of these permutations, break-lock could not be attained with the maximum signal power available from the UWB generator.

The UWB signal permutations that had a pulse-like interference effect are shown in Table 2-5. A direct comparison with the RTCA limit could not be made since break-lock was not attainable within the output signal power limits of the measurement set-up. Furthermore, a continued increase in signal power for these permutations could result in damage to the front-end of the receivers via burn-out, and thus was not pursued as a part of this effort. However, it can be seen from the last data point obtained (i.e., the maximum available signal power) that for a UWB signal that causes pulse-like interference, the GPS receiver performance was fairly robust.

The next category of UWB permutations examined were those that appeared to cause CW-like interference. The decision to categorize a UWB permutation as CW-like was primarily based on whether the UWB signal showed dominant lines in the spectra. This CW-like characteristic was then confirmed by examining the APD for that signal permutation. An additional factor in determining whether a particular UWB permutation demonstrated CW-like characteristics was the fact that a reacquisition measurement could not be reliably performed due to the non-stationary statistics for this GPS performance parameter when CW interference occurred. The obvious case of UWB signals that are CW-like in their impact to GPS receivers are those UWB signal permutations with constant PRFs (i.e., employing no modulation). The spectral lines produced in the emissions of such UWB permutations with PRFs of 1 MHz or greater, appear as CW interference to a C/A-code tracking GPS receiver. If the spectral lines contained in the UWB signal coincide with a dominant spectral line of the GPS C/A-code signal, the GPS receiver performance can be degraded at a low UWB power level. As a result of the Doppler effects introduced by the motion of the GPS satellites, the C/A-code lines will shift in frequency thus increasing the probability of a spectral line contained within the UWB signal coinciding with a dominant C/A-code line. Based on the analytical work performed within the RTCA and the ITU-R, GPS receivers are most susceptible to CW interference. Other UWB signals with non-dithered PRFs of 5 and 20 MHz employing OOK modulation<sup>40</sup>, gating (20%)<sup>41</sup>, or combinations of OOK modulation and gating will also demonstrate strong CW components. The existence of CW lines for these cases is indicated in the ITS report. The UWB signal permutations considered in this effort that were determined to cause CW-like interference are shown in Table 2-5.

The remaining UWB signal permutations considered in this effort (5 and 20 MHz, 100% gated, with 2% relative or 50% absolute dithering) were determined to cause noise-like interference based on examination of the associated APDs. These are shown as the last of the entries in Table 2-5.

---

<sup>40</sup>ITS Report at 59.

<sup>41</sup>ITS Report at 13.

**TABLE 2-5. Categorization of UWB Signal Permutations**

Interfering Signal Structure	Category Of Interfering Signal Effect	Adjusted Interference Threshold
0.1 MHz PRF, No Mod, 100% Gate	Pulse-Like	Direct Comparison to existing GPS protection levels cannot be made due to the fact that the measurement setup could not attain a power level of +20 dBm. The results do, however, indicate a trend of relative GPS robustness when subjected to low duty cycle pulsed interference consistent with the existing RTCA interference threshold.
0.1 MHz PRF, No Mod, 20% Gate	Pulse-Like	
0.1 MHz PRF, OOK, 100% Gate	Pulse-Like	
0.1 MHz PRF, OOK, 20% Gate	Pulse-Like	
0.1 MHz PRF, 50% abs, 100% Gate	Pulse-Like	
0.1 MHz PRF, 50% abs, 20% Gate	Pulse-Like	
0.1 MHz PRF, 2% rel, 100% Gate	Pulse-Like	
0.1 MHz PRF, 2% rel, 20% Gate	Pulse-Like	
1 MHz PRF, No Mod, 20% Gate	Pulse-Like	
1 MHz PRF, OOK, 100% Gate	Pulse-Like	
1 MHz PRF, OOK, 20% Gate	Pulse-Like	
1 MHz PRF, 50% abs, 100% Gate	Pulse-Like	
1 MHz PRF, 50% abs, 20% Gate	Pulse-Like	
1 MHz PRF, 2% rel, 100% Gate	Pulse-Like	
1 MHz PRF, 2% rel, 20% Gate	Pulse-Like	
5 MHz PRF, 50% abs, 20% Gate	Pulse-Like	
5 MHz PRF, 2% rel, 20% Gate	Pulse-Like	
20 MHz PRF, 50% abs, 20% Gate	Pulse-Like	
20 MHz PRF, 2% rel, 20% Gate	Pulse-Like	
1 MHz PRF, No Mod, 100% Gate	CW-Like	
5 MHz PRF, No Mod, 100% Gate	CW-Like	-150.0 dBW
5 MHz PRF, No Mod, 20% Gate	CW-Like	-150.0 dBW
5 MHz PRF, OOK, 100% Gate	CW-Like	-149.0 dBW
5 MHz PRF, OOK, 20% Gate	CW-Like	-149.0 dBW
20 MHz PRF, No Mod, 100% Gate	CW-Like	-149.5 dBW
20 MHz PRF, No Mod, 20% Gate	CW-Like	-150.5 dBW
20 MHz PRF, OOK, 100% Gate	CW-Like	-149.0 dBW
20 MHz PRF, OOK, 20% Gate	CW-Like	-151.0 dBW
5 MHz PRF, 50% abs, 100% Gate	Noise-Like	-141.5 dBW/MHz
5 MHz PRF, 2% rel, 100% Gate	Noise-Like	-141.0 dBW/MHz
20 MHz PRF, 50% abs, 100% Gate	Noise-Like	-142.5 dBW/MHz
20 MHz PRF, 2% rel, 100% Gate	Noise-Like	-140.5 dBW/MHz



### 2.2.2.1 Comparison of Single-Entry Measurements to Existing Threshold Limits

For the UWB permutations that cause pulse-like interference effects, a direct comparison to the existing limit of +20 dBm (pulse peak power) could not be made due to the fact that the measurement set-up could not attain a power level of +20 dBm. However, at the maximum power available from the UWB generator, the GPS receiver could not be made to lose lock with the satellite of interest. For the two remaining cases, the power required to cause a break-lock was relatively high. These results indicate a trend of relative GPS robustness when subjected to low duty cycle pulsed interference consistent with the existing RTCA interference threshold.<sup>42</sup>

For the case of CW-like interference, the power contained in the UWB spectral line within the GPS passband must be determined. As a result of the non-stationary characteristic of the statistical measures of GPS receiver performance when the CW interfering signal is aligned (or nearly aligned) in frequency with a dominant C/A-code spectral line, it was not possible to obtain a reliable reacquisition. Thus, for the purposes of comparison to the existing interference criteria, the break-lock interference threshold was used for the CW-like signal cases.

An example of the calculation used to adjust the measured data for UWB signal permutations that cause a CW-like interference effect to the basis represented in the development of the existing interference limits is shown in Tables 2-6 through 2-9. The implicit assumption in these comparisons is that the interference mechanism involves one UWB spectral line interfering with a dominant C/A-code spectral line. Table 2-6 shows the necessary adjustments to the measured thresholds for the CW-like UWB signal permutations utilizing a constant PRF (i.e., no modulation).

The adjustment necessary for comparison between the measured interference threshold and the existing protection limits for a UWB signal that causes a CW-like interference effect utilizing OOK modulation includes a 3 dB factor for the division of power between discrete spectral lines and continuous spectrum.<sup>43</sup> Table 2-7 shows the necessary adjustments to the measured threshold.

The adjustments necessary for a UWB signal permutation (causing a CW-like interference effect) utilizing gating include additional factors to account for 1) the average power over the gating period since the power reported in the measurements is the power during the gate-on period ( $10\log 0.2 = -7$  dB for 20% gating), 2) the number of major spectral lines contained in the measurement bandwidth ( $-10\log 5$  for a 5 MHz PRF), and 3) an adjustment for the spectral spreading due to gating. When gating is applied to signals with spectral lines, the result is the single line of the non-gated case (major spectral lines) are spread into a number of lines where the spacing between the lines is equal to the reciprocal of the gating period (e.g., 1/20 ms or

---

<sup>42</sup> DO-229B at 186.

<sup>43</sup> ITS Report at Appendix B.

**TABLE 2-6. Adjustments to Measured Level for a Constant PRF UWB Signal**

UWB Signal Permutation	5 MHz PRF, No Mod, 100% Gating
Measured Break-Lock Level	-108.5 dBm/20 MHz
Individual Power Adjustments	
Conversion to dBW	-30 dB
Correction for GPS signal level (i.e., from -130 dBm used in measurements to -134.5 dBm used in threshold development)	-4.5 dB
Power in a single spectral line (-10log 5, where 5 represents the number of lines contained in the 20 MHz measurement bandwidth)	-7 dB
Total Power Adjustment	-41.5 dB
Adjusted Break-Lock Level (-108.5 dBm - 41.5 dB)	-150.0 dBW
Interference Threshold Developed in RTCA and ITU-R	-150.5 dBW

**TABLE 2-7. Adjustments to Measured Level for a OOK Modulated UWB Signal**

UWB Signal Permutation	20 MHz PRF, OOK, 100% Gating
Measured Break-Lock Level	-111.5 dBm/20 MHz
Individual Power Adjustments	
Division of power between discrete spectral lines and continuous spectrum <sup>44</sup>	-3 dB
Conversion to dBW	-30 dB
Correction for GPS signal level (i.e., from -130 dBm used in measurements to -134.5 dBm used in threshold development)	-4.5 dB
Power in a single spectral line (-10log 1, where 1 represents the number of lines contained in the 20 MHz measurement bandwidth)	0 dB
Total Power Adjustment	-37.5 dB
Adjusted Break-Lock Level (-111.5 dBm - 37.5 dB)	-149.0 dBW
Interference Threshold Developed in RTCA and ITU-R	-150.5 dBW

---

<sup>44</sup> ITS Report at 59.

spectral lines are convolved with a  $\text{sinc}^2$  function<sup>45</sup> obtained from the gating envelope.<sup>46</sup> The 50 Hz for the 20% gating considered in this study) and the null spacing of the  $\text{sinc}^2$  function is equal to two times the reciprocal of the gated-on time (e.g., 2/4 ms or 500 Hz in this study). The half-power bandwidth of this function is 250 Hz and will contain a significant majority of the total power of the  $\text{sinc}^2$  spectrum. Therefore, for a CW-like UWB signal permutation using 20% gating, the half-power bandwidth (250 Hz) will contain 5 spectral lines at 50 Hz spacing. Thus, the adjustment necessary to account for this distribution of power among the spectral lines is  $-10\log(5) = -7$  dB in 250 Hz. The adjustments for a CW-like UWB signal permutation using 20% gating are shown in Table 2-8.

The adjustments necessary for a UWB signal permutation (causing a CW-like interference effect) using an OOK modulation and 20% gating are a combination of the adjustments discussed in the previous two examples (Tables 2-7 and 2-8). These required adjustments for a UWB signal permutation employing OOK modulation and 20% gating are summarized below in Table 2-9.

In order to compare UWB signal permutations (causing a noise-like interference effect) to the existing interference thresholds, the adjustments to the measured data include: 1) conversion of power from dBm to dBW, 2) an adjustment to convert from a 20 MHz measurement bandwidth to a 1 MHz reference bandwidth, and 3) a correction of 4.5 dB to adjust for the difference in GPS signal levels. The measured GPS parameter used as the basis of comparison is the reacquisition level. The adjustments to the measured data for the broadband noise measurement are illustrated in Table 2-10. The same process was used to adjust the noise-like UWB signal permutations for comparison to the existing interference limits.

The results shown in these tables and summarized in the last column of Table 2-5 show consistent agreement with the existing protection limits developed within RTCA and ITU-R of -140.5 dBW/MHz for noise-like interfering signals and -150.5 dBW for CW-like interfering signals. The maximum difference between the levels measured in this effort and the existing protection limits is 2 dB. This indicates that the measured data set is consistent within the range of variations of UWB signal permutations measured. It is noted that for the CW-like UWB signal permutations considered in this effort, this comparison is based on break-lock levels rather than reacquisition levels (due to difficulties discussed previously in this section). However, if it is assumed that the reacquisition level is on the order of 2-3 dB lower than the break-lock level, then the consistency between the measured data and the existing protection limits remains strong.

---

<sup>45</sup>The sinc function is defined as  $\text{sinc}(\text{argument}) = \text{Sin}(\text{argument})/\text{argument}$ .

<sup>46</sup> ITS Report at 13.

**TABLE 2-8. Adjustments to Measured Level for a 20% Gated UWB Signal**

UWB Signal Permutation:	5 MHz PRF, No Mod, 20% Gate
Measured Break-Lock Level:	-94.5 dBm/20 MHz
Individual Power Adjustments	
Conversion to dBW	-30 dB
Correction for GPS signal level (i.e., from -130 dBm used in measurements to -134.5 dBm used in threshold development)	-4.5 dB
Power in a single spectral line (-10log 5, where 5 represents the number of lines contained in the 20 MHz measurement bandwidth)	-7 dB
Adjustment for gate-on time relative to total time (-10 log 5)	-7 dB
Adjustment to compute power in a single spectral line that is modulated by a sinc <sup>2</sup> function by the gating period	-7 dB
Total Power Adjustment	-55.5 dB
Adjusted Break-Lock Level (-94.5 dBm - 55.5 dB)	-150.0 dBW
Interference Threshold Developed in RTCA and ITU-R	-150.5 dBW

### 2.2.3 Analyses of Aggregate UWB Measurements

The results of Case I show that, if the individual interference signals cause an effect that is noise-like, the aggregate signal will be noise-like with the power of the effective aggregate interfering signal determined by summing the average power of the individual UWB signals. For Case I, the measured break-lock level was -87.5 dBm/20 MHz and the reacquisition threshold was -94.5 dBm/20 MHz. These values can also be adjusted for comparison to existing noise-like interference protection levels using the procedures of Section 2.2.2. The adjusted reacquisition threshold is -142 dBW/MHz; that compares to the existing limit of -140.5 dBW/MHz.

The results of the Case II measurements show that an aggregate signal can “fill in” the off periods of the low duty cycle interference at the IF filter output. This results in the UWB aggregate signal of Case II showing an interference effect that is noise-like. The single signal effect for the UWB parameters used was pulse-like. The power level of the effective aggregate interfering signal is determined by summing the average power of the individual UWB signals. For Case II, the measured break-lock level was -79.5 dBm/20 MHz and the reacquisition threshold was -86 dBm/20 MHz. These values can also be adjusted for comparison to existing noise-like interference protection levels. The adjusted, measured reacquisition threshold (including a 7dB factor to compute the average power for a signal with 20% gating) is -140.5 dBW/MHz; that compares to the existing limit for noise-like interference of -140.5 dBW/MHz.

**TABLE 2-9. Adjustments to Measured Level for a UWB Signal Employing OOK Modulation and 20% Gating**

UWB Signal Permutation	5 MHz PRF, OOK, 20% Gate
Measured Break-Lock Level	-90.5 dBm/20 MHz
Individual Power Adjustments	
Conversion to dBW	-30 dB
Correction for GPS signal level (i.e., from -130 dBm used in measurements to -134.5 dBm used in threshold development)	-4.5 dB
Division of power between discrete spectral lines and continuous spectrum for OOK	-3 dB
Power in a single spectral line (-10log 5, where 5 represents the number of lines contained in the 20 MHz measurement bandwidth)	-7 dB
Adjustment for gate-on time relative to total time (-10 log 5)	-7 dB
Adjustment to compute power in a single spectral line that is modulated by a sinc <sup>2</sup> function by the gating period	-7 dB
Total Power Adjustment	-58.5 dB
Adjusted Break-Lock Level (-90.5 dBm - 58.5 dB)	-149.0 dBW
Interference Threshold Developed in RTCA and ITU-R	-150.5 dBW

**TABLE 2-10. Adjustments to Measured Level for a Noise-Like Signal**

Signal Permutation	Baseline Noise
Measured Reacquisition	-91.5 dBm/20 MHz
Individual Power Adjustment	
Conversion to dBW	-30 dB
Correction for GPS signal level (i.e., from -130 dBm used in measurements to -134.5 dBm used in threshold development)	-4.5 dB
Conversion from 20 MHz measurement bandwidth to 1 MHz reference bandwidth	-13 dB
Total Power Adjustment	-47.5 dB
Adjusted Reacquisition Level (-91.5 dBm - 47.5 dB)	-139.0 dBW/MHz
Interference Threshold Developed in RTCA and ITU-R	-140.5 dBW/MHz

The results of the Case III aggregate measurements showed that line spectra, if produced by one or more sources, can be the dominant cause of interference to GPS. The interference effect in Case III is CW-like; this is further indicated by the CW lines appearing in the measurements of the aggregate spectrum for Case III.<sup>47</sup> Because the interference is attributable to a single interfering CW signal that is coincident with a dominant GPS C/A-code line the aggregate signals do not add to determine the effective interfering signal power. Of course, in the case of an aggregate interfering signal that is a composite of several sources having line spectra, the increased number of potential interfering lines would be expected to increase the probability of coincidence with a dominant C/A-code line. It is also expected that, if there were a very large number (central limit theorem) of signals with line spectra, one would see an aggregate signal that would produce a noise-like effect. For this Case, the measured break-lock level was -109 dBm/20 MHz and the reacquisition threshold was -109 dBm/20 MHz. These values can be adjusted for comparison to existing CW-like interference protection levels. The adjustments consider that one of the lines from a 10 MHz PRF UWB signal will be the cause of the interference and that three of the aggregated signals were gated on 20% of the time. The adjusted reacquisition threshold is -154.1 dBW; that compares to the existing limit of -150.5 dBW.

The results of the Case IV measurements again showed that line spectra are the dominant cause of interference. The interference effect in Case IV is CW-like; this is further indicated by the CW lines appearing in the measurements of the aggregate spectrum for Case IV<sup>13</sup>. Because the interference is attributable to a single interfering CW signal that is coincident with a dominant C/A-code line, the aggregate signals do not add to determine the effective interfering signal power. Of course, in the case of an aggregate interfering signal that is a composite of several signals having line spectra, the increased number of potential interfering lines would be expected to increase the probability of coincidence with a dominant C/A-code line. It is also expected that, if there were a very large number (central limit theorem) of signals with line spectra, one would see an aggregate signal that would produce a noise-like effect. For this case, the measured break-lock level was -88 dBm/20 MHz and the reacquisition threshold was -90 dBm/20 MHz. These values can be adjusted for comparison to existing CW-like interference protection levels. The adjustment considers that one of the lines from the 3 MHz PRF signals will be dominant. The adjusted reacquisition threshold is -148 dBW; that compares to the existing limit of -150.5 dBW.

The results of the Case V measurements also show that an aggregate signal condition can “fill in” the off-periods of the low duty cycle pulses at the output of the GPS receiver IF filter. This is further illustrated by the step-by-step introduction of individual UWB signals to form the aggregate signal. This results in the interference mechanism changing from pulse-like (in the single and two signal case) to noise-like (in the three through six UWB signal aggregate cases). The noise-like characteristic is also caused by the dithering of the UWB signal as opposed to a constant PRF that would result in a CW-like effect. In this case, the effective aggregate interference level is the sum of the individual UWB signal average power levels. The measured break-lock level was -83.5 dBm/20 MHz and the

---

<sup>47</sup>ITS Report at Figure 6.3.2.1.

reacquisition threshold was -93 dBm/20 MHz for the final test where the aggregate consisted of six individual signals. These values can be adjusted for comparison with existing RTCA and ITU-R protection limits. This would yield an adjusted measured value of -140.5 dBW/MHz that compares to the existing limit for noise-like interference of -140.5 dBW/MHz.

In summary, the aggregate measurements are in keeping with what one would expect. They show the “fill in” effect that causes a transition from pulse-like to noise-like interference. The data shows that when the aggregate interference is noise-like, the effective aggregate interference power level is the sum of the individual UWB signal average power levels. When the aggregate interference, associated with a somewhat limited number of UWB sources, is CW-like, the measured results show the interference threshold power to be that associated with the power of a single spectral line. Although these results are for a somewhat limited number of UWB signals, they are directly applicable to most of the scenarios considered in this study. These aggregate measurements also show results that are consistent with existing GPS interference protection limits. The comparison of the adjusted aggregate interference reacquisition thresholds with the existing limits of RTCA and ITU-R are summarized in Table 2-11.

**Table 2-11. Comparison of Adjusted Aggregate Interference Thresholds with Existing Limits**

<b>Aggregate Interference Measurement Case</b>	<b>Category of Aggregate Interfering Signal Effect</b>	<b>Adjusted Reacquisition Threshold</b>	<b>Existing Limits</b>
I	Noise-Like	-142 dBW/MHz	-140.5 dBW/MHz
II	Noise-Like	-140.5 dBW/MHz	-140.5 dBW/MHz
III	CW-Like	-154.1 dBW	-150.5 dBW
IV	CW-Like	-148 dBW	-150.5 dBW
V (6 UWB Generators)	Noise-Like	-140.5 dBW/MHz	-140.5 dBW/MHz

## SECTION 3.0 ANALYSIS OVERVIEW

### 3.1 ANALYSIS DESCRIPTION

The measurements performed by the ITS define the interference threshold of a UWB device as a function of the UWB signal parameters (e.g., power, PRF, gating, modulation). The interference threshold is measured at the input of the GPS receiver and is used in the analysis for each specific GPS/UWB operational scenario to calculate the maximum allowable emission level at the output of the UWB device antenna. The following paragraphs describe the analysis method used.

The maximum allowable emission level from the UWB device is based on an EIRP limit. The EIRP is the power supplied to the antenna of the UWB device multiplied by the relative antenna gain of the UWB device in the direction of the GPS receiver. The maximum allowable EIRP is computed using the following equation:

$$\text{EIRP}_{\text{max}} = I_T - G_r + L_p - L_{\text{mult}} - L_{\text{allot}} - L_{\text{man}} + L_{\text{AF}} + L_{\text{BA}} - L_{\text{safety}} \quad (1)$$

where:

- $\text{EIRP}_{\text{max}}$  is the maximum allowable EIRP of the UWB device (dBW or dBW/MHz);
- $I_T$  is the interference threshold of the UWB signal at the input of the GPS receiver (dBW or dBW/MHz);
- $G_r$  is the gain of the GPS antenna in the direction of the UWB device (dBi);
- $L_p$  is the radiowave propagation loss (dB);
- $L_{\text{mult}}$  is the factor to account for multiple UWB devices (dB);
- $L_{\text{allot}}$  is the factor for interference allotment (dB);
- $L_{\text{man}}$  is the factor to account for manufacturer variations in GPS receivers (dB);
- $L_{\text{AF}}$  is the activity factor of the UWB device (dB);
- $L_{\text{BA}}$  is the building attenuation loss (dB);
- $L_{\text{safety}}$  is the aviation safety margin (dB).

The following paragraphs explain each of the technical factors used in the analysis.

#### 3.1.1 UWB Interference Threshold ( $I_T$ )

The UWB interference threshold referenced to the input of the GPS receiver is obtained from the single source interference susceptibility measurements performed by ITS as discussed in Section 2.1.1 (Tables 2-1 and 2-2). Adjustments are made to the measured interference susceptibility levels to compute the UWB interference threshold. As discussed in Section 3.3 (Tables 3-13 and 3-14), the adjustments made to the measured interference susceptibility levels are based on the individual UWB signal structure.



### 3.1.2 GPS Receiver Antenna Gain ( $G_r$ )

The GPS antenna gain model used in this analysis is provided in Table 3-1. The antenna gain used is based on the position of the UWB device with respect to the GPS antenna and is determined from the GPS/UWB operational scenario under consideration.

**TABLE 3-1. GPS Antenna Gain Based on UWB Device Position With Respect to GPS Antenna**

Off-axis Angle (Measured with Respect to the Horizon)	GPS Antenna Gain (dBi)
-90 degrees to -10 degrees	-4.5
-10 degrees to 10 degrees	0
10 degrees to 90 degrees	3

The off-axis angle measured with respect to the horizon is computed by:

$$\theta = \tan^{-1} [(h_{UWB} - h_{GPS})/D] \quad (2)$$

where:

- $\theta$  is the angle measured with respect to the horizon (degrees);
- $h_{UWB}$  is the UWB device antenna height (m);
- $h_{GPS}$  is the GPS receiver antenna height (m);
- $D$  is the horizontal separation between the GPS receiver and UWB device (m).

### 3.1.3 Radiowave Propagation Model ( $L_p$ )

The radiowave propagation loss is computed using the minimum distance separation between the GPS receiver and the UWB device as defined by the GPS/UWB operational scenario. The radiowave propagation model used also depends on the GPS/UWB operational scenario. By definition, “free-space” assumes that there is a line-of-sight (LOS) path between the UWB device and the GPS receiver. The radiowave propagation model described by the free-space loss equation is :

$$L_p = 20 \text{ Log } F + 20 \text{ Log } D_{\min} - 27.55 \quad (3)$$

where:

- $L_p$  is the free-space propagation loss (dB);
- $F$  is the frequency (MHz);
- $D_{\min}$  is the minimum distance separation between the GPS receiver and UWB device (m).

As a result of antenna heights and terrain conditions, free-space conditions may not exist. There is a phenomenon referred to as the propagation loss breakpoint, which consists of a change in the slope of the propagation loss with distance at a radial distance from the transmitter. It is caused by the reflection of the transmitted signal by the ground. This multipath signal interferes with the direct path signal and usually occurs only in areas with clear LOS and ground reflection paths.

For the frequency range of interest, the propagation loss changes by 20 dB/decade (i.e., free-space loss) close to the transmitter, and by 40 dB/decade after the propagation loss breakpoint occurs. The propagation loss breakpoint radius from the transmitter,  $R_b$ , is calculated using the formula <sup>48</sup>:

$$R_b = 2.3 \times 10^{-6} F (h_t h_r) \quad (4)$$

where:

$R_b$  is the propagation loss breakpoint radius (mi);

F is the frequency (MHz);

$h_t$  is the UWB device antenna height (ft);

$h_r$  is the GPS receiver antenna height (ft).

When the minimum distance separation between the UWB device and the GPS receiver is less than  $R_b$ , the free-space propagation model should be used. When the minimum distance separation between the UWB device and the GPS receiver is greater than  $R_b$ , a propagation model that takes into account non-LOS conditions should be used.

### 3.1.4 Multiple UWB Devices ( $L_{mult}$ )

The GPS/UWB operational scenario determines whether single or multiple UWB devices should be considered. The factor for multiple UWB devices was obtained from the multiple source (aggregate) measurements performed by ITS. Section 2.1.2 of this report, discusses the multiple UWB devices measurement results. Based on the multiple source measurements, the factor to be included in the analysis for multiple UWB devices will depend on whether the interference effect has been characterized as being pulse-like, CW-like, or noise-like. The exception is the en-route navigation operational scenario, where it is assumed that there are a large enough number of UWB devices, such that independent of the individual UWB signal parameters, the aggregate effect causes noise-like interference.

As discussed in Section 2.2.3, signals that were characterized as being pulse-like for single UWB device interactions were characterized as being noise-like when multiple UWB devices are considered. The occurrence of the transition from pulse-like to noise-like interference was verified in Measurement

---

<sup>48</sup> E. N. Singer, *Land Mobile Radio Systems* (Second Edition) at 194.

Case V. The number of UWB devices required for this transition to occur depends on the PRF. For the 1 MHz PRF signals, the measurements show that three signals are required for the transition to occur. In the case of the 100 kHz PRF signals, the number of UWB devices necessary for the transition to occur will be much larger than the number of UWB devices under consideration in the operational scenarios. Based on the measurement results, a factor for multiple UWB devices is not included in this analysis for signal permutations that have been characterized as causing pulse-like interference with a PRF of 100 kHz.

The interference effect for UWB signals that have been characterized as being CW-like is attributed to the single interfering CW line that is coincident with a dominant C/A-code line. This was discussed in Section 2.2.3, and confirmed in Measurement Cases III and IV. Multiple UWB signals that are characterized as causing CW-like interference, do not add to determine the effective interfering signal power. A large number of UWB devices producing spectral lines would be necessary before there is a transition to a noise-like interference effect. This transition from CW-like to noise-like will not occur with the number of UWB devices under consideration in the operational scenarios. Based on the measurement results, a factor for multiple UWB devices is not included in this analysis for UWB signal permutations that have been characterized as causing CW-like interference.

UWB signals permutations with PRFs of 1 MHz, 5 MHz, and 20 MHz that have been characterized as being pulse-like, will transition to noise-like interference as the number of UWB devices is increased. This is discussed in Section 2.2.3 and verified in Measurement Case V. For these UWB signals permutations, a factor of  $10 \log$  (number of UWB devices) is included in the analysis.

As discussed in Section 2.2.3, and verified in Measurement Case I and II, if the individual signals cause an interference effect that is noise-like, the interference effect of the multiple noise-like signals is noise-like. Based on the measurement results, for UWB signal permutations that have been characterized as causing noise-like interference, a factor of  $10 \log$  (number of UWB devices) is included in the analysis.

### **3.1.5 Interference Allotment ( $L_{\text{allot}}$ )**

Several potential sources of interference to GPS receivers have been identified. These include but are not limited to: 1) adjacent band interference from mobile satellite service (MSS) handsets; 2) harmonics from television transmitters; 3) adjacent band interference from super geostationary earth-orbiting (super GEO) satellite transmitters<sup>49</sup>; 4) spurious emissions from 700 MHz public safety base, mobile, and portable transmitters; and 5) spurious emissions including harmonics from 700 MHz commercial base, mobile, and portable transmitters. Multiple sources of interference, which might

---

<sup>49</sup> Super GEOs are geostationary earth orbiting satellites that are designed to employ a high transmit power to communicate with mobile handsets.

individually be tolerated by a GPS receiver, may combine to create an aggregate interference level (e.g., noise and emissions) that could prevent the reliable reception of the GPS signal. In the GPS/UWB operational scenario, a percentage of the total allotment for all interfering sources will be attributed specifically to UWB devices.

In this analysis the percentage of the total interference allotment that is attributed to UWB devices is dependent on the minimum distance separation between the GPS receiver and the UWB device. The minimum distance separation is established by each operational scenario. For operational scenarios where the minimum distance separation is small (e.g., on the order of several meters), the UWB device is expected to be the dominant source of interference, and 100% of the total interference is allotted to UWB devices. For operational scenarios where a larger distance separation exists, there is a greater likelihood that other interfering sources will contribute to the total interference level at the GPS receiver. In these operational scenarios, 50% of the total interference is allotted to UWB devices. That is, one half of the total allowable interference is allotted to UWB and the other half is allotted to all other interfering sources combined. For the aviation operational scenarios, larger geographic areas are visible to a GPS receiver onboard an aircraft. This larger field of view will increase the number of interfering sources that can contribute to the total interference level at the receiver. In the aviation operational scenarios, 10% of the total interference is allotted to UWB devices. The factor for UWB device interference allotment is computed from  $10 \text{ Log} (\text{UWB interference allotment ratio})$ . For example, if the UWB device interference allotment is 50% ( a ratio of 0.5), a 3 dB factor is included in the analysis.

### **3.1.6 GPS Receiver Variation ( $L_{\text{man}}$ )**

The ITS measurement effort did not consider multiple samples of each model of GPS receiver. Therefore, it is not possible to determine if there is a statistical variation in the performance of GPS receivers. As an estimate, a 3 dB factor has been included to take into account likely variations among GPS receivers of the same model as well as variations in GPS receivers from different manufacturers.

### **3.1.7 UWB Device Activity Factor ( $L_{\text{AF}}$ )**

The activity factor represents the percentage of time that the UWB device is actually transmitting. For example, a UWB device that is transmitting continuously will have an activity factor of 100%, no matter what PRF, modulation, or gating percentage is employed. The activity factor is only applicable when multiple UWB devices are considered in the GPS/UWB operational scenario. Some UWB devices are expected to have inherently low activity factors such as those that are manually activated with a trigger or “deadman” switch. Others will likely have high activity factors such as a UWB local area network. Since It was not possible to estimate practical values of activity factors for each potential UWB application, an activity factor of 100% (a ratio of 1) was used in all of the operational scenarios considered in this analysis. Thus, the activity factor used is set equal to 0 dB (i.e.,  $10 \text{ Log} (1)$ ).

### **3.1.8 Building Attenuation ( $L_{BA}$ )**

For GPS/UWB operational scenarios that consider the use of UWB devices operating indoors a building attenuation factor is included. ITS has conducted building attenuation loss measurements at 912, 1920, and 5990 MHz.<sup>50</sup> The measurements were performed for different buildings representing typical residential and high rise office construction. Based on the results of these measurements, whenever the UWB device is considered to be operating indoors an average building attenuation of 9 dB is used.

### **3.1.9 Aviation Safety Margin ( $L_{safety}$ )**

When the GPS/UWB operational scenario involves aviation applications using GPS (e.g., en-route navigation and non-precision approach landing) a safety margin is appropriate. The aviation safety margin takes into account sources of radio-frequency interference that are real but not quantifiable (e.g., multipath). A safety margin of 6 dB is included for GPS receivers used in aviation applications.<sup>51</sup>

### **3.1.10 GPS Receiver Architecture**

Interference susceptibility measurements were performed on the C/A-code and semi-codeless GPS receiver architectures. The GPS receiver architecture examined in the analysis are different depending upon the operational scenario under consideration. In those where the GPS receivers are used in moving vehicles (terrestrial, maritime, and railway), the C/A-code architecture was used. In the surveying operational scenario, where the GPS receiver is not moving (or moving very slowly), the semi-codeless receiver architecture was used. For the en-route navigation and non-precision approach landing operational scenarios a TSO-C129a compliant GPS receiver is used.<sup>52</sup>

## **3.2 DEVELOPMENT OF THE GPS/UWB OPERATIONAL SCENARIOS**

As discussed in the previous section, the measurements of the maximum tolerable interference threshold at the input to the GPS receiver is used in this analysis to compute the maximum allowable

---

<sup>50</sup> National Telecommunications and Information Administration, Institute for Telecommunication Sciences, NTIA Report 95-325, Building Penetration Measurements From Low-height Base Stations at 912, 1920, and 5990 MHz, at 43.

<sup>51</sup> ITU-R M.1477 at Annex 5.

<sup>52</sup> The measurement results of the C/A-code TSO-C129a receiver are not available at this time. The analysis results that are presented are based on the measurements for the non-aviation C/A-code receiver. Although not aviation certified, it is representative of the architecture used by aviation in these applications. When data on the TSO-C-129a receiver is available, the results of the analysis may be revised.

EIRP of the UWB device. The operational scenario is necessary to relate the interference level at the input of the GPS receiver to the output of the UWB device. The GPS/UWB operational scenarios establish: the minimum distance separation between the GPS receiver and the UWB device; the appropriate antenna coupling; the applicable radio wave propagation model; whether single or multiple UWB devices should be considered; and any other scenario specific factors (e.g., building attenuation and aviation safety margin).

On August 31, 2000, NTIA published a Notice in the Federal Register announcing a series of public meetings to be held to gather information to be used by NTIA in developing the operational scenarios for assessing the potential interference to GPS receivers from UWB devices.<sup>53</sup> Meetings were held on September 7 and 27, and December 7 giving the Federal agencies and the public opportunities to present documents related to the development of GPS/UWB operational scenarios. Documents were submitted by: Multispectral Solutions Inc., the National Oceanic and Atmospheric Administration/National Ocean Science/National Geodetic Survey, NTIA, Time Domain Corporation, the USCG, and the U.S. GPS Industry Council. The specific proposals for operational scenarios included GPS receivers used in the following applications<sup>54</sup>:

- Public Safety (E-911 embedded in a cellular phone);
- Public Safety (emergency response vehicles);
- Geographic Information Systems;
- Precision Machine Control;
- Maritime (constricted waterway navigation, harbor navigation, docking and lock operations);
- Railway (positive train control);
- Surveying;
- Aviation (en-route navigation and non-precision approach landings).

In addition to these specific GPS/UWB operational scenarios, NTIA proposed a general operational scenario for GPS receivers used for terrestrial applications that considered multiple UWB device interactions.

As a result of the three public meetings, five categories of GPS applications are considered in the development of the GPS/UWB operational scenarios: terrestrial, maritime, railway, surveying, and aviation. The operational scenario proposals also considered several UWB device applications. The UWB device applications include: embedded functions in a mobile phone, wireless local area networks, and short-range communication systems.

---

<sup>53</sup> NTIA Notice at 1.

<sup>54</sup> All of the documents from the public meetings are available upon request from the NTIA Office of Spectrum Management or from the NTIA website.

### 3.2.1 Terrestrial Applications

The specific operational scenario proposals for the terrestrial use of GPS receivers include: public safety, geographic information systems, and precision machine control.<sup>55</sup> The operational scenario proposals for terrestrial GPS receivers are all based on a minimum distance separation between the GPS receiver and UWB device of 2 meters. Although this minimum distance separation may in some cases be applicable for assessing interference from a single UWB device, it is not used when assessing interference to GPS receivers from multiple UWB devices (10 meter minimum distance separation). The single UWB device and multiple UWB device operational scenarios for terrestrial applications are considered in this analysis.

#### 3.2.1.1 Single UWB Device

In the terrestrial operational scenario where a single UWB device interaction is considered, a minimum distance separation between the GPS receiver and the UWB device of 2 meters is used. At a minimum distance separation of 2 meters, it is appropriate to only consider the outdoor operation of UWB devices.

In the single UWB device terrestrial operational scenario, an antenna height of 3 meters is used for the GPS receiver and the UWB device. Based on the antenna model provided in Table 3-1, the antenna gain for the GPS receiver used in this operational scenario is 0 dBi.

For the GPS receiver and UWB device antenna heights of 3 meters, the expected propagation loss breakpoint radius is 568 meters. Since the minimum distance separation is much less than the expected propagation loss breakpoint radius, the free-space propagation model is applicable.

A summary of the technical factors associated with the single UWB device terrestrial operational scenario is provided in Table 3-2.

#### 3.2.1.2 Multiple UWB Devices

After reviewing the operational scenario proposals it is clear that the use of GPS for terrestrial applications is extremely diverse. This makes it difficult to identify a single representative operational scenario to be used in assessing the potential interference to terrestrial GPS receivers from multiple UWB devices. At the December 7, 2000 GPS/UWB operational scenario meeting NTIA presented an operational scenario proposal that considered interference to a terrestrial GPS receiver from multiple UWB devices.<sup>56</sup> In the analysis of multiple UWB devices both indoor and outdoor operation of UWB devices is considered.

---

<sup>55</sup> U.S. GPS Industry Council Submission to NTIA GPS/UWB Operational Scenario Meeting (Sept. 7, 2000).

<sup>56</sup> National Telecommunications and Information Administration, *Proposal for a General Operational Scenario for Assessing Potential Interference to Terrestrial Global Positioning System Receivers from Ultrawideband Transmission Systems* (Dec. 7, 2000).

**TABLE 3-2. Technical Factors for the Single UWB Device Terrestrial Operational Scenario**

Technical Factors	Value
GPS Receiver Antenna Gain	0 dBi
GPS Antenna Height	3 meters
UWB Device Antenna Height	3 meters
Minimum Distance Separation	2 meters
Propagation Model	Free-space
Interference Allotment to UWB Devices	0 dB (100%)
Variations in GPS Receivers	3 dB
Multiple UWB Devices	1 UWB device
Activity Factor for Each UWB Device	0 dB (100%)
Building Attenuation	0 dB
GPS Receiver Architecture	C/A-code

In the multiple UWB device terrestrial operational scenario, a minimum distance separation of 10 meters was established between the GPS receiver and a UWB device that is used outdoors. This was the distance separation that was presented at the GPS/UWB operational scenario meeting and is a reasonable to use when multiple UWB devices are being considered. For indoor operation, the UWB device is positioned above the GPS receiver (e.g., second floor of a building). The minimum distance separation is computed from the slant range with the GPS receiver located 5 meters from the building and the UWB device 10 meters above the GPS receiver. The following equation is used to compute the minimum distance separation:

$$D_{\min} = ((h_{\text{GPS}} - h_{\text{UWB}})^2 + D^2)^{0.5} \quad (5)$$

where:

$h_{\text{GPS}}$  is the height of the GPS receiver antenna (m);

$h_{\text{UWB}}$  is the height of the UWB device antenna (m);

D is the horizontal separation between the GPS receiver and UWB device antennas (m).

Based on the model given in Table 3-1 the antenna gain for the GPS receiver is 0 dBi and 3 dBi for outdoor and indoor operation of UWB devices respectively.



For a distance separation of 10 meters it is reasonable to consider multiple UWB devices. Four UWB devices each located 10 meters from the GPS receiver are considered in the multiple UWB terrestrial operational scenario.

Based on the established operational scenario an antenna height of 3 meters for the GPS receiver is used. An antenna height of 3 meters (outdoor operation) and 10 meters (indoor operation) is used for the UWB devices. Using these antenna heights the expected propagation loss breakpoint radii are 568 meters for UWB devices with a 3 meter antenna height and 1.9 kilometers for UWB devices with a 10 meter antenna height. Since the distance separation used in the multiple UWB general terrestrial operational scenario is less than the expected propagation loss breakpoint radii, the free-space propagation model is applicable.

A summary of the technical factors associated with the multiple UWB device terrestrial operational scenario is provided in Table 3-3.

**TABLE 3-3. Technical Factors for the Multiple UWB Device Terrestrial Operational Scenario**

<b>Technical Factors</b>	<b>Value (Outdoor Operation)</b>	<b>Value (Indoor Operation)</b>
GPS Receiver Antenna Gain	0 dBi	3 dBi
GPS Antenna Height	3 meters	3 meters
UWB Device Antenna Height	3 meters	10 meters
Minimum Distance Separation	10 meters	8.6 meters
Propagation Model	Free-space	Free-space
Interference Allotment to UWB Devices	(3 dB) 50%	3 (dB) 50%
Variations in GPS Receivers	3 dB	3 dB
Multiple UWB Devices	4 UWB devices	4 UWB devices
Activity Factor for Each UWB Device	0 dB (100%)	0 dB (100%)
Building Attenuation	0 dB	9 dB
GPS Receiver Architecture	C/A-code	

### 3.2.2 Maritime Applications

The operational scenario proposals for the maritime use of GPS receivers include: navigation in constricted waterways, harbor navigation, docking operations, navigation around bridges, and lock

operations.<sup>57</sup> The USCG has indicated that the limiting operational scenario for maritime applications is when the GPS receiver is used for navigation in constricted waterways. In this analysis, indoor and outdoor UWB device operation is considered.

In the two operational scenario proposals for navigation in constricted waterways, the GPS receiver antenna is assumed to be mounted on the mast of the vessel. Therefore, the minimum distance separation has both a horizontal and vertical component. The minimum distance separation between the GPS receiver and the UWB device is computed from the slant range using Equation 5.

The first restricted waterway operational scenario implementation uses an antenna height of 45 feet (13.5 meters) and a horizontal separation from the UWB devices of 125 feet (37.5 meters). The second implementation uses an antenna height of 25 feet (7.5 meters) and a horizontal separation from the UWB devices of 170 feet (51 meters). An antenna height of 3 meters (outdoor operation) and 10 meters (indoor operation) is used for the UWB devices. The computed minimum distance separations for the two implementations in the maritime navigation, constricted waterways operational scenario is given in Table 3-4.

**TABLE 3-4. Minimum Distance Separations for the Maritime Navigation in Constricted Waterways Operational Scenario**

<b>GPS Receiver Antenna Height (Meters)</b>	<b>UWB Device Antenna Height (Meters)</b>	<b>Minimum Distance Separation (Meters)</b>
13.5	3	38.9
7.5	3	51.2
13.5	10	37.7
7.5	10	51.1

For these minimum distance separations it is reasonable to consider multiple UWB devices. Four UWB devices each located at the minimum distance separations are considered in the maritime navigation in constricted waterways operational scenario.

Based on the model given in Table 3-1, when the off-axis angle is greater than -10 degrees the GPS antenna gain in the direction of the UWB device is 0 dBi. When the off-axis angle is less than -10 degrees the USCG has specified that the GPS antenna gain in the direction of the UWB device is -3 dBi.

---

<sup>57</sup> United States Coast Guard Navigation Center Submission to NTIA GPS/UWB Operational Scenario Meeting (Sept. 27, 2000).

Based on the GPS receiver antenna heights and the UWB device antenna heights the expected propagation loss breakpoint radii are computed and given in Table 3-5. Since the computed minimum distance separations are much less than the expected propagation loss breakpoint radii the free-space propagation model is applicable.

**TABLE 3-5. Expected Propagation Loss Breakpoint Radii for the Maritime Navigation in Constricted Waterways Operational Scenario**

<b>GPS Receiver Antenna Height (Meters)</b>	<b>UWB Device Antenna Height (Meters)</b>	<b>Propagation Loss Breakpoint Radii (Kilometers)</b>
13.5	3	2.5
7.5	3	1.4
13.5	10	8.5
7.5	10	4.7

A summary of the technical factors associated with the maritime navigation in constricted waterways operational scenario is provided in Table 3-6.

### 3.2.3 Railway Applications

The operational scenario proposal for the railway use of GPS receivers is for positive train control (PTC).<sup>58</sup> The specifics of this operational scenario proposal were provided by the NTIA.<sup>59</sup> In this analysis, indoor and outdoor operation of UWB devices is considered.

In the operational scenario proposal for PTC the GPS receiver antenna is mounted on top of the train. Therefore, the minimum distance separation has both a horizontal and vertical component. The minimum distance separation between the GPS receiver and the UWB device is computed from the slant range using Equation 5.

The GPS receiver antenna in the railway PTC operational scenario has an antenna height of 10 meters and a horizontal separation from the UWB devices of 7 meters. An antenna height of 3 meters (outdoor operation) and 10 meters (indoor operation) is used for the UWB devices. The computed minimum distance separations are 9.8 meters for outdoor UWB device operation and 7 meters for indoor UWB device operation.

---

<sup>58</sup> 1999 FRP at 2-25.

<sup>59</sup> *Summary of GPS/UWB Operational Scenarios* Prepared by the NTIA (Nov. 20, 2000) (hereinafter “NTIA Summary”).

**TABLE 3-6. Technical Factors for the Navigation in  
Constricted Waterways Operational Scenario**

<b>Technical Factors</b>	<b>Value (Outdoor Operation)</b>	<b>Value (Indoor Operation)</b>
GPS Receiver Antenna Gain	-3 and 0 dBi	0 dBi
GPS Antenna Height	13.5 and 7.5 meters	13.5 and 7.5 meters
UWB Device Antenna Height	3 meters	10 meters
Minimum Distance Separation	38.9 and 51.2 meters	37.7 and 51.1 meters
Propagation Model	Free-space	Free-space
Interference Allotment to UWB Devices	3 dB (50%)	3 dB (50%)
Variations in GPS Receivers	3 dB	3 dB
Multiple UWB Devices	4 UWB devices	4 UWB devices
Activity Factor for Each UWB Device	0 dB (100%)	0 dB (100%)
Building Attenuation	0 dB	9 dB
GPS Receiver Architecture	C/A-code	

Using the model given in Table 3-1, the antenna gain for the GPS receiver antenna is 0 dBi for indoor UWB device operation and -4.5 dBi for outdoor UWB device operation.

For these minimum distance separations, it is reasonable to consider multiple UWB devices. Three UWB devices each located at the minimum distance separation will be considered in the railway PTC operational scenario.

Based on the GPS receiver antenna heights and the UWB device antenna heights the expected propagation loss breakpoint radii are 1.9 kilometers for outdoor UWB device operation and 6.3 kilometers for indoor UWB device operation. Since the computed minimum distance separations are much less than the expected propagation loss breakpoint radii the free-space propagation model is applicable.

A summary of the technical factors associated with the railway PTC operational scenario is provided in Table 3-7.

**TABLE 3-7. Technical Factors for the Railway PTC Operational Scenario**

<b>Technical Factors</b>	<b>Value (Outdoor Operation)</b>	<b>Value (Indoor Operation)</b>
GPS Receiver Antenna Gain	-4.5 dBi	0 dBi
GPS Antenna Height	10 meters	10 meters
UWB Device Antenna Height	3 meters	10 meters
Minimum Distance Separation	9.8 meters	7 meters
Propagation Model	Free-space	Free-space
Interference Allotment to UWB Devices	3 dB (50%)	3 dB (50%)
Variations in GPS Receivers	3 dB	3 dB
Multiple UWB Devices	3 UWB devices	3 UWB devices
Activity Factor for Each UWB Device	0 dB (100%)	0 dB (100%)
Building Attenuation	0 dB	9 dB
GPS Receiver Architecture	C/A-code	

### 3.2.4 Surveying Applications

Two operational scenario proposals were provided for the surveying use of GPS receivers.<sup>60</sup> The surveying operational scenarios considered interference from both single and multiple UWB device interactions.

In the surveying operational scenarios the GPS receiver is located below the antenna of the UWB device. When a single UWB device is considered a minimum distance separation of 30 meters was proposed. For multiple UWB devices it was proposed that the first UWB device be located 30 meters from the GPS receiver. Two additional UWB devices are located at distances between 300 to 750 meters from the GPS receiver.

If an antenna height of 3 meters is used for the GPS receiver and 10 meters is used for the UWB device, the expected pathloss breakpoint radius is 1.2 kilometers. For the surveying operational scenarios the minimum distance separation is less than the expected pathloss breakpoint radius, therefore the free-space propagation model is applicable.

A summary of the technical factors associated with the surveying operational scenarios is provided in Table 3-8.

---

<sup>60</sup> National Oceanic and Atmospheric Administration/National Ocean Service/National Geodetic Survey Submission to NTIA GPS/UWB Operational Scenario Meeting (Sept. 27, 2000).

**TABLE 3-8. Technical Factors for the Surveying Operational Scenarios**

Technical Factors	Value (Single UWB Device)	Value (Multiple UWB Devices)
GPS Receiver Antenna Gain	3 dBi	3 dBi, 0 dBi
GPS Antenna Height	3 meters	3 meters
UWB Device Antenna Height	10 meters	10 meters
Minimum Distance Separation	30 meters	30, 300, 750 meters
Propagation Model	Free-space	Free-space
Interference Allotment to UWB Devices	3 dB (50%)	3 dB (50%)
Variations in GPS Receivers	3 dB	3 dB
Multiple UWB Devices	1 UWB device	3 UWB devices
Activity Factor for Each UWB Device	0 dB (100%)	0 dB (100%)
Building Attenuation	0 dB	0 dB
GPS Receiver Architecture	Semi-Codeless	

### 3.2.5 Aviation Applications <sup>61</sup>

The operational scenario proposals for the aviation use of GPS receivers include: en-route navigation and non-precision approach landings.<sup>62</sup> En-route navigation is a phase of navigation covering operations between a point of departure and termination of the flight. Non-precision approach landing is a standard instrument approach procedure using a ground-based system in which no electronic glide slope is provided.<sup>63</sup>

---

<sup>61</sup> Another aviation application that was discussed at the NTIA operational scenario meetings, was the use of GPS receivers in airport surface movement operations. Sufficient information is not available at this time to include an assessment of this operational scenario in this report. This operational scenario is being actively addressed within RTCA and the results will be made available when the study is complete.

<sup>62</sup> NTIA Summary at 10.

<sup>63</sup> Glide slope is a descent profile determined for vertical guidance during a final approach.

### 3.2.5.1 En-Route Navigation

For the en-route navigation operational scenario, the aircraft with the GPS receiver is at an altitude of 1,000 feet.<sup>64</sup> The maximum LOS distance ( $d_{\text{LOS}}$ ) for an aircraft at an altitude of 303 meters (1,000 feet) is given by:

$$d_{\text{LOS}} = 3.57 (k)^{0.5} ((h_{\text{UWB}})^{0.5} + (h_{\text{GPS}})^{0.5}) \quad (6)$$

where:

$k$  is the effective Earth radius factor;

$h_{\text{UWB}}$  is the antenna height of the UWB device (m);

$h_{\text{GPS}}$  is the height of the GPS receiver antenna located on the aircraft (m).

Using an antenna height of 3 meters for the UWB device and a typical value of  $k$  in a temperate climate of 1.33, the computed LOS distance for the aircraft is 78.5 kilometers. Since such a large geographic area is visible to an aircraft at this altitude, the impact of multiple UWB devices is considered for the aviation en-route navigation operational scenario.

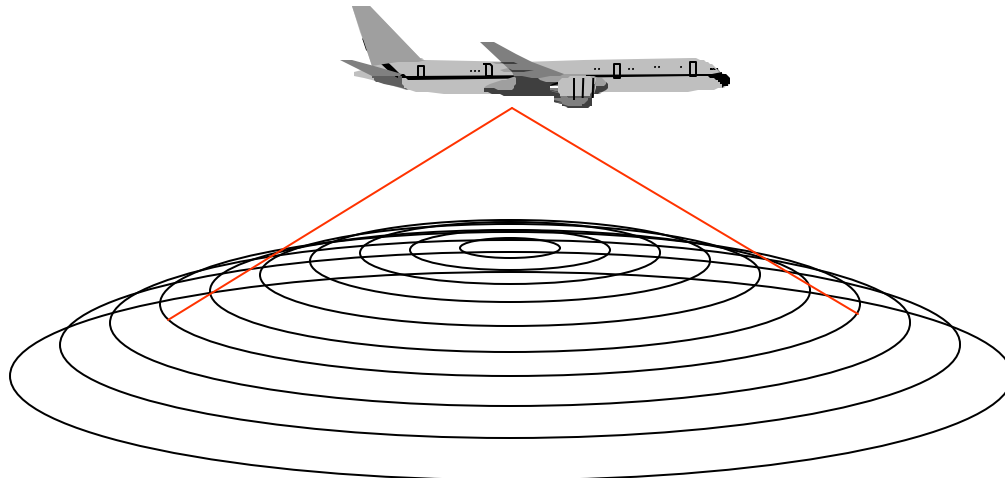
To compute the aggregate emission level into the GPS receiver from multiple UWB devices a computer model developed by NTIA is used. This computer model computes the power-sum aggregate emission level from a surface density of UWB devices with the same emission frequency and emission level. The computer model assumes that all of the UWB devices are radiating in the direction of the airborne GPS receiver. The UWB devices are distributed uniformly in concentric rings on a spherical dome of the Earth's surface as shown in Figure 3-1 such that the distance from any UWB device to its closest neighbor remains approximately constant throughout the distribution. A 4/3 Earth-radius model is assumed for ray bending effects, and the free-space propagation model is employed for propagation loss computations. A detailed description of the computer model is provided in a separate NTIA report.<sup>65</sup>

Determining the density of a large number of UWB devices is a key factor affecting the aggregate interference to a GPS receiver used for en-route navigation. Factors that should be considered when estimating the density of a large number of UWB devices include: population; assumed rate for technology penetration; and activity factor. In the absence of such information, this analysis computes the maximum allowable EIRP as a function of active UWB device density.

---

<sup>64</sup> Document No. RTCA/DO-235, *Assessment of Radio Frequency Interference Relevant to the GNSS* (Jan. 27, 1997) at A-2 (hereinafter "DO-235").

<sup>65</sup> National Telecommunications and Information Administration, U.S. Department of Commerce, NTIA Special Publication 01-43, *Assessment of Compatibility Between Ultra-Wideband Devices and Selected Federal Systems* (Jan. 2001) at 5-5.



**Figure 3-1. Airborne Geometry for the NTIA Aggregate Emitter Model**

Indoor and outdoor operation of UWB devices is considered in the aviation en-route navigation operational scenario. Since it is not possible to estimate what percentage of the UWB devices are operating indoor versus those operating outdoor, two cases are considered. In the first case all of the UWB devices are operating outdoors and in the second case all of the UWB devices are operating indoors.

In the en-route operational scenarios, the GPS receiver antenna is located on top of the aircraft. In a previous analysis of terrestrial interference to GPS receivers, an antenna gain below the aircraft of -10 dBi was used.<sup>66</sup> Since there are no specifications on antenna gain below the aircraft and sufficient installed antenna pattern data is lacking on civil aircraft the value of antenna gain of -10 dBi will be used in the aviation en-route navigation operational scenario.

Since en-route navigation is a safety-of-life function it is appropriate to include a 6 dB safety margin in this operational scenario.

A summary of the technical factors associated with the aviation en-route navigation operational scenario is provided in Table 3-9.

---

<sup>66</sup> DO-235 at F-13.



**TABLE 3-9. Technical Factors for the Aviation En-Route Navigation Operational Scenario**

<b>Technical Factors</b>	<b>Value (Outdoor Operation)</b>	<b>Value (Indoor Operation)</b>
GPS Receiver Antenna Gain	-10 dBi	-10 dBi
GPS Antenna Height	303 meters	303 meters
UWB Device Antenna Height	3 meters	3 meters
Minimum Distance Separation	303 meters	303 meters
Propagation Model	Free-space	Free-space
Interference Allotment to UWB Devices	10 dB (10%)	10 dB (10%)
Variations in GPS Receivers	3 dB	3 dB
Aviation Safety Margin	6 dB	6 dB
Multiple UWB Devices	Variable	Variable
Activity Factor for Each UWB Device	0 dB (100%)	0 dB (100%)
Building Attenuation	0 dB	9 dB
GPS Receiver Architecture	C/A-code	

### 3.2.5.2 Non-Precision Approach Landing

The FAA distinguishes a precision approach from a non-precision approach landing by requiring a precision approach to have a combined lateral and vertical (glide slope) guidance. The term non-precision approach refers to facilities without a glide slope. The FAA maintains the same level of flight safety for non-precision approaches as it does for precision approaches. They achieve this equity by requiring a much larger displacement area at the missed approach point and a higher minimum descent height (MDH) for the non-precision approach landings than they do for the precision approach landings. The MDH is the lowest altitude to which descent shall be authorized for procedures not using a glide slope (vertical guidance).

Associated with each non-precision approach landing segment there is a MDH. The MDH is computed by:

$$\text{MDH} = 250 \text{ feet} + (\text{Obstacle Height}) \tag{7}$$

If there are no obstructions, then the MDH is 250 feet. Assuming that a UWB device can be

located on top of an obstacle, or at ground level within an obstacle-free zone, and assuming that the GPS antenna is located 7 feet above the aircraft control point, the following equation is used to compute the minimum distance separation between the GPS receiver used for non-precision approach landings and a UWB device:

$$D_{\min} = 257 - \text{TSE} \quad (8)$$

where TSE is the Total System Error.

The TSE comprises both the aircraft and its navigation system tracking errors. It is the difference between true position and desired position. The TSE is computed from the root-sum-square of the Flight Technical Error (FTE) and the Navigation System Error (NSE):

$$\text{TSE} = ((\text{FTE})^2 + (\text{NSE})^2)^{0.5} \quad (9)$$

The FTE is the error contribution of the pilot using the presented information to control aircraft position. The NSE is the error attributable to the navigation system in use. It includes the navigation sensor error, receiver error, and path definition error.

The 95% probability (2 $\sigma$ ) value for the FTE is 100 feet.<sup>67</sup> The NSE for the vertical guidance for the 3 $\sigma$  value is 103 feet corresponding to the minimum accuracy requirements for vertical guidance equipment.<sup>68</sup> Based on the 3 $\sigma$  value, the 2 $\sigma$  value for NSE is then 68.6 feet. Using Equation 9 the TSE is then 121.2 feet. Using Equation 8, the minimum distance separation between the GPS receiver used for the non-precision approach landings and a UWB devices is 135.8 feet.

In the previous analyses that have been performed examining interference from terrestrial emitters to a GPS receiver used for precision approach landings it was assumed that a single emitter was below the aircraft and located at the Category I decision point. The effect of multiple interfering emitters was not considered in this analysis. A methodology was presented in RTCA Working Group 6 to address multiple interfering sources.<sup>69</sup> As an aircraft passes over the UWB devices, the antenna located on top of the aircraft projects a plane on the surface of the Earth as shown in Figure 3-2. As shown in Figure 3-2, point P represents the GPS receiver antenna. The surface E represents the plane containing the interfering sources. The parameter h is the minimum distance from point P to plane E. The parameter d is the distance from points on plane E whose propagation loss differs from the minimum loss at distance h by a fixed propagation loss ratio (LR). The parameter r is the radius of the plane (circle) containing the points of the fixed propagation loss ratio. The radius of this circle is given by:

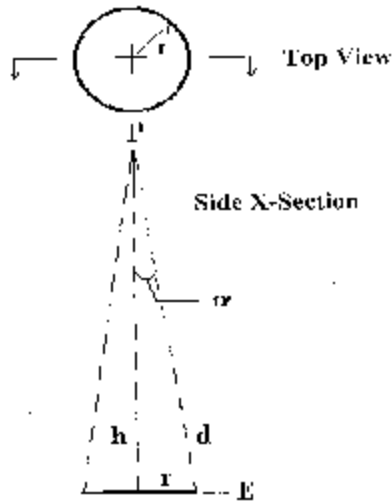
$$r = h (\text{LR}-1)^{0.5} \quad (10)$$

---

<sup>67</sup> Document No. RTCA/DO-208, *Minimum Operational Performance Standards for Airborne Supplemental Navigation Equipment Using GPS* (July 1991) at E-4.

<sup>68</sup> *Id.* at 34.

<sup>69</sup> R. J. Erlandson, Rockwell Collins, *UWB Cumulative RFI Effects Aspects for Aviation Precision Approach Scenarios*, SC-159 WG 6 Presentation (Oct. 25, 2000).



**Figure 3-2. Airborne Antenna Projection Geometry**

A derivation of Equation 10 is provided in Appendix A. Another factor to be considered is the variation in antenna gain. This can be examined from the angle  $\acute{a}$  in Figure 3-2 using the following equation:

$$\acute{a} = \cos^{-1} (1/(LR)^{0.5}) \quad (11)$$

A derivation for Equation 11 is also provided in Appendix A.

In determining a representative value for LR, the variation in antenna gain should be taken into consideration. Although the antenna gain specified in Table 3-1 shows a constant antenna gain in the region of -90 to -10 degrees, the actual antenna pattern contains many peaks and nulls (maximum and minimum values of antenna gain).<sup>70</sup> Therefore, the value of LR should be selected to minimize the variation in antenna gain, thereby permitting the use of a single representative antenna gain in the analysis. Using Equation 10 with the minimum distance separation of 136 feet and a propagation loss ratio of 0.1 dB, a circle with a radius of 20.7 feet (41.4 feet in diameter) is computed. For the fixed propagation loss ratio of 0.1 dB, the computed antenna cone angle ( $\acute{a}$ ) is 8.68 degrees. This angle is assumed to be small enough to neglect antenna gain variations and will permit the use of a single value of antenna gain in the analysis.

A circle with a diameter of 41.4 feet is large enough to contain several UWB devices. In the aviation non-precision approach landing operational scenario four UWB devices are considered.

---

<sup>70</sup> DO-235 at Appendix E Annex 2.

In the non-precision approach landing operational scenario, the GPS receiver antenna is located on top of the aircraft. As discussed in the en-route navigation operational scenario, a previous analysis of terrestrial interference to GPS receivers used an antenna gain below the aircraft of -10 dBi. Since there are no specifications on antenna gain below the aircraft and sufficient installed antenna pattern data is lacking on civil aircraft an antenna gain of -10 dBi will be used in this operational scenario.

In this operational scenario, the minimum distance separation between the GPS receiver and the UWB devices is 136 feet. Typically, when the aircraft is at this altitude there are no buildings or structures that are located along the area approaching the runway. Therefore, this analysis only considers UWB devices that are operating outdoors.

Since non-precision approach landings are considered a safety-of-life function it is appropriate to include a 6 dB safety margin in this operational scenario.

A summary of the technical factors associated with the aviation non-precision approach landing operational scenario is provided in Table 3-10.

**TABLE 3-10. Technical Factors for the Aviation Non-Precision Approach Landing Operational Scenario**

<b>Technical Factors</b>	<b>Value</b>
GPS Receiver Antenna Gain	-10 dBi
GPS Antenna Height	41.4 meters
UWB Device Antenna Height	3 meters
Minimum Distance Separation	41.4 meters
Propagation Model	Free-space
Interference Allotment to UWB Devices	10 dB (10%)
Variations in GPS Receivers	3 dB
Aviation Safety Margin	6 dB
Multiple UWB Devices	4 UWB devices
Activity Factor for Each UWB Device	0 dB (100%)
Building Attenuation	0 dB
GPS Receiver Architecture	C/A-code

### 3.3 ANALYSIS RESULTS

The results of the analysis are presented in this section. Prior to using the measured interference susceptibility levels ( $I_{\text{meas}}$ ) in the analysis, adjustments must be made based on the signal structure of the interfering signal to compute the UWB interference threshold ( $I_T$ ).

For signals that have been characterized as causing CW-like interference, the value of  $I_T$  used in the analysis is based on the power in a single spectral line. As such, the computed values of maximum allowable EIRP represents the power in a single CW-line, independent of the modulation employed.

For interfering signals that have been characterized as causing pulse-like interference, the value of  $I_{\text{meas}}$  used to compute  $I_T$ , was the average measured value. In those cases where neither a break-lock (BL) or reacquisition (RQT) threshold could be measured, this was referred to as Did Not Break Lock (DNBL). The value of  $I_{\text{meas}}$  used in the analysis was the maximum available UWB power. It should be noted that the maximum available UWB power was limited by the peak power of the UWB generator. In the case of UWB signals employing 20% gating, where neither a BL or RQT condition was obtained, the maximum available UWB power was reduced by a factor of  $10 \log$  (gating percentage) to obtain an average value for  $I_T$ . This can result in an incongruous situation, where the computed value of maximum allowable EIRP is lower for the gated UWB signal versus the non-gated signal.

The GPS receivers considered in the analysis employ one of two receiver architectures: C/A-code and semi-codeless. A GPS receiver that employs C/A-code architecture processes the transmitted C/A-code signal, which has a null-to-null bandwidth of 2.046 MHz. A GPS receiver that employs the semi-codeless architecture, processes the transmitted P-code signals at the L1 and L2 frequencies to provide a measure of ionospheric delay. This permits a correction to pseudorange for ionospheric effects. The P-code signal has a null-to-null bandwidth of 20.46 MHz. Since the signals processed by the two GPS receiver architectures have different spectral characteristics, adjustments must be made to the values of  $I_{\text{meas}}$  before they can be used in the analysis.

The C/A signal has an approximate  $\text{sinc}^2$  power spectral envelope with a null-to-null bandwidth of 2.046 MHz. GPS employs a family of short pseudo-random codes known as Gold codes to generate the different pseudo-random sequences of the C/A-code signal. Due to the short period (1 ms) length Gold code there are distinct spectral lines spaced 1 kHz apart. The spectral lines deviate from the  $\text{sinc}^2$  envelope enough to create dominant spectral lines that are more vulnerable to CW interference. In the measurements when a UWB signal structure contains spectral lines, one of the lines is placed close (nominally 500 Hz) to a dominant GPS spectral line. As discussed in Section 2.2, when a UWB signal structure contains spectral lines an adjustment is made to the measured interference susceptibility level to determine the power in the spectral line prior to using this level in the analysis. An adjustment is made to the measured interference susceptibility levels when gating is employed. When the UWB signal appears noise-like an adjustment must also be made to the measured interference susceptibility level to correct for the difference in the measurement bandwidth (20 MHz) and the bandwidth used in the analysis (1 MHz). Section 2.2.2.1 provides a more detailed discussion of the adjustments made to

the measured susceptibility levels based on the UWB signal structure. Table 3-11 provides the equations as a function of the interfering signal structure that are necessary to compute the UWB interference thresholds used in the analysis for GPS receivers employing the C/A-code architecture.

The P-code signals at the L1 and L2 frequencies have a chipping rate of 10.23 Mchips/sec and a code repetition rate of 1 week. The P-code signals have a  $\text{sinc}^2$  power spectral envelope with a null-to-null bandwidth of 20.46 MHz. Unlike the C/A-code, the P-code signal has essentially no spectral lines. As a result of the correlation process all of the UWB signals will appear to be pulse-like or noise-like at the output of the correlator. Table 3-12 provides the equations as a function of the interfering signal structure that are necessary to compute the UWB interference threshold used in the analysis for GPS receivers employing the semi-codeless architecture.

**TABLE 3-11. Equations Used to Compute the Single-Entry UWB Interference Threshold for C/A-code GPS Receiver Architecture**

Interfering Signal Structure	UWB Interference Threshold Equation
Broadband Noise	$I_T = I_{meas} \text{ (dBm/20MHz)} - 30 \text{ (dBW/dBm)} - 10 \text{ Log (20 MHz/1 MHz)}$
PRF: 100 kHz Modulation: None Gating: 100%	$I_T = I_{meas} \text{ (dBm/20MHz)} - 30 \text{ (dBW/dBm)} - 10 \text{ Log (20 MHz/1 MHz)}$
PRF: 1, 5, and 20 MHz Modulation: None Gating: 100%	$I_T = I_{meas} \text{ (dBm/20MHz)} - 30 \text{ (dBW/dBm)} - 10 \text{ Log (# of lines in a 20 MHz bandwidth)}$ 1 line (20 MHz), 5 lines (5 MHz), and 21 lines (1 MHz)
PRF: 100 kHz and 1MHz Modulation: None Gating: 20%	$I_T = I_{meas} \text{ (dBm/20MHz)} - 30 \text{ (dBW/dBm)} - 10 \text{ Log (20 MHz/1 MHz)} + 10 \text{ Log (Gating \%)}$
PRF: 5 and 20 MHz Modulation: None Gating: 20%	$I_T = I_{meas} \text{ (dBm/20MHz)} - 30 \text{ (dBW/dBm)} - 10 \text{ Log (# of lines in a 20 MHz bandwidth)} + 10 \text{ Log (Gating \%)} - 7 \text{ dB}^1$ 1 line (20 MHz) and 5 lines (5 MHz)
PRF: 100 kHz, 1, 5, and 20 MHz Modulation: 2% Rel. and 50% Abs. Dithering Gating: 100%	$I_T = I_{meas} \text{ (dBm/20MHz)} - 30 \text{ (dBW/dBm)} - 10 \text{ Log (20 MHz/1 MHz)}$
PRF: 100 kHz, 1, 5, and 20 MHz Modulation: 2% Rel. and 50% Abs. Dithering Gating: 20%	$I_T = I_{meas} \text{ (dBm/20MHz)} - 30 \text{ (dBW/dBm)} - 10 \text{ Log (20 MHz/1 MHz)} + 10 \text{ Log (Gating \%)}$
PRF: 100 kHz and 1MHz Modulation: OOK Gating: 100%	$I_T = I_{meas} \text{ (dBm/20MHz)} - 30 \text{ (dBW/dBm)} - 10 \text{ Log (20 MHz/1 MHz)}$
PRF: 5 and 20 MHz Modulation: OOK Gating: 100%	$I_T = I_{meas} \text{ (dBm/20MHz)} - 3\text{dB}^2 - 30 \text{ (dBW/dBm)} - 10 \text{ Log (# of lines in a 20 MHz bandwidth)}$ 1 line (20 MHz) and 5 lines (5 MHz)
PRF: 100 kHz and 1MHz Modulation: OOK Gating: 20%	$I_T = I_{meas} \text{ (dBm/20MHz)} - 30 \text{ (dBW/dBm)} - 10 \text{ Log (20 MHz/1 MHz)} + 10 \text{ Log (Gating \%)}$
PRF: 5 and 20 MHz Modulation: OOK Gating: 20%	$I_T = I_{meas} \text{ (dBm/20MHz)} - 3\text{dB}^2 - 30 \text{ (dBW/dBm)} - 10 \text{ Log (# of lines in a 20 MHz bandwidth)} + 10 \text{ Log (Gating \%)} - 7\text{dB}^1$ 1 line (20 MHz) and 5 lines (5 MHz)
<p>Notes:</p> <ol style="list-style-type: none"> <li>1. Adjustment to compute the power in a single spectral line that is spread in frequency by the gating period resulting in a sinc<sup>2</sup> shape around each line.</li> <li>2. Adjustment for the division of power between discrete spectral lines and continuous spectrum for OOK modulated UWB signal.</li> </ol>	

**TABLE 3-12. Equations Used to Compute the Single-Entry UWB Interference Threshold for Semi-Codeless GPS Receiver Architectures**

Interfering Signal Structure	UWB Interference Threshold Equation
Broadband Noise	$I_T = I_{meas} \text{ (dBm/20MHz)} - 30 \text{ (dBW/dBm)} - 10 \text{ Log (20 MHz/1 MHz)}$
PRF: 100 kHz, 1, 5, and 20 MHz Modulation: None Gating: 100%	$I_T = I_{meas} \text{ (dBm/20MHz)} - 30 \text{ (dBW/dBm)} - 10 \text{ Log (20 MHz/1 MHz)}$
PRF: 100 kHz, 1, 5 and 20 MHz Modulation: None Gating: 20%	$I_T = I_{meas} \text{ (dBm/20MHz)} - 30 \text{ (dBW/dBm)} - 10 \text{ Log (20 MHz/1 MHz)} + 10 \text{ Log (Gating \%)}$
PRF: 100 kHz, 1, 5, and 20 MHz Modulation: 2% Rel. and 50% Abs. Dithering Gating: 100%	$I_T = I_{meas} \text{ (dBm/20MHz)} - 30 \text{ (dBW/dBm)} - 10 \text{ Log (20 MHz/1 MHz)}$
PRF: 100 kHz, 1, 5, and 20 MHz Modulation: 2% Rel. and 50% Abs. Dithering Gating: 20%	$I_T = I_{meas} \text{ (dBm/20MHz)} - 30 \text{ (dBW/dBm)} - 10 \text{ Log (20 MHz/1 MHz)} + 10 \text{ Log (Gating \%)}$
PRF: 100 kHz, 1, 5 , and 20 MHz Modulation: OOK Gating: 100%	$I_T = I_{meas} \text{ (dBm/20MHz)} - 30 \text{ (dBW/dBm)} - 10 \text{ Log (20 MHz/1 MHz)}$
PRF: 100 kHz, 1, 5, and 20 MHz Modulation: OOK Gating: 20%	$I_T = I_{meas} \text{ (dBm/20MHz)} - 30 \text{ (dBW/dBm)} - 10 \text{ Log (20 MHz/1 MHz)} + 10 \text{ Log (Gating \%)}$

Tables 3-13 and 3-14 provide the UWB interference thresholds for each of the GPS receiver architectures measured. The single-entry UWB interference threshold and the GPS receiver criteria used to determine the levels are shown for the different interfering signal structures considered in this analysis.



**TABLE 3-13. Single-Entry UWB Interference Thresholds for C/A-code Receiver Architectures**

<b>Interfering Signal Structure</b>	<b>UWB Interference Threshold</b>	<b>GPS Receiver Criteria</b>
Broadband Noise	-134.5 dBW/MHz	Reacquisition
0.1 MHz PRF, No Mod, 100% Gate	-112.6 dBW/MHz	Break-Lock
0.1 MHz PRF, No Mod, 20% Gate	-106.5 dBW/MHz <sup>a</sup>	Did Not Break-Lock At Maximum Available UWB Power
0.1 MHz PRF, OOK, 100% Gate	-102.6 dBW/MHz <sup>a</sup>	Did Not Break-Lock At Maximum Available UWB Power
0.1 MHz PRF, OOK, 20% Gate	-109.4 dBW/MHz <sup>a</sup>	Did Not Break-Lock At Maximum Available UWB Power
0.1 MHz PRF, 50% abs, 100% Gate	-100 dBW/MHz <sup>a</sup>	Did Not Break-Lock At Maximum Available UWB Power
0.1 MHz PRF, 50% abs, 20% Gate	-107 dBW/MHz <sup>a</sup>	Did Not Break-Lock At Maximum Available UWB Power
0.1 MHz PRF, 2% rel, 100% Gate	-100 dBW/MHz <sup>a</sup>	Did Not Break-Lock At Maximum Available UWB Power
0.1 MHz PRF, 2% rel, 20% Gate	-107 dBW/MHz <sup>a</sup>	Did Not Break-Lock At Maximum Available UWB Power
1 MHz PRF, No Mod, 100% Gate	-143.7 dBW	Break-Lock
1 MHz PRF, No Mod, 20% Gate	-97.6 dBW/MHz <sup>a</sup>	Did Not Break-Lock At Maximum Available UWB Power
1 MHz PRF, OOK, 100% Gate	-121.2 dBW/MHz	Break-Lock
1 MHz PRF, OOK, 20% Gate	-101.1 dBW/MHz <sup>a</sup>	Did Not Break-Lock At Maximum Available UWB Power
1 MHz PRF, 50% abs, 100% Gate	-113 dBW/MHz	Reacquisition
1 MHz PRF, 50% abs, 20% Gate	-97.5 dBW/MHz <sup>a</sup>	Did Not Break-Lock At Maximum Available UWB Power
1 MHz PRF, 2% rel, 100% Gate	-131 dBW/MHz	Reacquisition
1 MHz PRF, 2% rel, 20% Gate	-97 dBW/MHz	Reacquisition
5 MHz PRF, No Mod, 100% Gate	-145.5 dBW	Break-Lock
5 MHz PRF, No Mod, 20% Gate	-145.2 dBW	Break-Lock
5 MHz PRF, OOK, 100% Gate	-144.5 dBW	Break-Lock
5 MHz PRF, OOK, 20% Gate	-144.2 dBW	Break-Lock
5 MHz PRF, 50% abs, 100% Gate	-137 dBW/MHz	Reacquisition
5 MHz PRF, 50% abs, 20% Gate	-105 dBW/MHz	Reacquisition
5 MHz PRF, 2% rel, 100% Gate	-136.5 dBW/MHz	Reacquisition
5 MHz PRF, 2% rel, 20% Gate	-89 dBW/MHz <sup>a</sup>	Did Not Break-Lock At Maximum Available UWB Power
20 MHz PRF, No Mod, 100% Gate	-145 dBW	Break-Lock
20 MHz PRF, No Mod, 20% Gate	-145.8 dBW	Break-Lock
20 MHz PRF, OOK, 100% Gate	-144.5 dBW	Break-Lock
20 MHz PRF, OOK, 20% Gate	-146.3 dBW	Break-Lock
20 MHz PRF, 50% abs, 100% Gate	-138 dBW/MHz	Reacquisition
20 MHz PRF, 50% abs, 20% Gate	-135 dBW/MHz	Reacquisition
20 MHz PRF, 2% rel, 100% Gate	-136 dBW/MHz	Reacquisition
20 MHz PRF, 2% rel, 20% Gate	-133 dBW/MHz	Reacquisition

Note: a. Interference threshold not reached at maximum available UWB generator power.

**TABLE 3-14. Single-Entry UWB Interference Thresholds for Semi-Codeless Receiver Architectures**

Interfering Signal Structure	UWB Interference Threshold	GPS Receiver Criteria
Broadband Noise	-150 dBW/MHz	Reacquisition
0.1 MHz PRF, No Mod, 100% Gate	-118 dBW/MHz	Reacquisition
0.1 MHz PRF, No Mod, 20% Gate	-116.5 dBW/MHz <sup>a</sup>	Did Not Break-Lock At Maximum Available UWB Power
0.1 MHz PRF, OOK, 100% Gate	-112 dBW/MHz <sup>a</sup>	Did Not Break-Lock At Maximum Available UWB Power
0.1 MHz PRF, OOK, 20% Gate	-118.5 dBW/MHz <sup>a</sup>	Did Not Break-Lock At Maximum Available UWB Power
0.1 MHz PRF, 50% abs, 100% Gate	-121 dBW/MHz	Reacquisition
0.1 MHz PRF, 50% abs, 20% Gate	-116 dBW/MHz <sup>a</sup>	Did Not Break-Lock At Maximum Available UWB Power
0.1 MHz PRF, 2% rel, 100% Gate	-119 dBW/MHz	Reacquisition
0.1 MHz PRF, 2% rel, 20% Gate	-138 dBW/MHz	Reacquisition
1 MHz PRF, 50% abs, 100% Gate	-151 dBW/MHz	Reacquisition
1 MHz PRF, 50% abs, 20% Gate	-132 dBW/MHz	Reacquisition
1 MHz PRF, 2% rel, 100% Gate	-149 dBW/MHz	Reacquisition
1 MHz PRF, 2% rel, 20% Gate	-134 dBW/MHz	Reacquisition
5 MHz PRF, 50% abs, 100% Gate	-151 dBW/MHz	Reacquisition
5 MHz PRF, 50% abs, 20% Gate	-151 dBW/MHz	Reacquisition
5 MHz PRF, 2% rel, 100% Gate	-149 dBW/MHz	Reacquisition
5 MHz PRF, 2% rel, 20% Gate	-142.5 dBW/MHz	Reacquisition
20 MHz PRF, No Mod, 100% Gate	-145 dBW/MHz	Break-Lock
20 MHz PRF, No Mod, 20% Gate	-148 dBW/MHz	Break-Lock
20 MHz PRF, OOK, 100% Gate	-137 dBW/MHz	Break-Lock
20 MHz PRF, OOK, 20% Gate	-146 dBW/MHz	Break-Lock
20 MHz PRF, 50% abs, 100% Gate	-149.5 dBW/MHz	Reacquisition
20 MHz PRF, 50% abs, 20% Gate	-148 dBW/MHz	Reacquisition
20 MHz PRF, 2% rel, 100% Gate	-149.5 dBW/MHz	Reacquisition
20 MHz PRF, 2% rel, 20% Gate	-143.5 dBW/MHz	Reacquisition

Note: a. Interference threshold not reached at maximum available UWB generator power.

Sections 3.3.1 through 3.3.5 present the results of the analysis. Each section gives the analysis results for one of the five categories of GPS receiver applications considered. For each GPS receiver application several operational scenarios were analyzed. The analysis results are presented in the form of graphs where the bar represents the value of maximum allowable EIRP (e.g., a longer bar represents a lower value of maximum allowable EIRP). Both single and multiple UWB device interactions were considered. In a multiple UWB device interaction, the maximum allowable EIRP level of a single UWB

device as shown on the graph was determined by partitioning the total interference allotment in accordance with the multiple (aggregate) UWB device factor as discussed in Section 3.1.4.

The maximum allowable EIRP (based on average power) of a single UWB device is displayed on the x-axis. The UWB signal permutations examined are displayed on the y-axis. Each UWB signal permutation is identified by three parameters: PRF, gating percentage, and modulation type. For example, a UWB signal employing a PRF of 1 MHz, 20% gating, and on-off keying modulation is identified as: 1MHz, 20%, OOK.

In addition to identifying the UWB signal parameters, each entry on the y-axis identifies the criteria used in the single-entry interference measurements, which were then used to compute the UWB interference thresholds. As discussed in Section 1.3.1, the two GPS receiver criteria used in this assessment are break-lock and reacquisition identified on the y-axis as BL and RQT respectively. UWB signal permutations for which neither a break-lock or reacquisition condition could be measured are identified on the y-axis as DNBL. For these signal permutations, the maximum available UWB signal power was used in the analysis. When multiple UWB devices were considered, resulting in noise-like interference, the UWB interference threshold was computed based on the broadband noise reacquisition threshold. This is identified as NRQT on the y-axis.

The results of the spreadsheet analysis program used to generate the graphs are provided in Appendix B.

There is a vertical dashed line shown on each graph that represents the current Part 15 level of -71.3 dBW/MHz. UWB signals that have been characterized as causing noise-like or pulse-like interference can be directly compared to the current Part 15 level. UWB signals that have been characterized as causing CW-like interference can be compared to the current level, if it is assumed that there is only a single spectral line in the measurement bandwidth. When the value of maximum allowable EIRP associated with a UWB signal permutation is located on the left side of the dashed line, additional attenuation below the current Part 15 level is not necessary in order to protect the GPS receiver architecture under consideration. When the value of maximum allowable EIRP associated with a UWB signal permutation is located on the right side of the dashed line, additional attenuation below the current Part 15 level is necessary to protect the GPS receiver architecture under consideration. For example, if the value of maximum allowable EIRP is -93 dBW/MHz, 21.7 dB of additional attenuation below the current Part 15 level is necessary to protect the GPS receiver architecture under consideration.

Three graphs are given for each of the operational scenarios that were analyzed. The first graph presents the analysis results for the UWB signal permutations that have been characterized as causing pulse-like interference. The second graph presents the analysis results for the UWB signal permutations that have been characterized as causing noise-like interference. The third graph presents the analysis results for the UWB signal permutations that have been characterized as causing CW-like interference.

### 3.3.1 Terrestrial Applications

In the operational scenarios for the terrestrial applications, the C/A-code receiver architecture is considered. The analysis results for the C/A-code receiver architecture are given in Figures 3-3 through 3-11. The operational scenarios considered both single and multiple UWB device interactions as well as indoor and outdoor UWB device operation. The values of maximum allowable EIRP shown in Figures 3-3 through 3-11 are for a single UWB device and are based on average power.

The values of maximum allowable EIRP that are required to protect the C/A-code receiver architecture considered in the terrestrial application operational scenarios will vary depending on the UWB signal parameters, single versus multiple UWB device interactions, and whether the UWB devices are used indoors or outdoors. The analysis results for the operational scenarios associated with terrestrial applications can be discussed in terms of the characterization of the UWB signal interference effects. As shown in Figure 3-3 the maximum allowable EIRP for the UWB signals that have been characterized as causing pulse-like interference range from -95.6 to -49.6 dBW/MHz for single UWB device interactions. Figures 3-6 and 3-9 show that for multiple UWB device interactions resulting in pulse-like interference, the values of maximum allowable EIRP range from -62.3 to -49.7 dBW/MHz for outdoor UWB device operation and -57.6 to -45 dBW/MHz for indoor UWB device operation. As shown in Figure 3-4 for UWB signals that have been characterized as causing noise-like interference, the values of maximum allowable EIRP range from -98.6 to -96.6 dBW/MHz for single UWB device interactions. As shown in Figures 3-7 and 3-10, for multiple UWB interactions resulting in noise-like interference, the values of maximum allowable EIRP range from -89 to -85.5 dBW/MHz for indoor UWB operation and -93.7 to -90.2 dBW/MHz for outdoor UWB device operation. Figures 3-5, 3-8, and 3-11 give the analysis results for the UWB signals that have been characterized as causing CW-like interference. As shown in Figure 3-5, the values of maximum allowable EIRP range from -106.9 to -104.3 dBW for single UWB device interactions. Figures 3-8 and 3-11 show that for multiple UWB device interactions, the values of maximum allowable EIRP range from -91.3 to -88.7 dBW for indoor UWB device operation and -96 to -93.4 dBW for outdoor UWB operation.

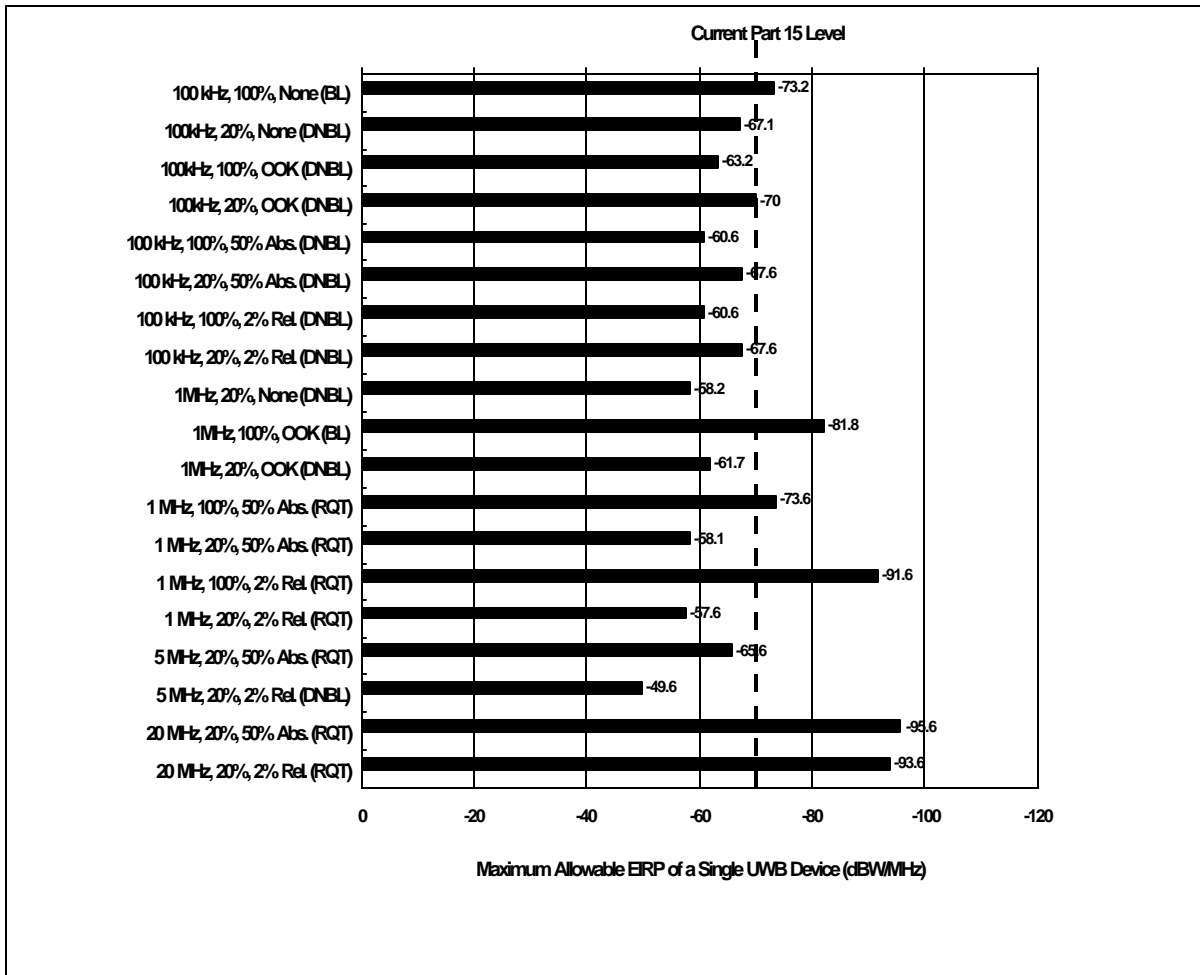
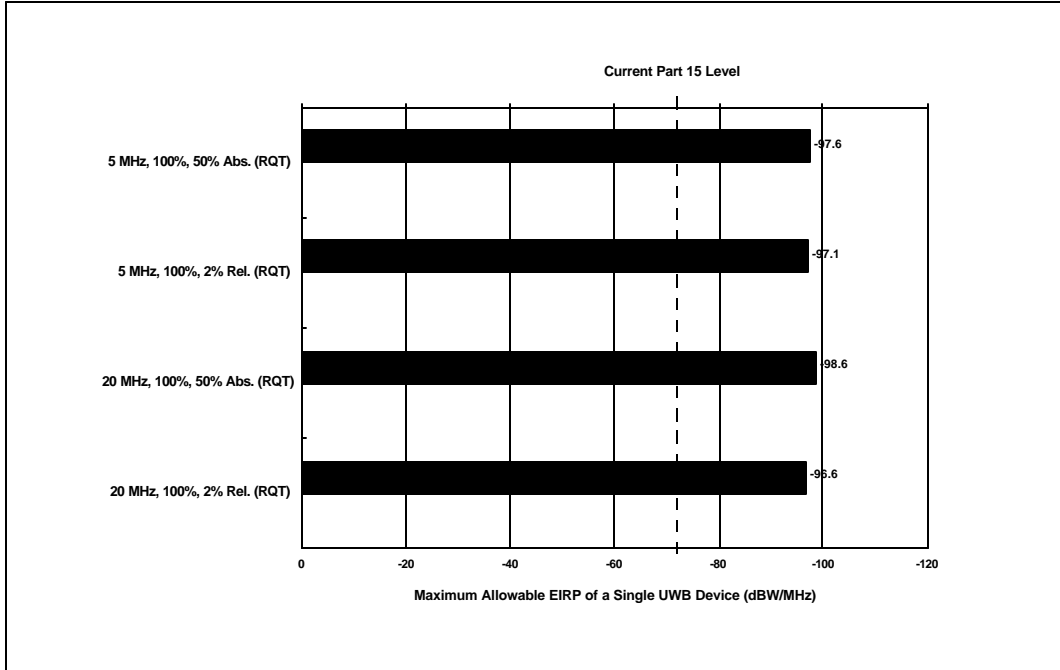
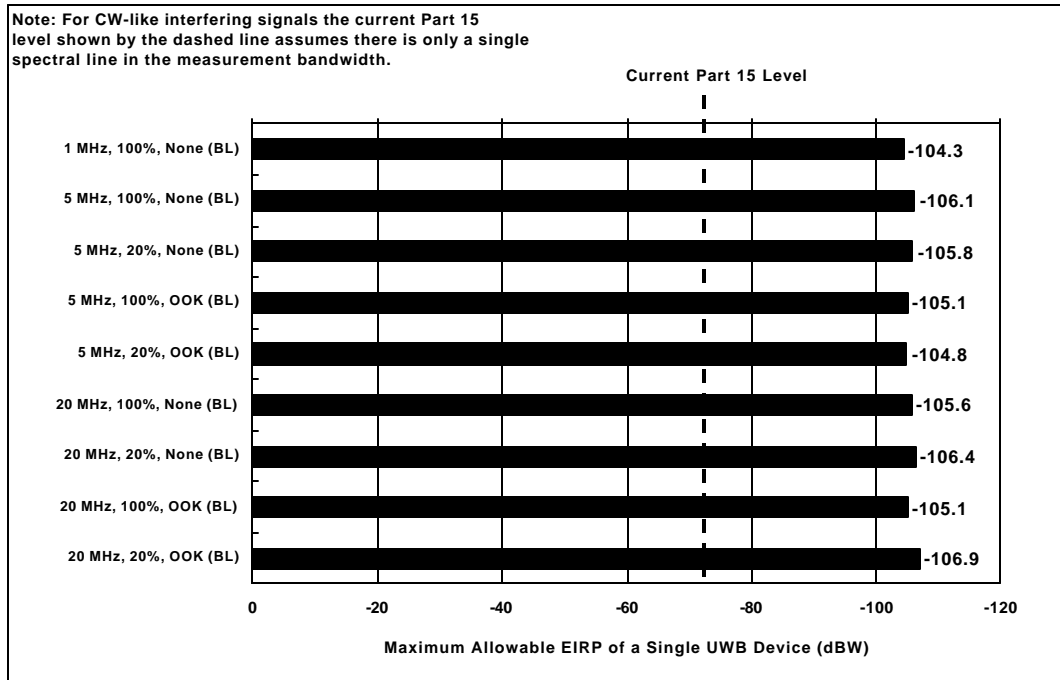


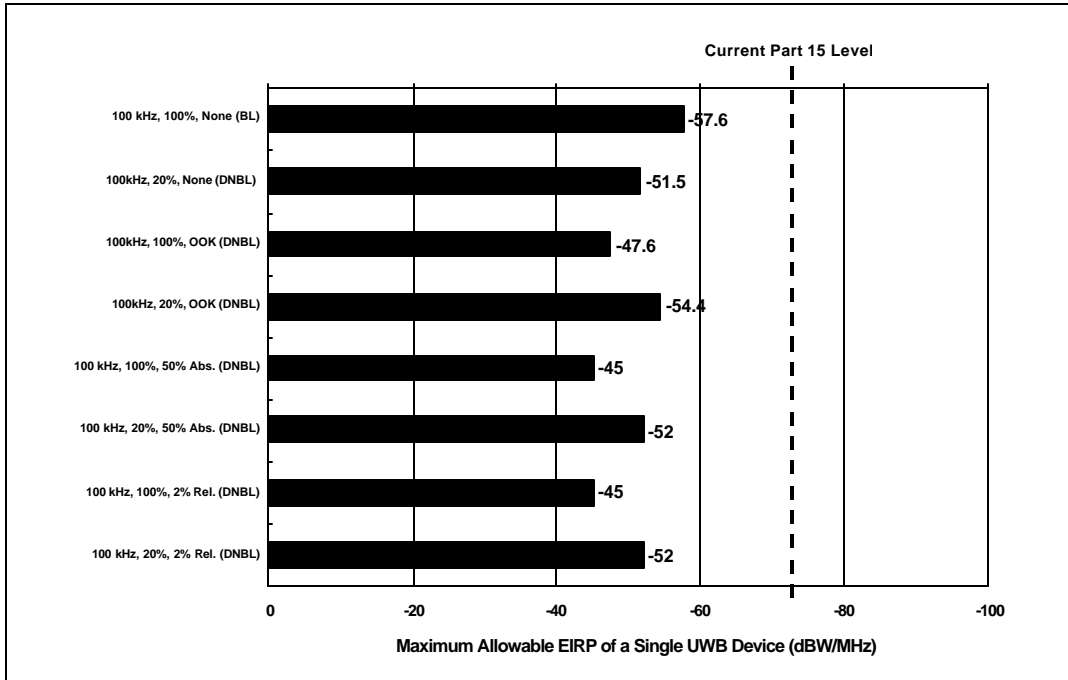
Figure 3-3. Analysis Results for Terrestrial Operational Scenario: C/A-code Receiver and Single UWB Device (Pulse-Like UWB Signals)



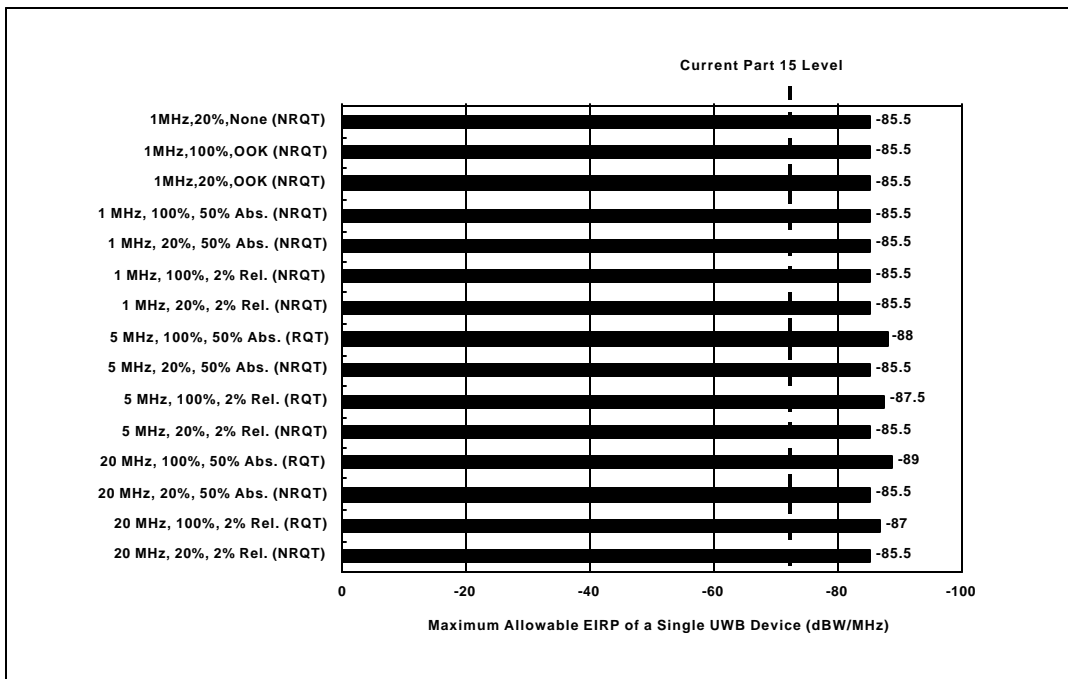
**Figure 3-4. Analysis Results for Terrestrial Operational Scenario: C/A-code Receiver and Single UWB Device (Noise-Like UWB Signals)**



**Figure 3-5. Analysis Results for Terrestrial Operational Scenario: C/A-code Receiver and Single UWB Device (CW-Like UWB Signals)**



**Figure 3-6. Analysis Results for Terrestrial Operational Scenario: C/A-code Receiver and Multiple UWB Devices - Indoor Operation (Pulse-Like UWB Signals)**



**Figure 3-7. Analysis Results for Terrestrial Operational Scenario: C/A-code Receiver and Multiple UWB Devices - Indoor Operation (Noise-Like UWB Signals)**

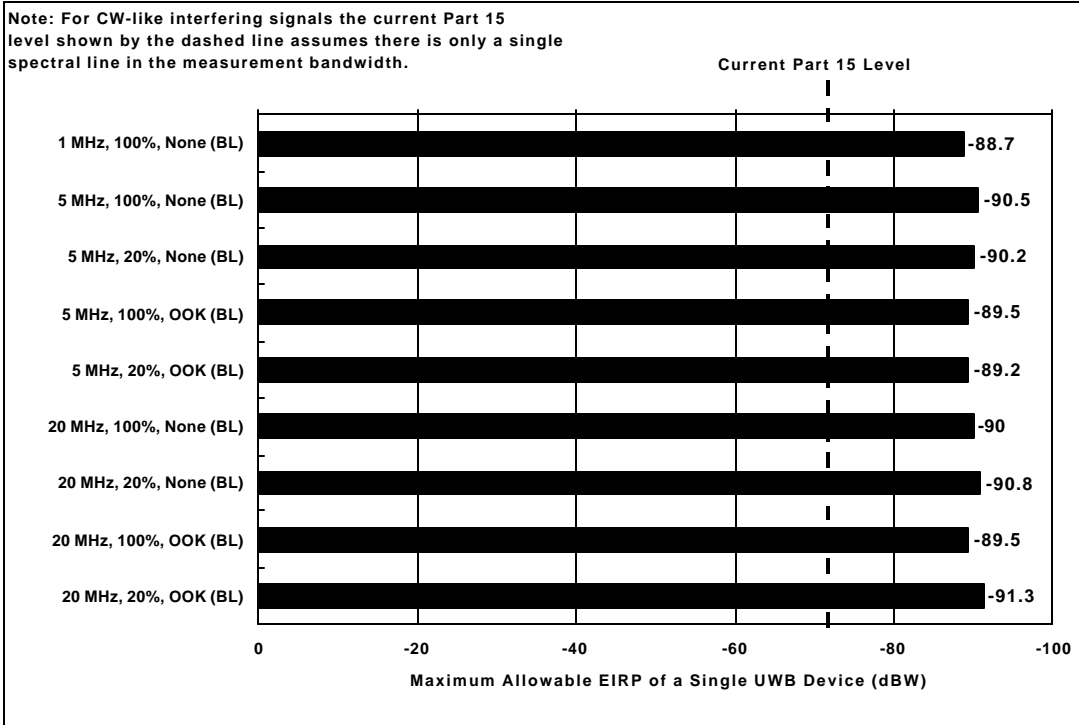


Figure 3-8. Analysis Results for Terrestrial Operational Scenario: C/A-code Receiver and Multiple UWB Devices - Indoor Operation (CW-Like UWB Signals)

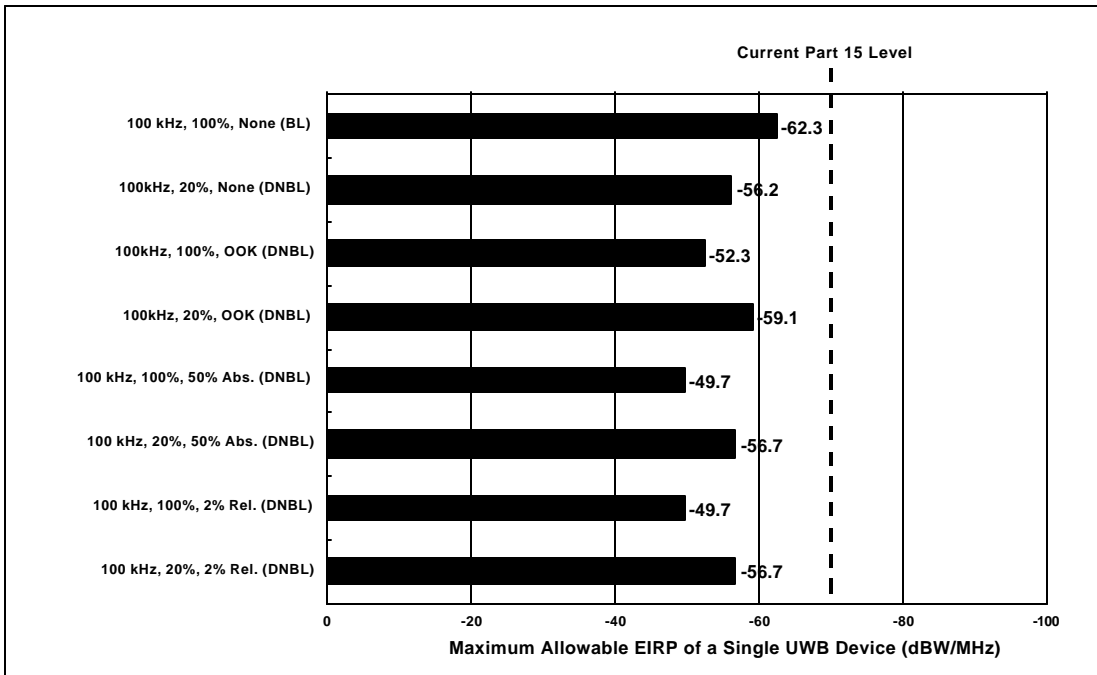


Figure 3-9. Analysis Results for Terrestrial Operational Scenario: C/A-code Receiver and Multiple UWB Devices - Outdoor Operation (Pulse-Like UWB Signals)



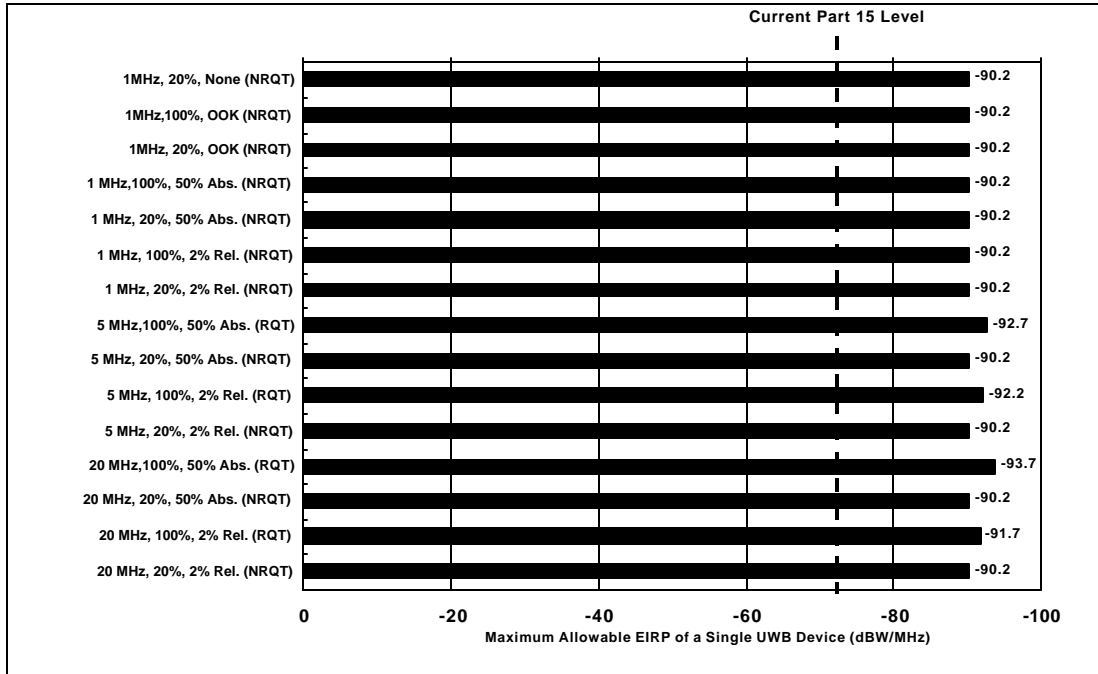


Figure 3-10. Analysis Results for Terrestrial Operational Scenario: C/A-code Receiver and Multiple UWB Devices - Outdoor Operation (Noise-Like UWB Signals)

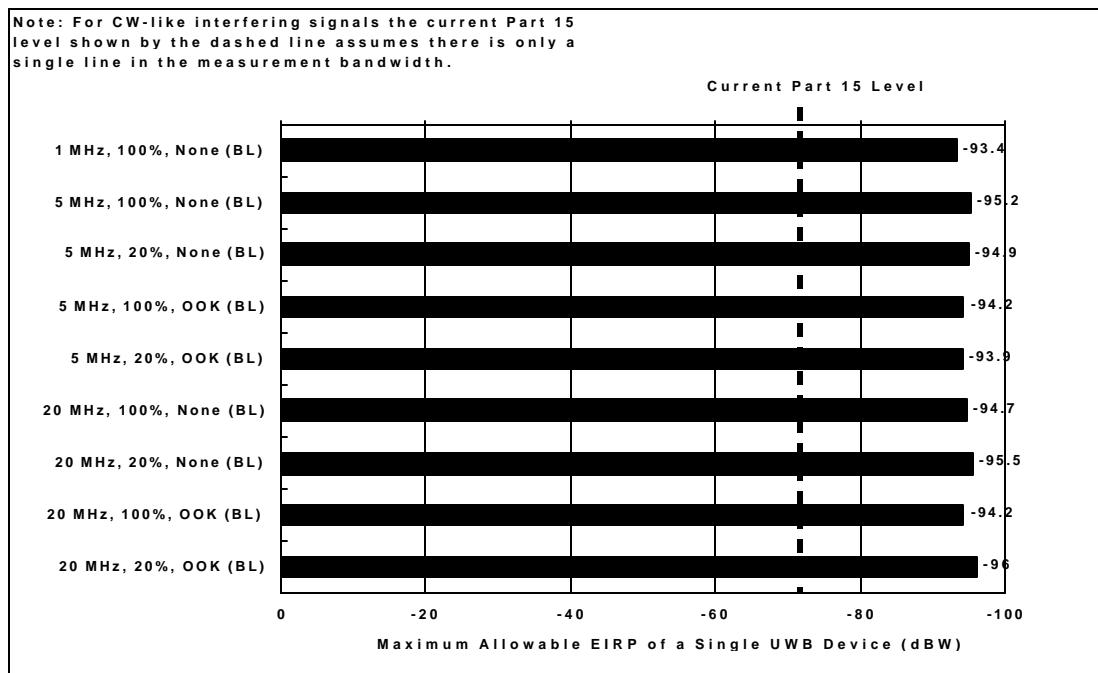
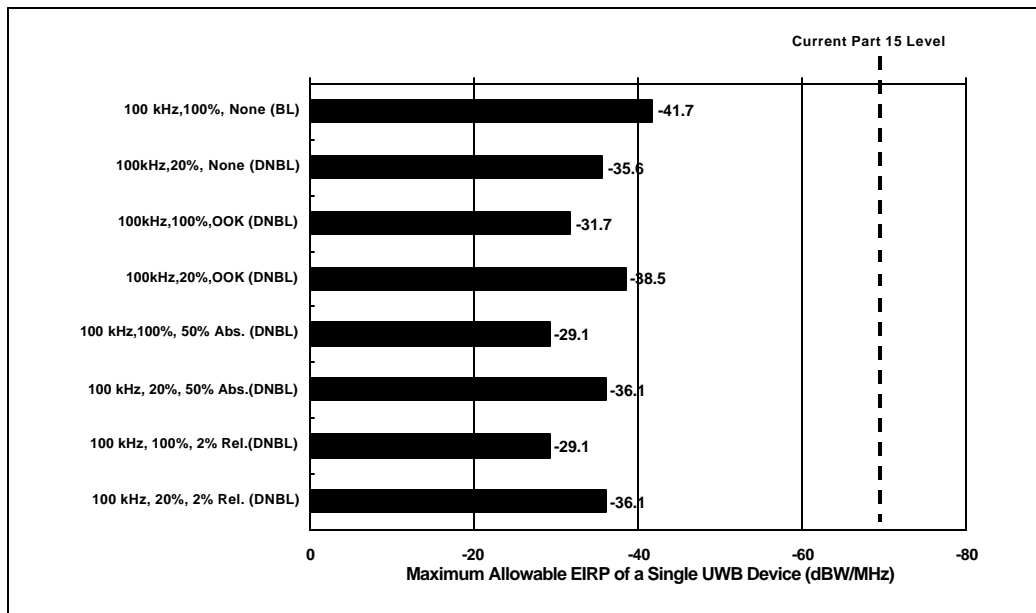


Figure 3-11. Analysis Results for Terrestrial Operational Scenario: C/A-code Receiver and Multiple UWB Devices - Outdoor Operation (CW-Like UWB Signals)

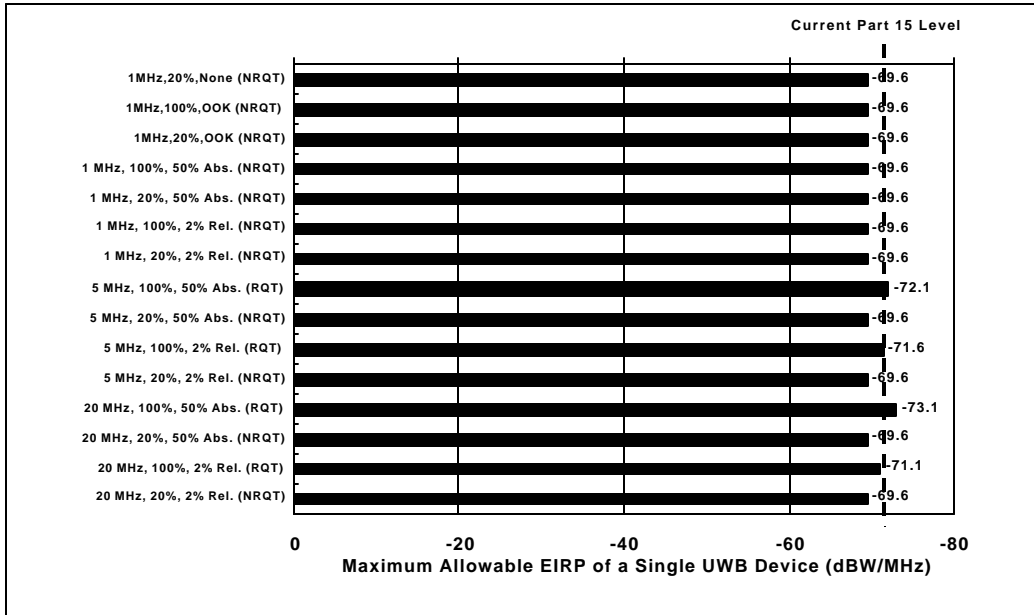
### 3.3.2 Maritime Applications

In the operational scenarios for the maritime applications, the C/A-code receiver architecture is considered. The analysis results for the C/A-code receiver architecture are given in Figures 3-12 through 3-23. Two antenna locations for the maritime use of GPS receivers were analyzed. The operational scenarios are designated as Maritime Operational Scenario I and II. The operational scenarios considered multiple UWB device interactions as well as indoor and outdoor UWB device operation. The values of maximum allowable EIRP shown in Figures 3-12 through 3-23 are for a single UWB device and are based on average power.

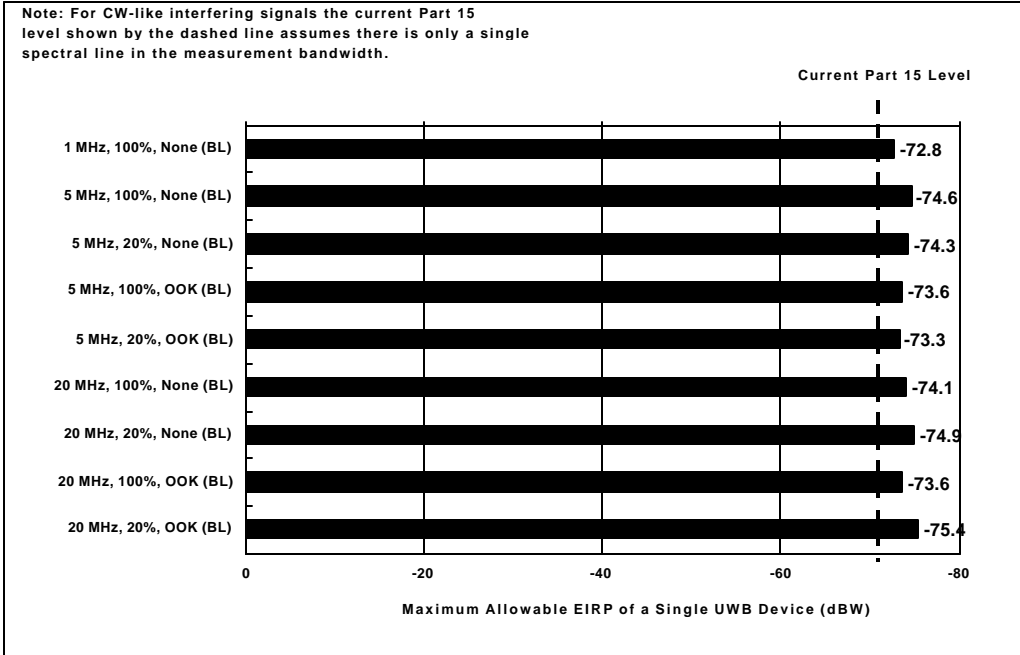
The values of maximum allowable EIRP that are required to protect the C/A-code receiver architecture considered in the maritime application operational scenarios will vary depending on the UWB signal parameters and whether the UWB devices are used indoors or outdoors. The analysis results for the operational scenarios associated with maritime applications can be discussed in terms of the characterization of the UWB signal interference effects. As shown in Figures 3-12, 3-15, 3-18, and 3-21, the values of maximum allowable EIRP for the UWB signals that have been characterized as causing pulse-like interference range from -41.7 to -26.5 dBW/MHz for indoor UWB device operation and -48.1 to -34.8 dBW/MHz for outdoor UWB device operation. Figures 3-13, 3-16, 3-19, and 3-22 show that for the UWB signals that have been characterized as causing noise-like interference, the values of maximum allowable EIRP range from -73.1 to -67.0 dBW/MHz and -79.5 to -75.3 dBW/MHz for indoor and outdoor use of UWB devices respectively. Figures 3-14, 3-17, 3-20, and 3-23 show that for the UWB signals that have been characterized as causing CW-like interference, the values of maximum allowable EIRP range from -75.4 to -70.2 dBW for indoor UWB operation and -81.8 to -78.5 dBW for outdoor UWB device operation.



**Figure 3-12. Analysis Results for Maritime Operational Scenario I: C/A-code Receiver and Multiple UWB Devices - Indoor Operation (Pulse-Like UWB Signals)**



**Figure 3-13. Analysis Results for Maritime Operational Scenario I: C/A-code Receiver and Multiple UWB Devices - Indoor Operation (Noise-Like UWB Signals)**



**Figure 3-14. Analysis Results for Maritime Operational Scenario I: C/A-code Receiver and Multiple UWB Devices - Indoor Operation (CW-Like UWB Signals)**

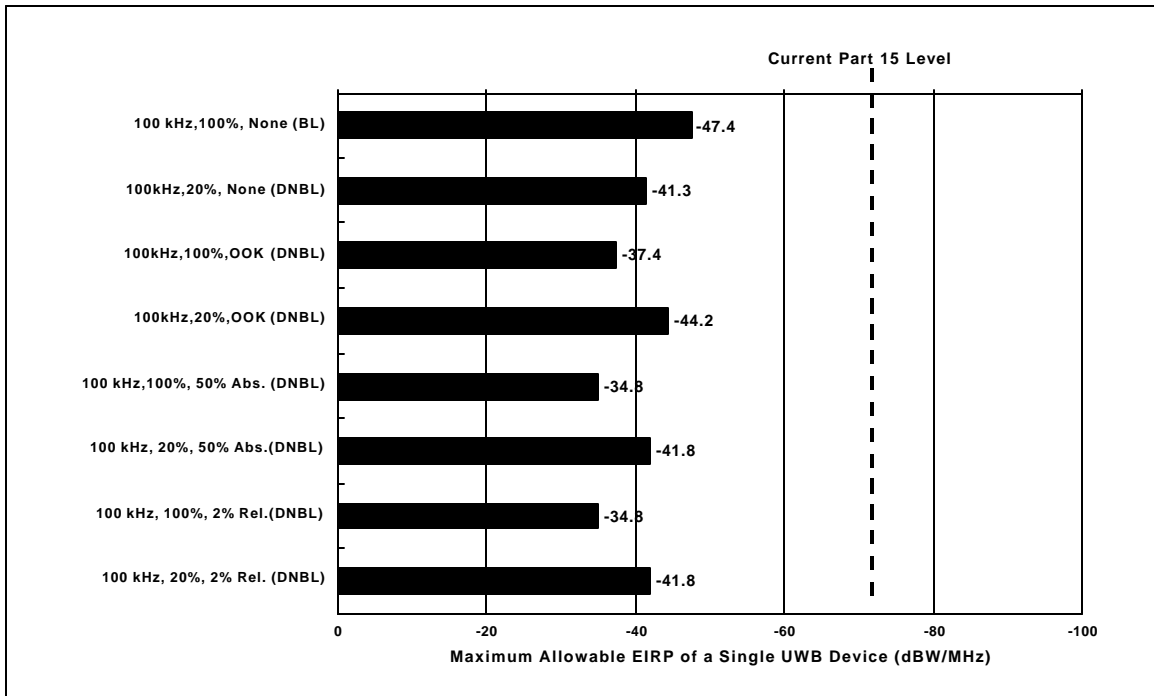


Figure 3-15. Analysis Results for Maritime Operational Scenario I: C/A-code Receiver and Multiple UWB Devices - Outdoor Operation (Pulse-Like UWB Signals)

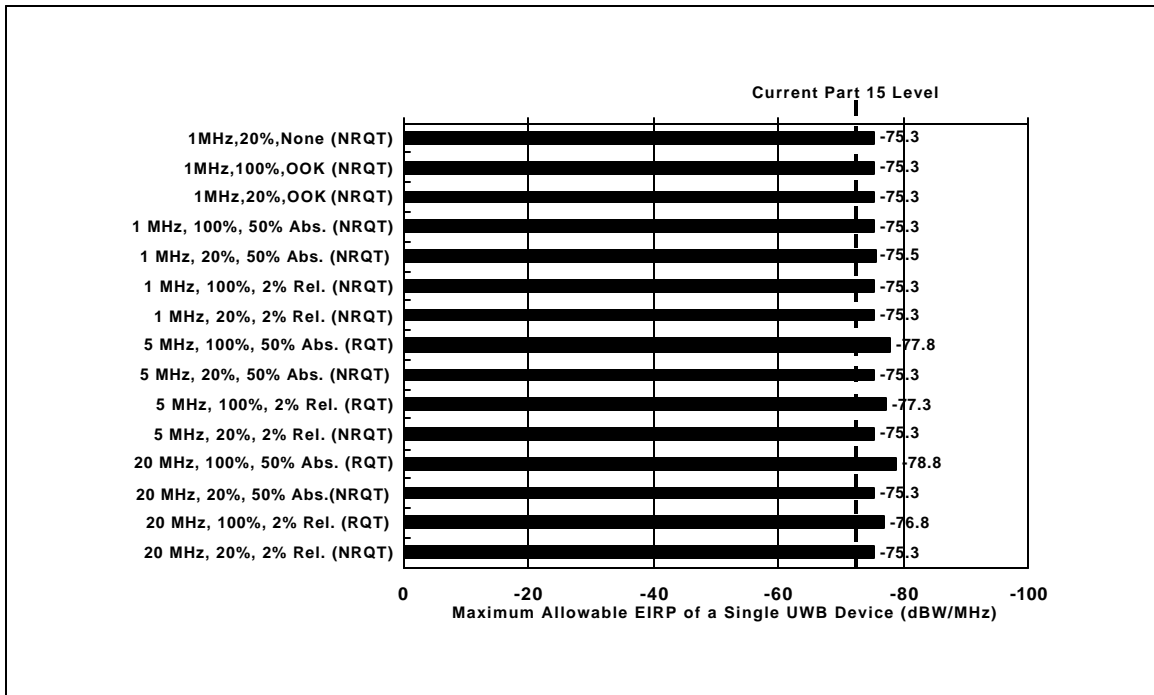


Figure 3-16. Analysis Results for Maritime Operational Scenario I: C/A-code Receiver and Multiple UWB Devices - Outdoor Operation (Noise-Like UWB Signals)

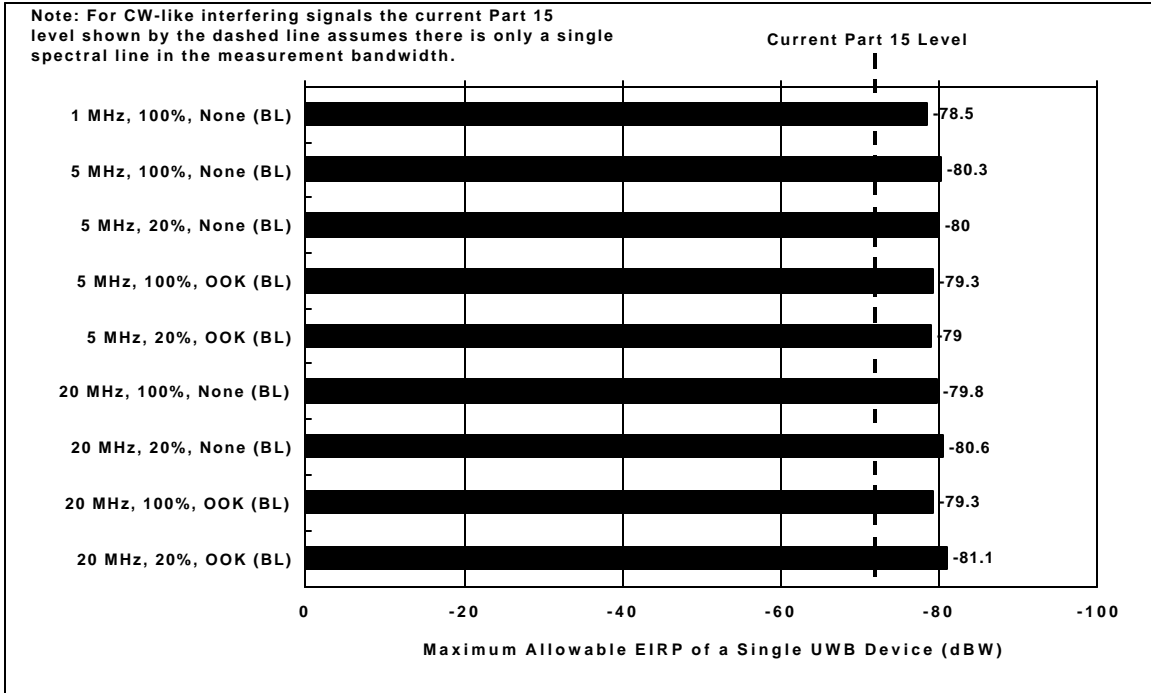


Figure 3-17. Analysis Results for Maritime Operational Scenario I: C/A-code Receiver and Multiple UWB Devices - Outdoor Operation (CW-Like UWB Signals)

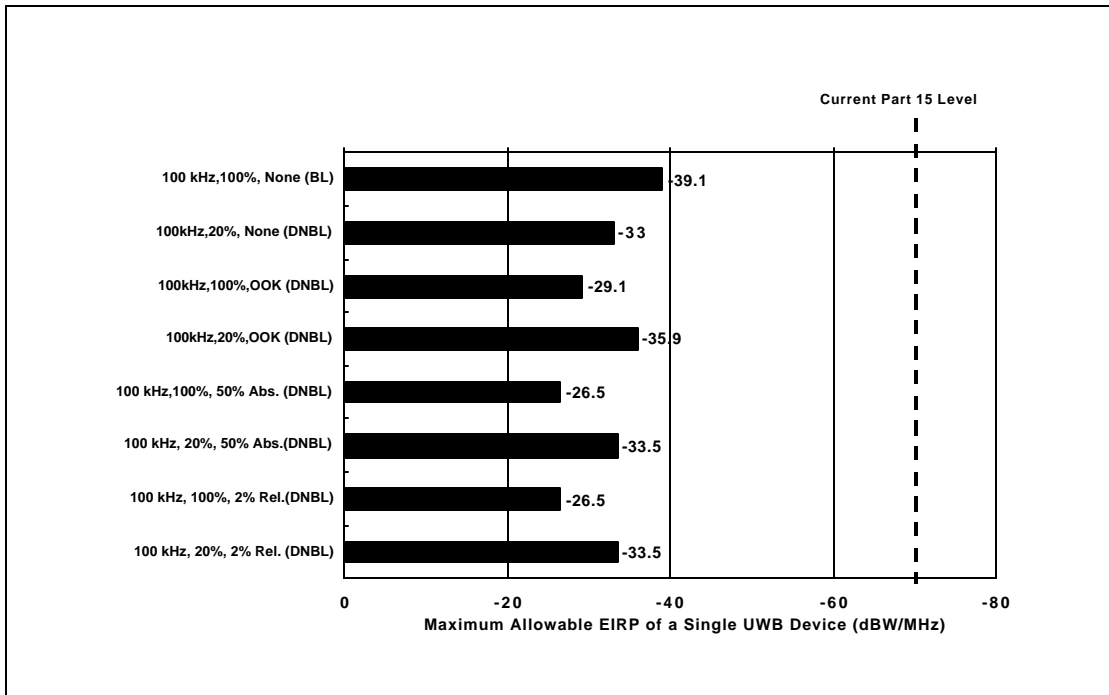
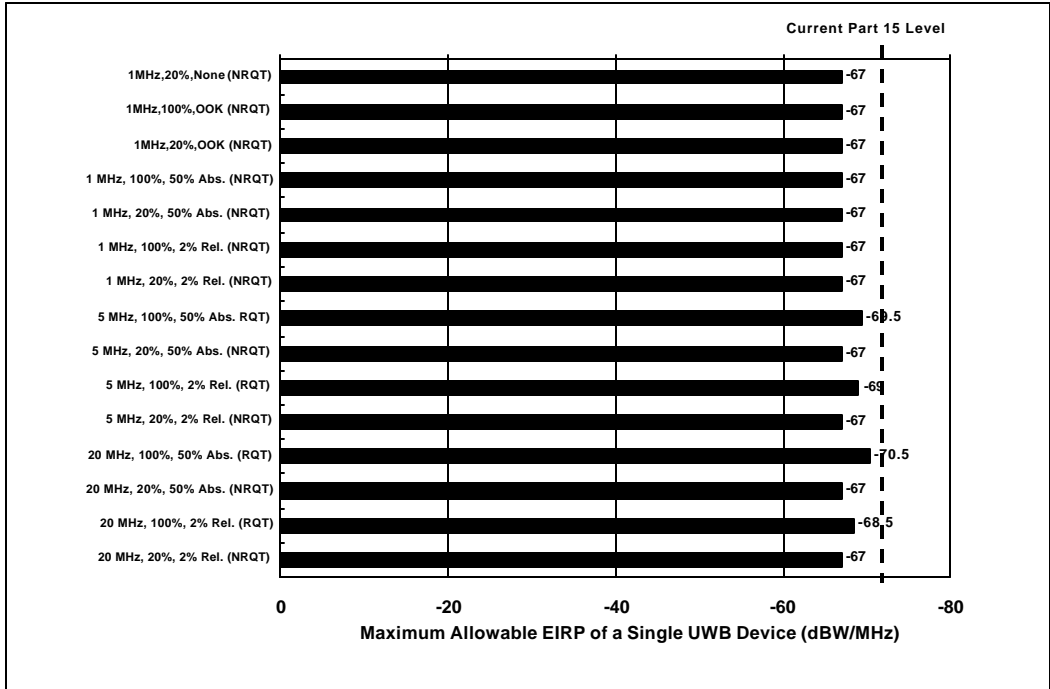
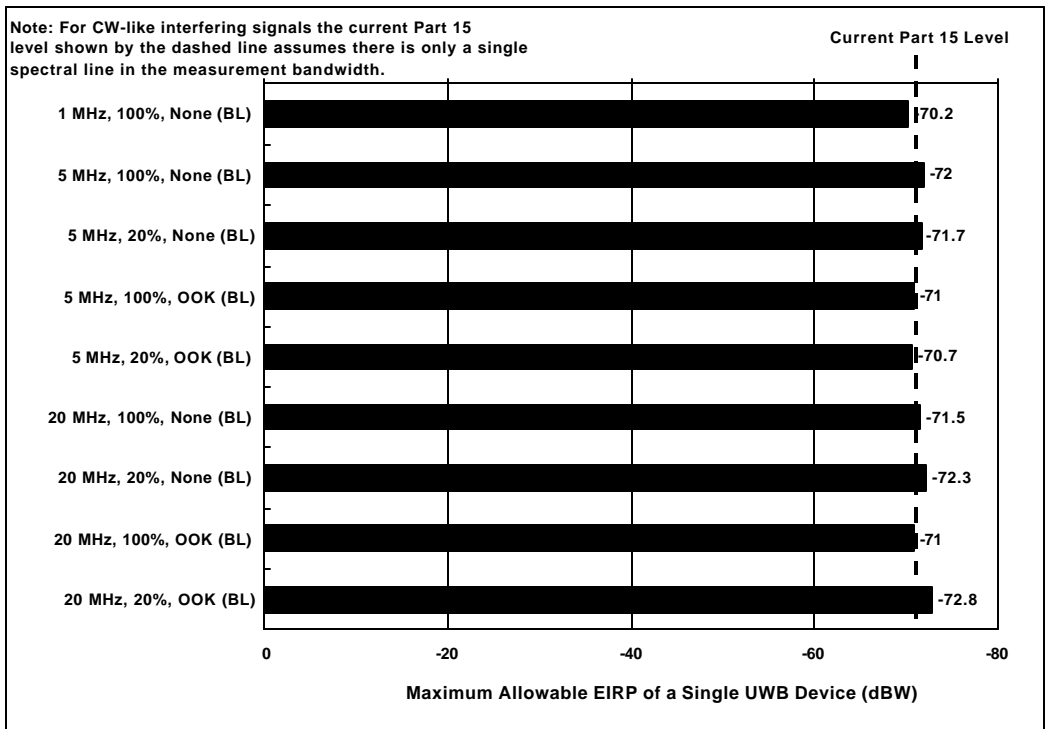


Figure 3-18. Analysis Results for Maritime Operational Scenario II: C/A-code Receiver and Multiple UWB Devices - Indoor Operation (Pulse-Like UWB Signals)



**Figure 3-19. Analysis Results for Maritime Operational Scenario II: C/A-code Receiver and Multiple UWB Devices - Indoor Operation (Noise-Like UWB Signals)**



**Figure 3-20. Analysis Results for Maritime Operational Scenario II: C/A-code Receiver and Multiple UWB Devices - Indoor Operation (CW-Like UWB Signals)**

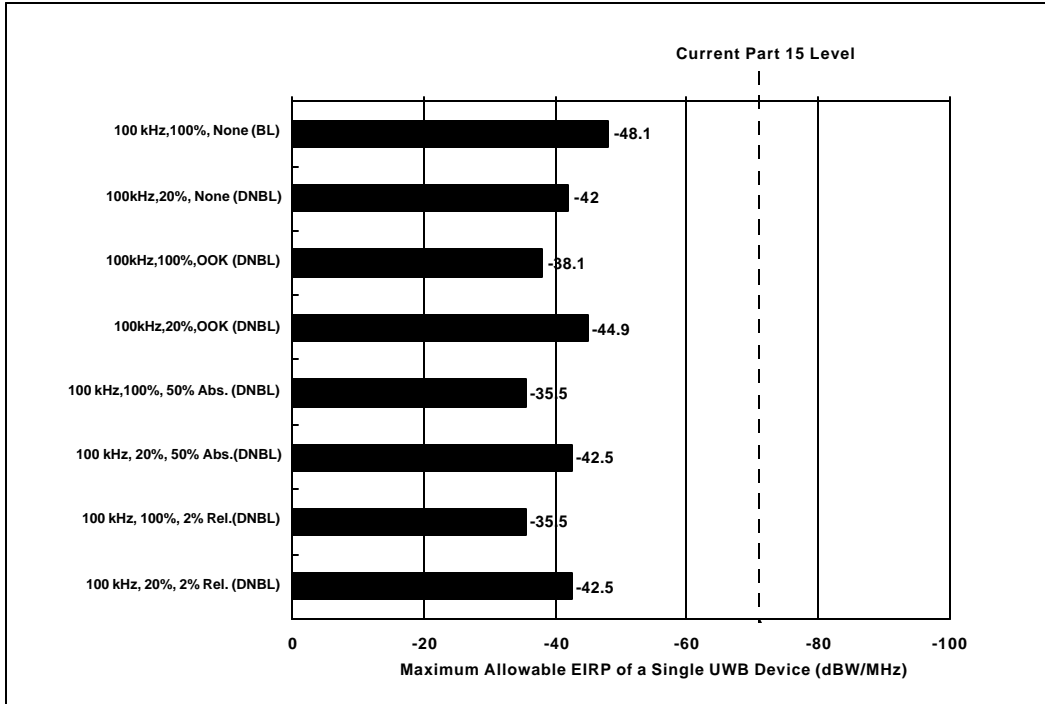


Figure 3-21. Analysis Results for Maritime Operational Scenario II: C/A-code Receiver and Multiple UWB Devices -Outdoor Operation (Pulse-Like UWB Signals)

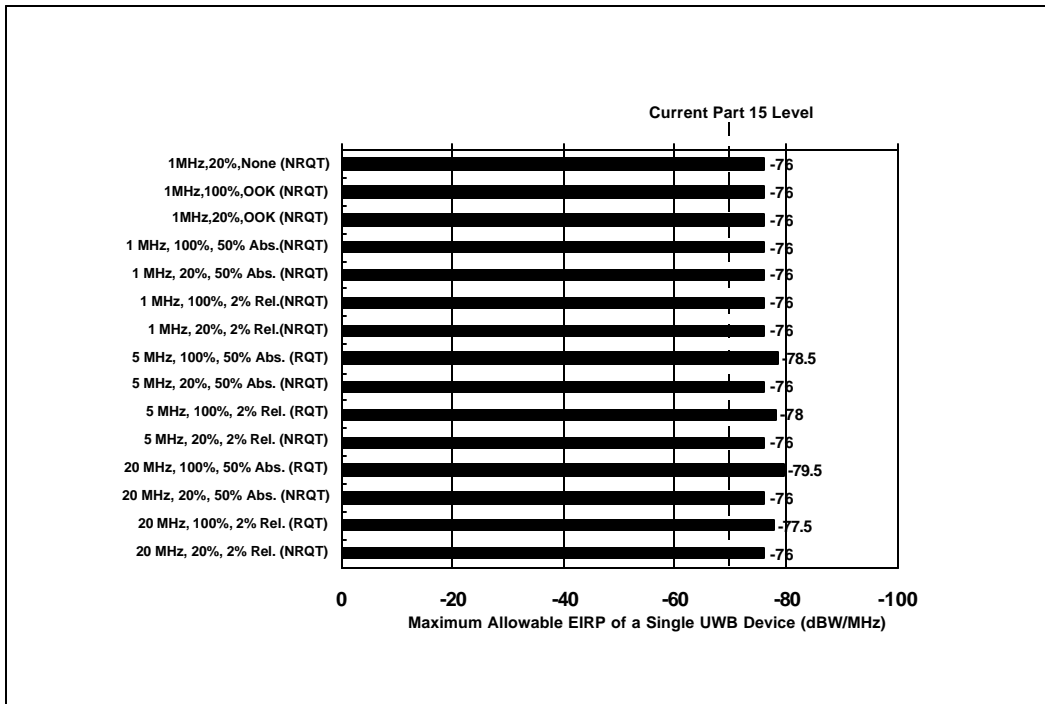
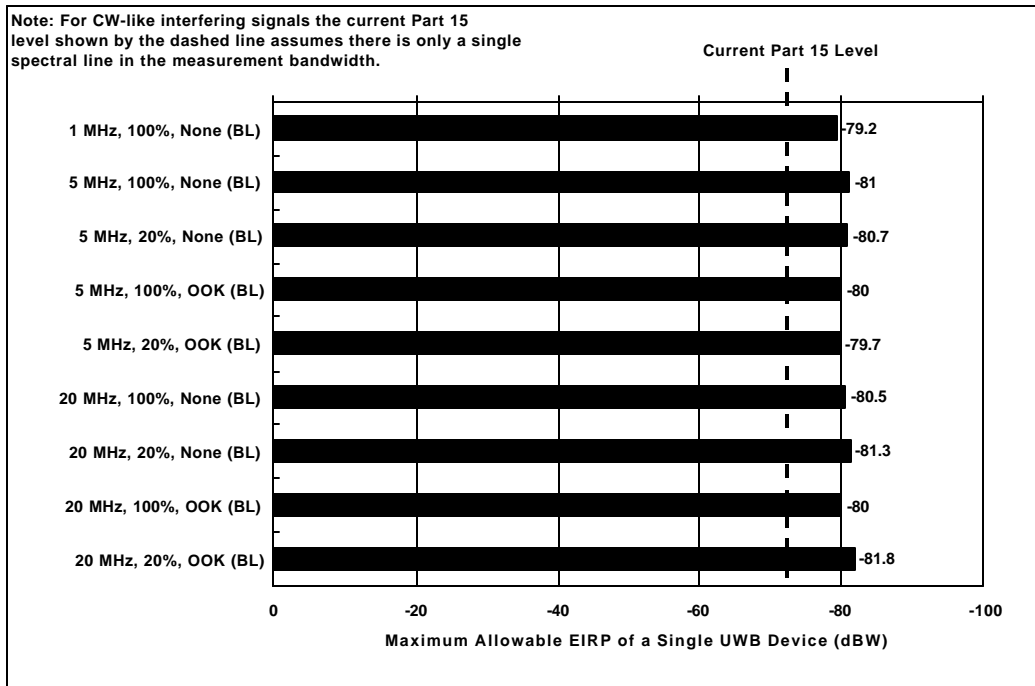


Figure 3-22. Analysis Results for Maritime Operational Scenario II: C/A-code Receiver and Multiple UWB Devices -Outdoor Operation (Noise-Like UWB Signals)



**Figure 3-23. Analysis Results for Maritime Operational Scenario II: C/A-code Receiver and Multiple UWB Devices - Outdoor Operation (CW-Like UWB Signals)**

### 3.3.3 Railway Applications

In the operational scenarios for the railway applications, the C/A-code receiver architecture is considered. The analysis results for the C/A-code receiver architecture are given in Figures 3-24 through 3-29. The operational scenarios considered multiple UWB device interactions as well as indoor and outdoor UWB device operation. The values of maximum allowable EIRP shown in Figures 3-24 through 3-29 are for a single UWB device and are based on average power.

The values of maximum allowable EIRP that are required to protect the C/A-code receiver architecture considered in the railway operational scenarios will vary depending on the UWB signal parameters and whether the UWB devices are being used indoors or outdoors. The analysis results can be discussed in terms of the characterization of the UWB signal interference effects. As shown in Figures 3-24 and 3-27, the values of maximum allowable EIRP for UWB signals that have been characterized as causing pulse-like interference range from -56.3 to -43.7 dBW/MHz for indoor UWB device operation and -57.8 to -45.2 dBW/MHz for outdoor UWB device operation. Figures 3-25 and 3-28 show that for UWB signals that have been characterized as causing noise-like interference, the values of maximum allowable EIRP range from -86.5 to -83.0 dBW/MHz for indoor UWB device operation and -88 to -84.5 dBW/MHz for outdoor UWB device operation. Figures 3-26 and 3-29 show that for UWB signals that have been characterized as causing CW-like interference, the values of maximum allowable EIRP range from -90 to -87.4 dBW for indoor UWB device operation and -91.5 to -88.9 dBW for outdoor UWB device operation.



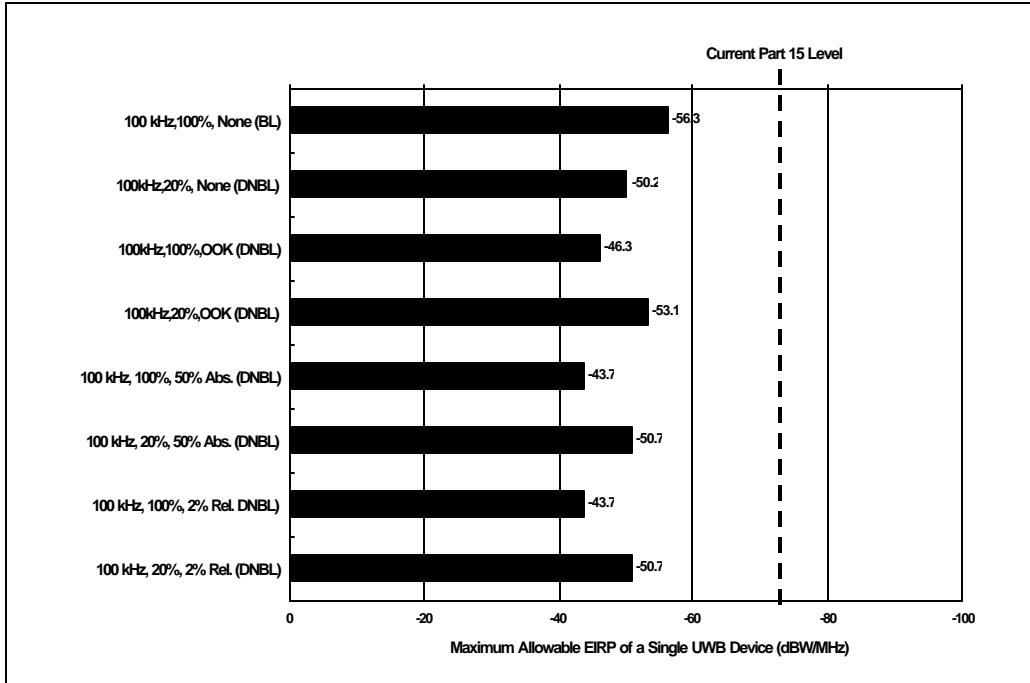


Figure 3-24. Analysis Results for Railway Operational Scenario: C/A-code Receiver and Multiple UWB Devices -Indoor Operation (Pulse-Like UWB Signals)

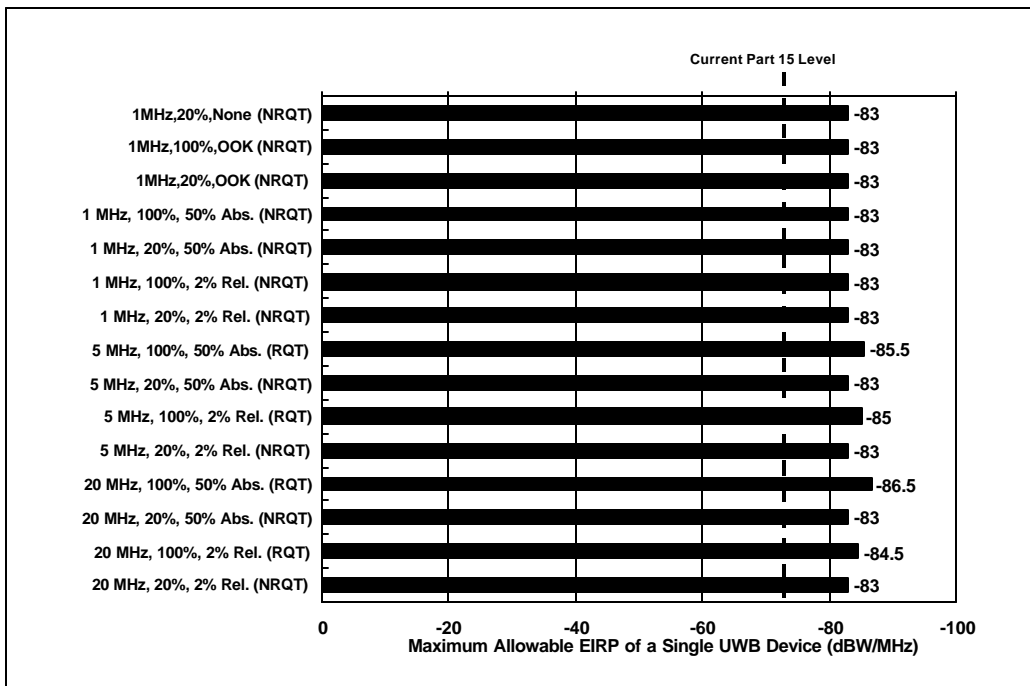


Figure 3-25. Analysis Results for Railway Operational Scenario: C/A-code Receiver and Multiple UWB Devices -Indoor Operation (Noise-Like UWB Signals)

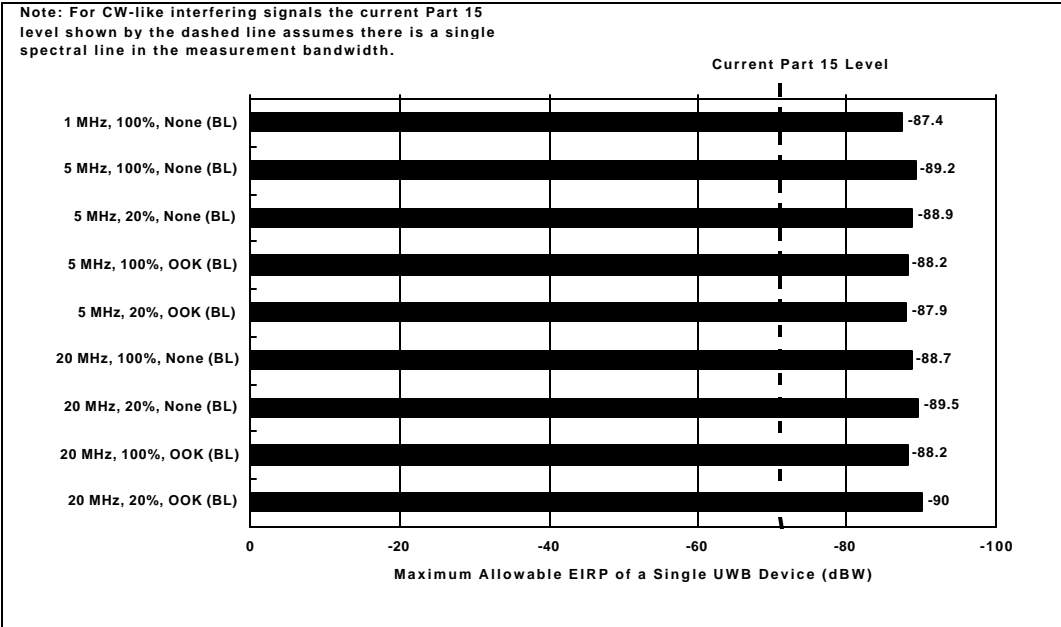


Figure 3-26. Analysis Results for Railway Operational Scenario: C/A-code Receiver and Multiple UWB Devices - Indoor Operation (CW-Like UWB Signals)

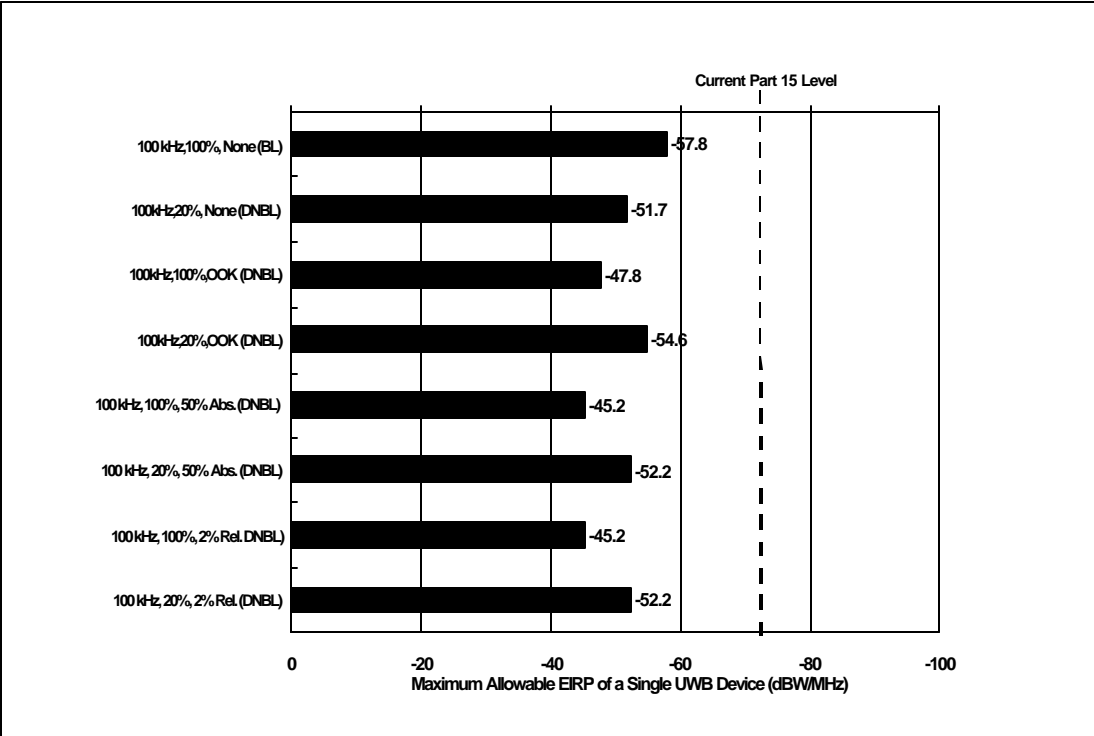


Figure 3-27. Analysis Results for Railway Operational Scenario: C/A-code Receiver and Multiple UWB Devices - Outdoor Operation (Pulse-Like UWB Signals)

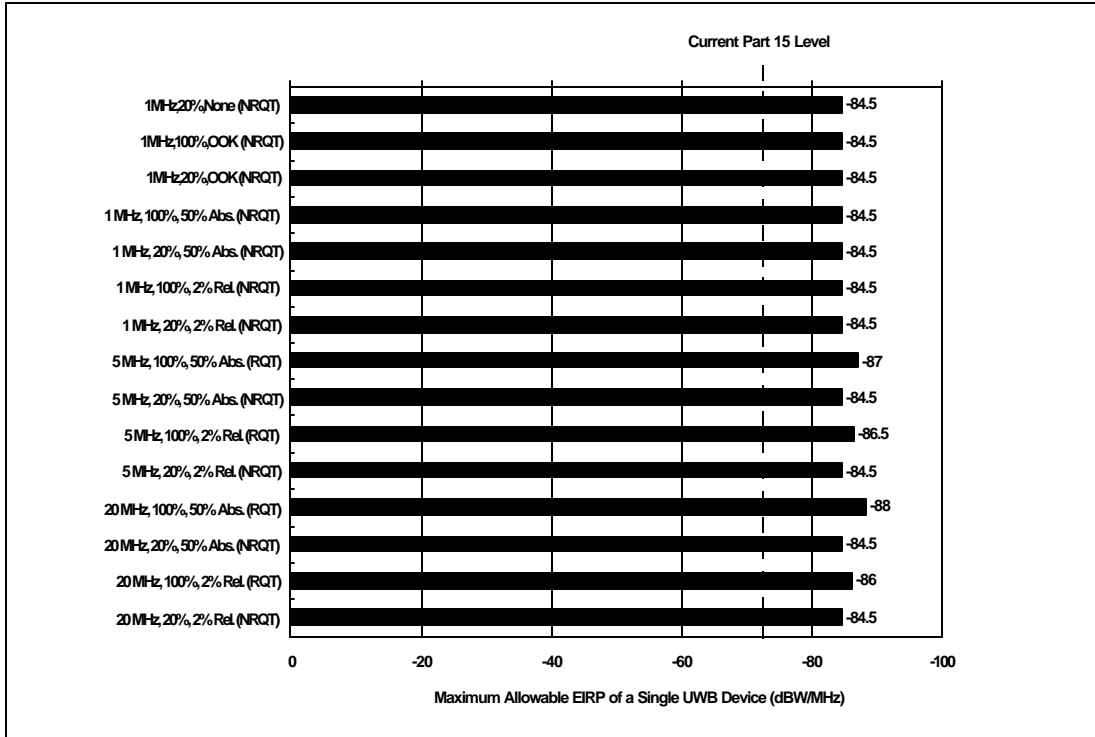


Figure 3-28. Analysis Results for Railway Operational Scenario: C/A-code Receiver and Multiple UWB Devices - Outdoor Operation (Noise-Like UWB Signals)

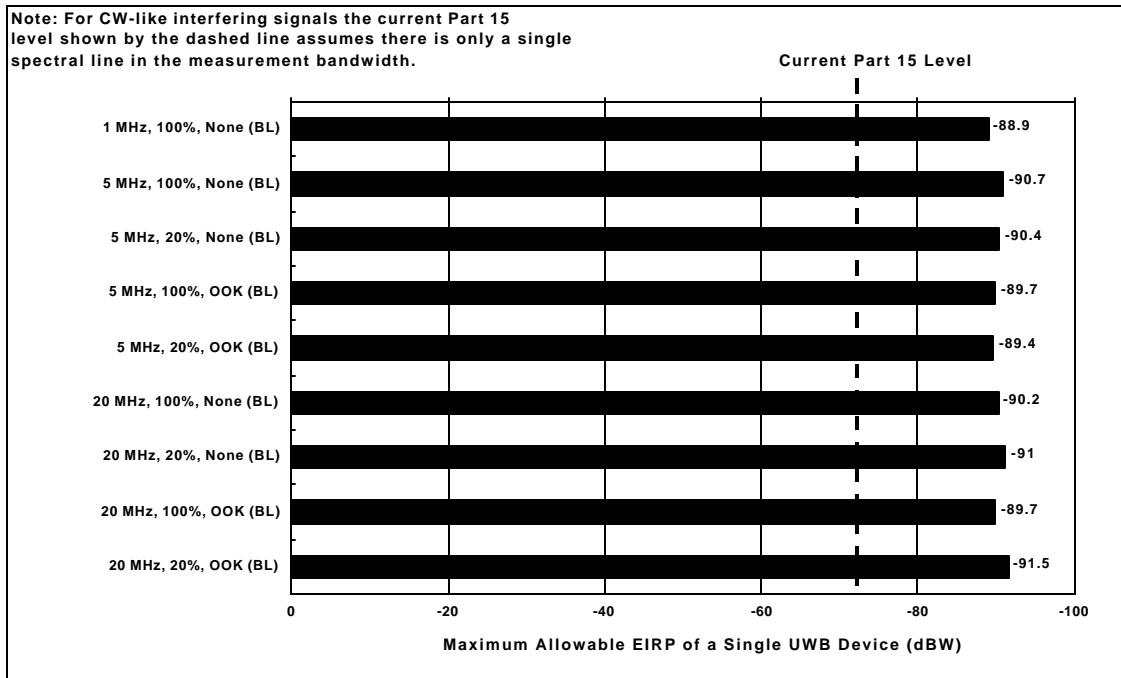


Figure 3-29. Analysis Results for Railway Operational Scenario: C/A-code Receiver and Multiple UWB Devices - Outdoor Operation (CW-Like UWB Signals)

### 3.3.4 Surveying Applications

In the operational scenarios for the surveying applications, the semi-codeless receiver architecture is considered. The analysis results are given in Figures 3-30 through 3-33. The operational scenarios considered single and multiple UWB device interactions. The values of maximum allowable EIRP shown in Figures 3-30 through 3-33 are for a single UWB device and are based on average power. For the semi-codeless receiver architecture the UWB signals have been characterized as causing pulse-like or noise-like interference. As shown in Figures 3-30 and 3-31, the values of maximum allowable EIRP range from -94.1 to -55.1 dBW/MHz for single UWB device interactions. For multiple UWB device interactions, Figures 3-32 and 3-33 show that the values of maximum allowable EIRP range from -94.2 to -55.2 dBW/MHz.

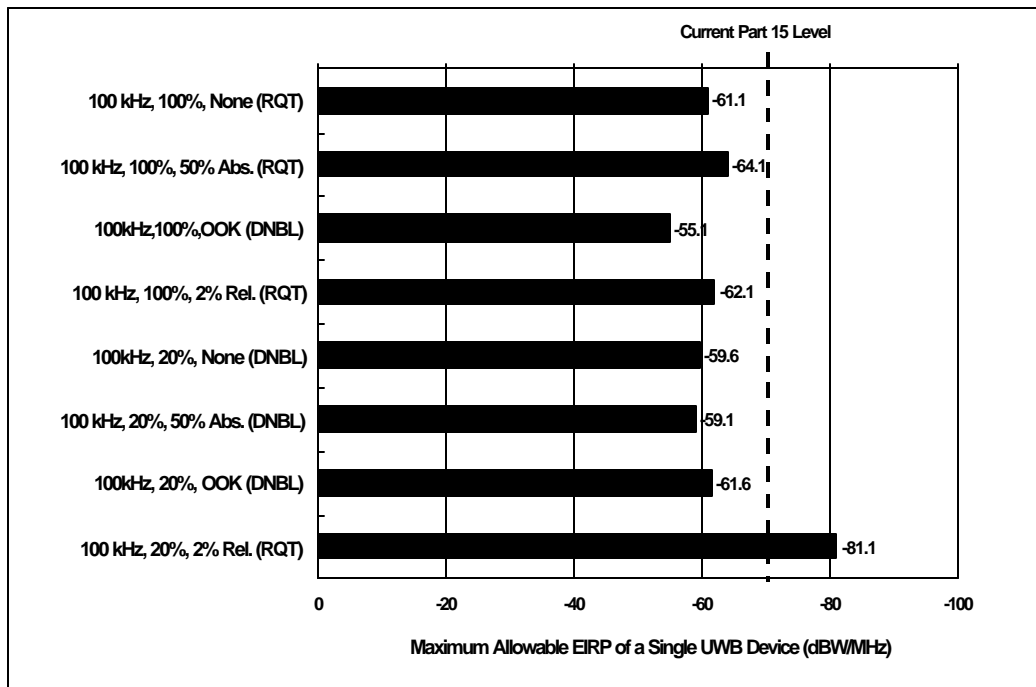


Figure 3-30. Analysis Results for the Surveying Operational Scenario: Semi-Codeless Receiver and Single UWB Device (Pulse-Like UWB Signals)

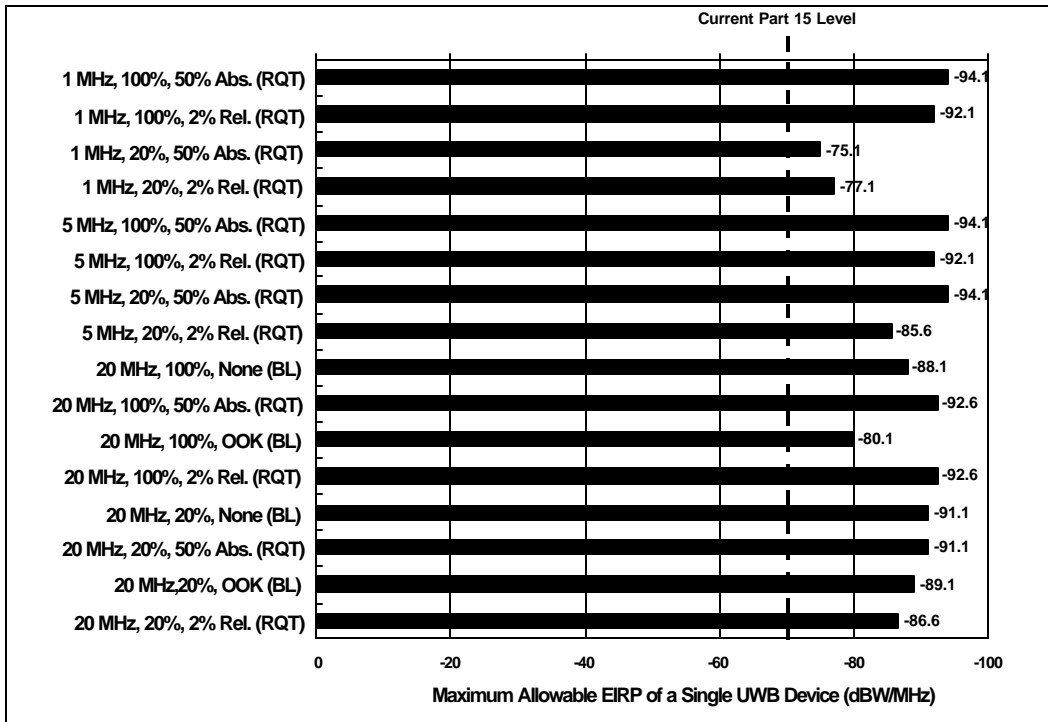


Figure 3-31. Analysis Results for the Surveying Operational Scenario: Semi-Codeless Receiver and Single UWB Device (Noise-Like UWB Signals)

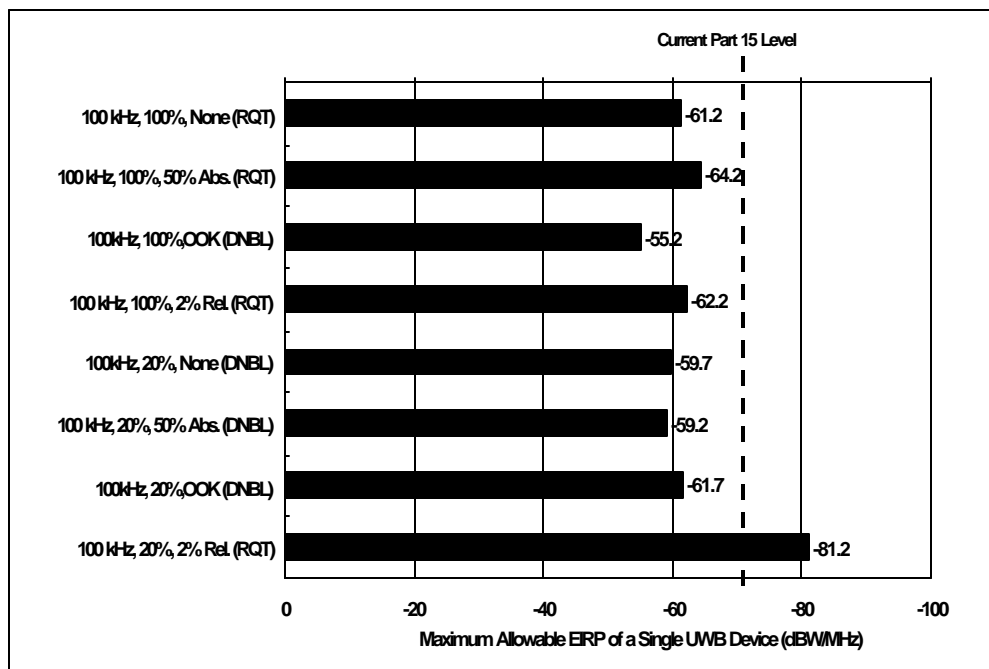


Figure 3-32. Analysis Results for Surveying Operational Scenario: Semi-Codeless Receiver and Multiple UWB Devices (Pulse-Like UWB Signals)

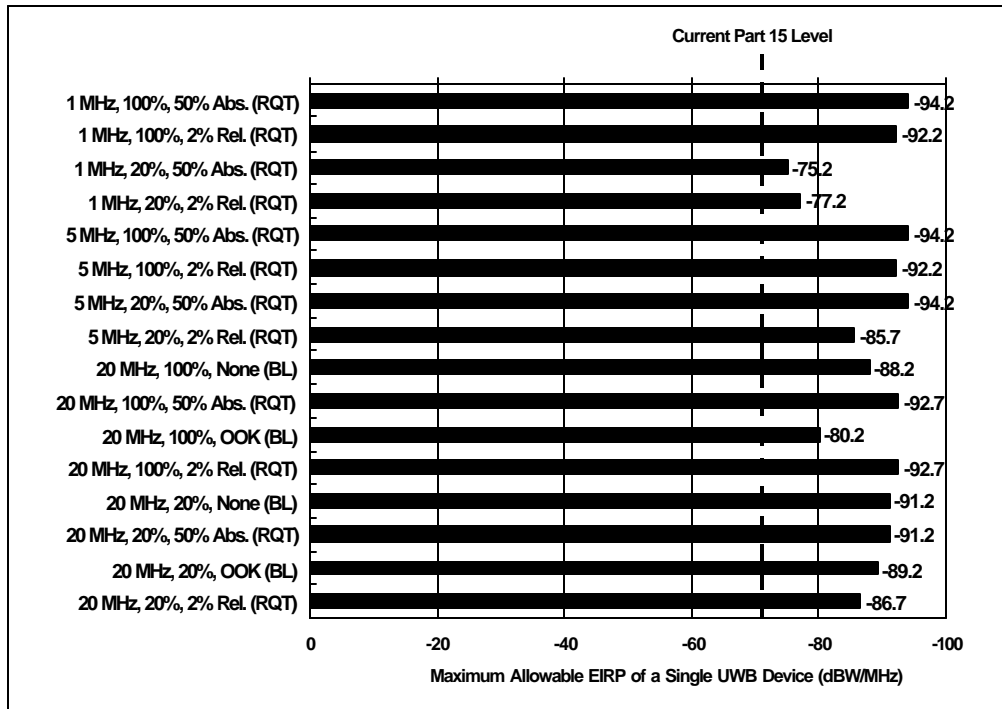


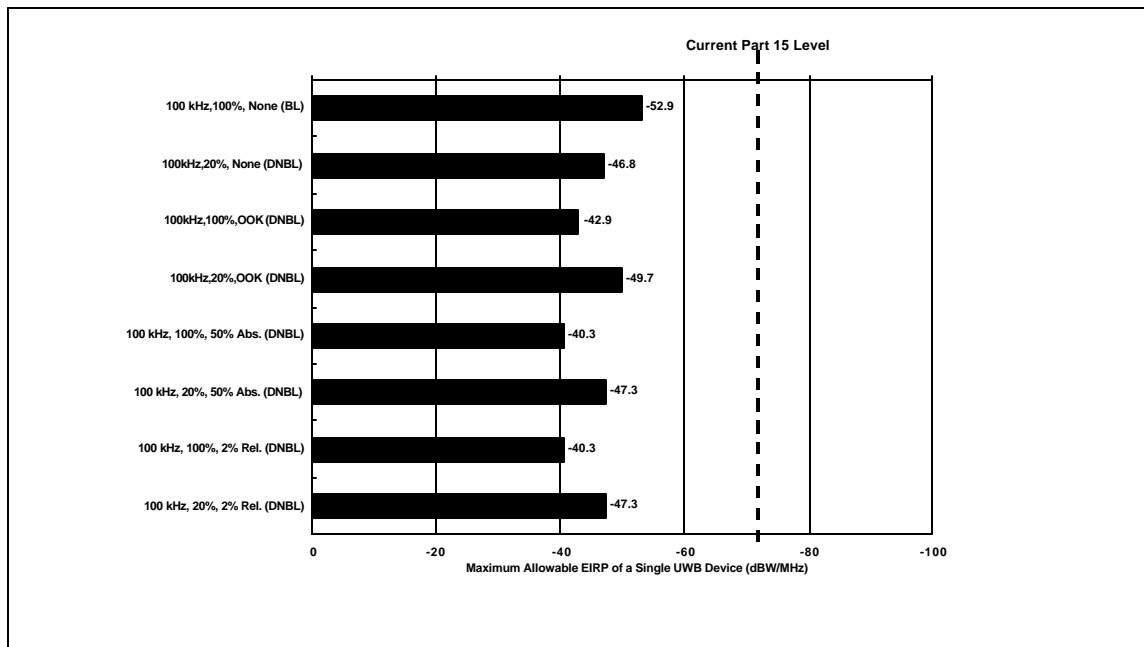
Figure 3-33. Analysis Results for the Surveying Operational Scenario: Semi-Codeless Receiver and Multiple UWB Devices (Noise-Like UWB Signals)

### 3.3.5 Aviation Applications

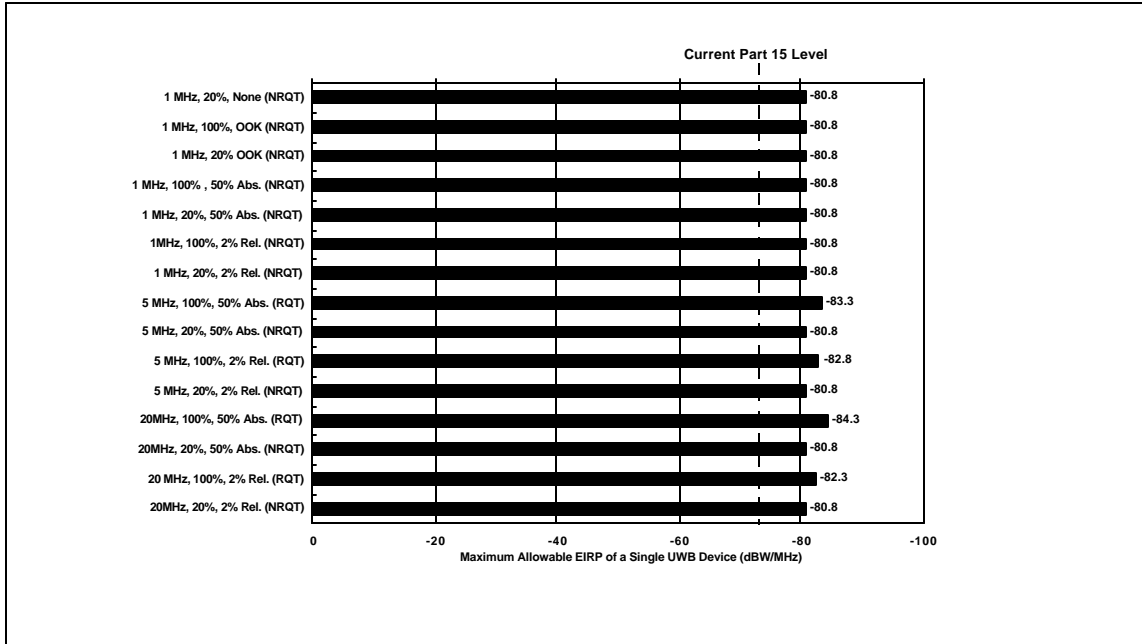
In the aviation non-precision approach landing operational scenario, the C/A-code receiver architecture is considered. The analysis results for the C/A-code receiver architecture are given in Figures 3-34, 3-35, and 3-36. The values of maximum allowable EIRP shown in Figures 3-34 through 3-36 are for a single UWB device and are based on average power. As shown in Figure 3-34, for UWB signals that have been characterized as causing pulse-like interference, the values of maximum allowable EIRP range from -52.9 to -40.3 dBW/MHz. For UWB signals that have been characterized as causing noise-like interference, Figure 3-35 shows that the values of maximum allowable EIRP range from -84.3 to -80.8 dBW/MHz. As shown in Figure 3-36, the values of maximum allowable EIRP for UWB signals that have been characterized as causing CW-like interference range from -86.6 to -84 dBW.

In the aviation en-route navigation operational scenario, the C/A-code receiver architecture is considered. The analysis results for the C/A-code receiver architecture are given in Figures 3-37 and 3-38. The analysis results are presented in terms of the maximum EIRP as a function of active UWB device density. In this operational scenario, the aircraft is at an altitude of 1,000 feet. The operational scenarios consider both the indoor and outdoor operation of UWB devices. In this operational scenario it is assumed that there is a large enough number of UWB devices, such that independent of the parameters of the individual UWB signals the aggregate effect causes noise-like interference. The values of maximum

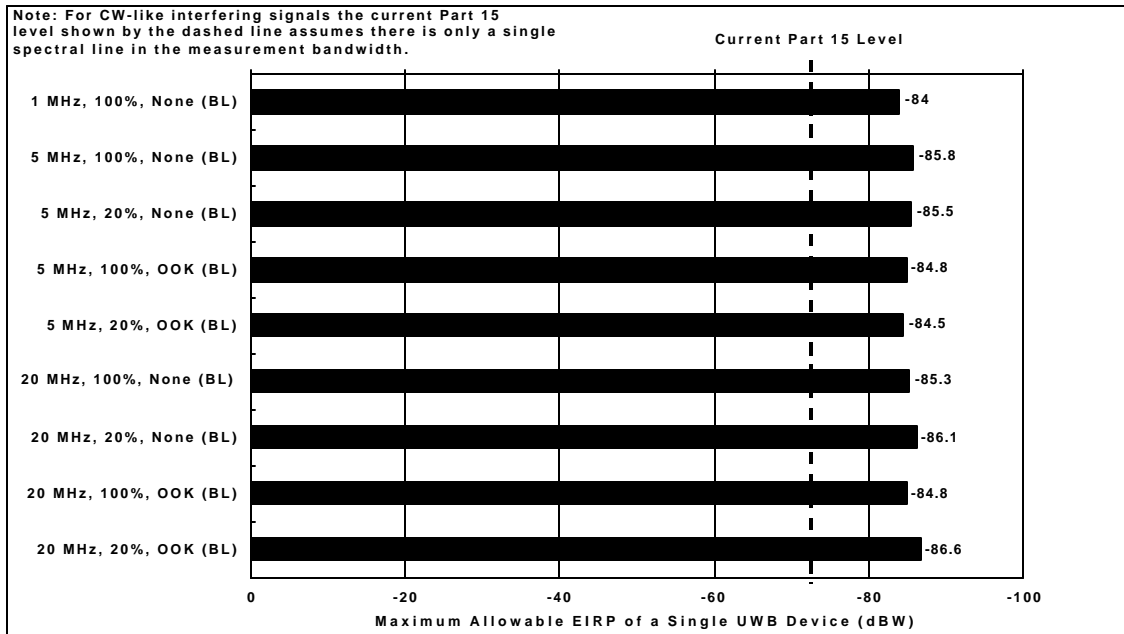
allowable EIRP shown in Figures 3-37 and 3-38 are for a single UWB device and are based on average power. Figure 3-37 shows the analysis results when all of the UWB devices are operating outdoor. Figure 3-38 shows the analysis results when all of the UWB devices are operating indoors. As discussed earlier, determining the active number of UWB devices to consider when establishing the maximum allowable EIRP level is difficult and depends on factors such as population, the rate of penetration of the technology, and the appropriate activity factor. For example, assuming a population density of 2000 people per square kilometer and an assumed technology penetration of 10%, the UWB device density would be 200 devices per square kilometer. Based on this UWB device density, the EIRP of a single UWB device would be -76.6 dBW/MHz for indoor UWB device operation (Figure 3-37) and -85.6 dBW/MHz for outdoor UWB device operation (Figure 3-38). These values of maximum allowable EIRP assume that the UWB devices are transmitting simultaneously. An appropriate value for the activity factor could also be considered, depending on the UWB device application.



**Figure 3-34. Analysis Results for Aviation (Non-Precision Approach Landing) Operational Scenario: C/A-code Receiver and Multiple UWB Devices (Pulse-Like UWB Signals)**



**Figure 3-35. Analysis Results for Aviation (Non-Precision Approach Landing) Operational Scenario: C/A-code Receiver and Multiple UWB Devices (Noise-Like UWB Signals)**



**Figure 3-36. Analysis Results for Aviation (Non-Precision Approach Landing) Operational Scenario: C/A-code Receiver and Multiple UWB Devices (CW-Like UWB Signals)**



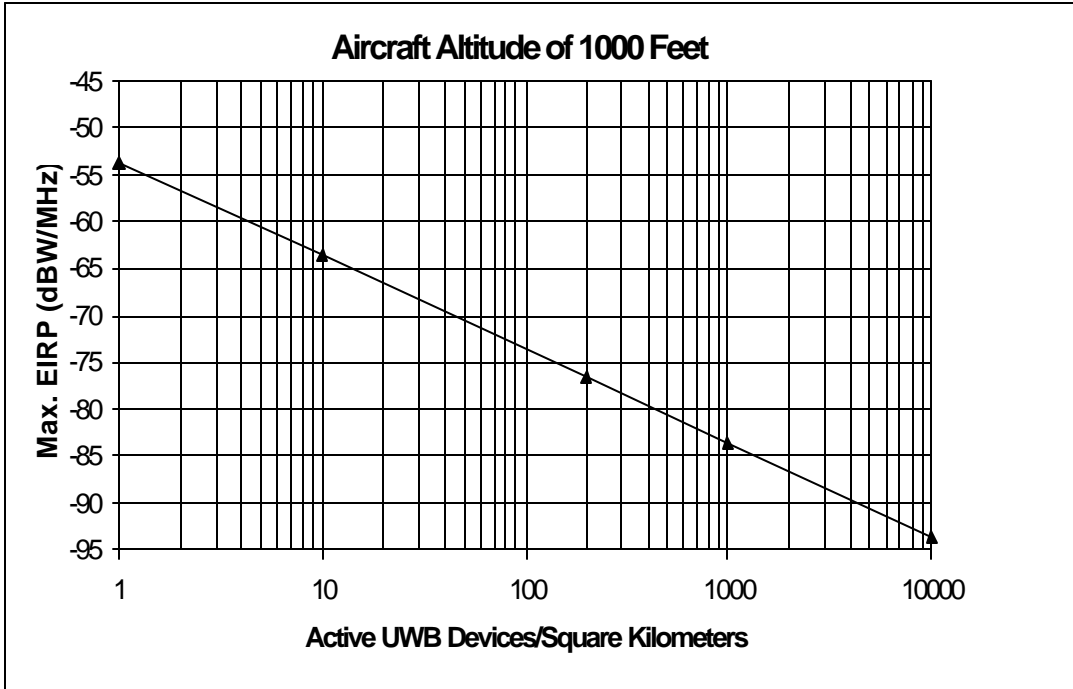


Figure 3-37. Analysis Results for Aviation (En-Route Navigation) Operational Scenario: C/A-code Receiver and Multiple UWB Devices - Outdoor Operation

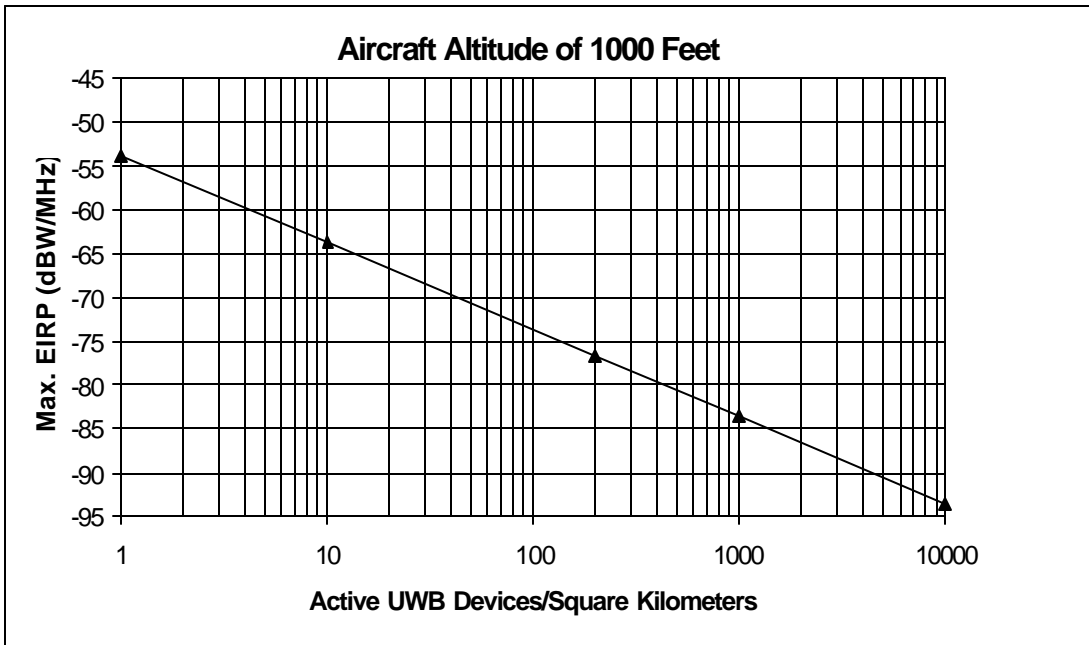


Figure 3-38. Analysis Results for Aviation (En-Route Navigation) Operational Scenario: C/A-code Receiver and Multiple UWB Devices - Indoor Operation

## **SECTION 4.0**

### **SUMMARY/CONCLUSIONS**

#### **4.1 SUMMARY OF MEASUREMENT FINDINGS**

In the measurement component of this assessment, 32 UWB signal permutations were identified for examination with respect to the interference potential to GPS receivers. For each of four pulse repetition frequencies (PRFs); 100 kHz, 1 MHz, 5 MHz, and 20 MHz, eight distinct UWB waveforms were generated by combining four modulation types (constant PRF, On-Off Keying (OOK), 2% relative dither, and 50% absolute dither) and two states of gating (100% and 20%). Each of these UWB parameters are described in the paragraphs below.

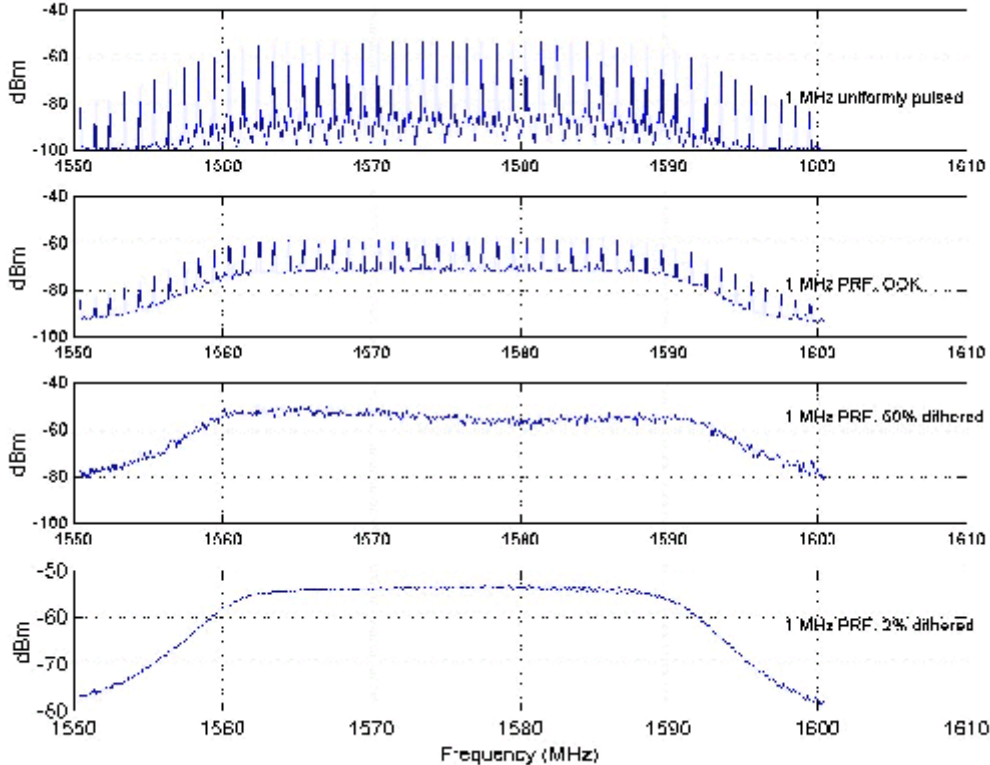
The PRF defines the number of pulses transmitted per unit time (seconds). The PRF governs both the magnitude and spacing of the spectral lines. For example, a 5 MHz PRF signal produces spectral lines that are spaced every 5 MHz in the frequency domain. As the PRF is increased, the spectral lines become spaced further apart, but the energy contained in each spectral line is increased. Within the context of this report, “constant PRF” refers to an unmodulated UWB signal.

Gating refers to the process of distributing pulses in bursts by employing a programmed set of periods where the UWB transmitter is turned on or off for a period of pulses. For the measurements performed in this study, the gated UWB signal utilized a scheme where a burst of data lasting 4 ms was followed by a 16 ms period when no pulses were transmitted. This is referred to as 20% gating, because the UWB pulses are transmitted 20% of the time. The signal permutations depicted within this report as 100% gating, define a signal where pulses are transmitted 100% of the time.

OOK refers to the process of selectively turning off or eliminating individual pulses to represent data bits. With OOK modulation, the energy in the spectrum is equally divided between the spectral line components and the noise continuum component.

Dithering refers to the random or pseudo-random spacing of the pulses. Two forms of dithered UWB signals were considered in this effort. These are an absolute referenced dither, where the pulse period is varied in relation to the absolute clock, and a relative referenced dither, where the pulse spacing is varied relative to the previous pulse. The PRF of a relative dithered pulse train is equal to the reciprocal of the mean pulse period. Dithering of the pulses in the time domain spreads the spectral line content of a UWB signal in the frequency domain making the signal appear more noise-like.

For illustration, Figure 4-1 shows the spectral content for a 1 MHz PRF UWB signal as measured in a 24 MHz bandpass filter when: unmodulated, OOK modulated, 50% absolute reference dithered, and 2% relative referenced dithered.



**Figure 4-1. Illustration of Modulation Effects on a UWB Signal as Measured in a 24 MHz Bandpass Filter**

The results of this measurement effort were found to be UWB signal-dependent and are strongly related to the PRF examined. Thus, in this section, the summary of the measurement results, and the conclusions drawn from them, will be grouped by UWB signal PRF for each of the GPS receivers measured.

#### **4.1.1 C/A-code GPS Receiver**

Previous work in quantifying interference to GPS receivers has been performed in RTCA and ITU-R technical working groups comprised of GPS experts. Much of this work has focused on the effect of different interference types to C/A-code GPS receivers, since these represent the most predominant GPS architecture currently present in the civilian marketplace. This work has determined that GPS C/A-code receivers are most susceptible to CW-like interference. This is due to the potential for interfering spectral lines to become aligned with the 1 kHz spaced spectral lines of the GPS C/A-code, produced as a result of the relatively short, periodic nature of the Gold codes used to generate the pseudorandom sequences necessary for code division multiple access (CDMA) operation. RTCA and ITU-R have documented an interference protection level of -150.5 dBW, at the input of the GPS receiver, as necessary to protect

GPS receivers from this type of interfering signal.<sup>71</sup> GPS C/A-code receivers are also susceptible to broadband noise-like interference where the documented protection level, at the input of the GPS C/A-code receiver, is -140.5 dBW/MHz.<sup>72</sup>

RTCA has also determined that GPS C/A-code receivers are less sensitive to low duty cycle pulse-like interfering signals. The interference protection level documented for this type of interference is +20 dBm (peak pulse power), at the input to the receiver, for duty cycles less than 10%.<sup>73</sup>

The results of the measurements performed as a part of this assessment agree with the RTCA and the ITU-R protection limits. In the analysis of the measurement results, NTIA found that the interference effects on the GPS C/A-code receiver from each of the UWB signals considered in this assessment could be classified as one of the three conventional interference types; CW-like, noise-like, or pulse-like interference. The APD measurements performed for each of the UWB signal permutations provide some insight into the classification of the waveforms into these three categories.<sup>74</sup> Once the UWB signal was determined to be characteristic of CW-like, noise-like, or low duty cycle pulse-like, a comparison of the measured interference thresholds with the documented interference protection limits are consistent after adjustments are made to account for the difference in GPS signal level assumed at the input to the receiver. The development of the interference protection limits within the RTCA and ITU-R assumed an aviation scenario in which GPS satellites located at or near the horizon are typically unobstructed with respect to a GPS receiver antenna at altitude, and thus can be used in the navigation solution. Within this aviation scenario, the minimum guaranteed GPS signal is assumed to be received through a sidelobe of the GPS antenna, with an antenna gain of -4.5 dBic. In establishing the GPS signal power to use in this measurement effort, a terrestrial scenario was assumed in which those satellites on the horizon are typically obstructed with respect to a GPS antenna. Thus, the minimum guaranteed GPS signal was assumed to be received by the GPS antenna with a gain of 0 dBic. Any applicable scenario-dependent adjustment to the GPS antenna gain is then accounted for in the analysis. For this reason, the measured interference thresholds presented in the following tables must be adjusted by -4.5 dB to account for differences in the antenna gain in order to compare with the interference protection limits defined within the literature.

Tables 4-1 through 4-4 list the measured interference thresholds for the GPS C/A-code receiver. Depending on the UWB signal permutation under consideration, adjustments had to be made to: 1) convert from a 20 MHz bandwidth to a 1 MHz bandwidth, 2) convert from dBm to dBW, 3) determine

---

<sup>71</sup> RTCA 229B at C-2; ITU-R M.1477 at Table 1.

<sup>72</sup> Id.

<sup>73</sup> RTCA 229B at C-5.

<sup>74</sup> ITS Report at 55.

the power contained in a spectral line for CW-like signals, 4) account for the division of power between the spectral lines and the noise continuum for OOK modulated signals, and 5) to adjust for gate on-time relative to total time for the gated signals. These adjustments are discussed in detail in section 2.2.2.1 and in Table 3-11 of this document. The adjusted interference threshold level is presented in the last column of these tables. It is this interference threshold level, that when adjusted by -4.5 dB (see discussion above), compares favorably with the published interference protection limits (see Table 2-7).

The results from the aggregate measurements indicate the following with respect to the UWB waveforms examined: 1) for those waveforms associated with a PRF greater than 100 kHz, that were classified as pulse-like, a transition to a noise-like effect occurs when three or more UWB transmitters are assumed to be operating with equivalent power levels at the input to the GPS receiver, 2) when UWB waveforms characteristic of noise-like interference are considered in the aggregate, the effective signal at the output of the GPS receiver IF is determined by adding the average power of each interference signal, and 3) when those UWB signal permutations classified as CW-like are aggregated, the interference mechanism remains that of the individual CW-like signal, i.e., a spectral line alignment between a UWB spectral line and a dominant GPS code line, where the amplitude in the UWB spectral line exceeds that of the GPS code line. As such, the CW-like UWB signals do not add; however, an increase in the number of spectral lines present in the GPS passband, due to an aggregation of UWB devices, is expected to increase the probability of the occurrence of spectral line coincidence. This result is based on the results of the aggregate measurements performed as a part of this study, which was limited by the number of available UWB signal sources.

In Table 4-1, the measured interference thresholds are shown for all eight UWB signal permutations operating at a PRF of 100 kHz. For these waveforms, with the exception of the unmodulated case, the UWB signal generator could not produce enough power to cause the receiver to break-lock with the satellite of interest. This is likely due to the lesser susceptibility of GPS C/A-code receivers to low duty cycle pulsed interference. In these cases, the highest attainable UWB generator power level was recorded and used as the interference threshold in the subsequent analyses. The results shown in the table are those obtained from the single-entry (one UWB transmitter-to-GPS receiver) interaction measurements. The 100 kHz UWB signal permutations were not considered in the aggregate measurements for two reasons. First, a computer simulation was performed to provide an insight into the likely number of 100 kHz PRF UWB signals that would have to be present to produce an equivalent received power at the GPS receiver for an aggregate effect to be observed. The results of the simulation indicated that it would take considerably more than the six UWB generators available to this effort to produce an aggregate effect to the GPS receiver under test for a 100 kHz PRF UWB signal. Second, it is likely that the most probable UWB applications for a 100 kHz PRF signal are for radar or imaging such as ground penetration and through the wall imaging. These types of applications are not expected to result in an extremely large proliferation of UWB devices in the same geographic area, and thus, an aggregate of a large number of these types of devices was deemed unlikely.

**TABLE 4-1. UWB Interference Thresholds for C/A-Code Receiver (100 kHz PRF)**

UWB Signal Permutation	Signal Description	Category of Interfering Signal	$I_{meas}$ (dBm/20 MHz)	$I_T$ (see Table 3-11)
No Mod; 100% gate	Constant PRF; 100% on-time	pulse-like	-70.0	-112.6 dBW/MHz
No Mod; 20% gate	Constant PRF; 20% on-time	pulse-like	-57.0 <sup>a</sup>	-106.5 dBW/MHz <sup>b</sup>
OOK; 100% gate	On Off Keying Modulated; 100% on-time	pulse-like	-60.0 <sup>a</sup>	-102.6 dBW/MHz <sup>b</sup>
OOK; 20% gate	On-Off Keying Modulated; 20% on-time	pulse-like	-59.5 <sup>a</sup>	-109.4 dBW/MHz <sup>b</sup>
50% abs; 100% gate	50% Absolute Dithered; 100% on-time	pulse-like	-57.0 <sup>a</sup>	-100.0 dBW/MHz <sup>b</sup>
50% abs; 20% gate	50% Absolute Dithered; 20% on-time	pulse-like	-56.5 <sup>a</sup>	-107.0 dBW/MHz <sup>b</sup>
2% rel; 100% gate	2% Relative Dithered; 100% on-time	pulse-like	-57.0 <sup>a</sup>	-100.0 dBW/MHz <sup>b</sup>
2% rel; 20% gate	2% Relative Dithered; 20% on-time	pulse-like	-57.0 <sup>a</sup>	-107.0 dBW/MHz <sup>b</sup>
<b>Notes:</b>				
<sup>a</sup> Interference threshold not reached at maximum available UWB generator power.				
<sup>b</sup> $I_T$ computed from maximum UWB generator power reading.				

Table 4-2 lists the measured interference thresholds for the eight UWB signal permutations utilizing a PRF of 1 MHz. At the 1 MHz PRF, CW-like degradation effects are first observed to the GPS receiver at levels commensurate with the published interference protection limits. This occurs for the case of the unmodulated UWB signal shown in the table. For the remaining seven UWB signal permutations, the interference effects are classified as either pulse-like or noise-like, when considered in the single-entry measurements. However, based on the results of the aggregate measurements, for those 1 MHz PRF UWB waveforms that were characterized as having a pulse-like interference effect to the GPS C/A-code receiver, a transition to noise-like interference effects occurs when as few as three signals are considered.

**TABLE 4-2. UWB Interference Thresholds for C/A-Code Receiver (1 MHz PRF)**

UWB Signal Permutation	Signal Description	Category of Interfering Signal	$I_{meas}$ (dBm/20 MHz)	$I_T$ (see Table 3-11)
No Mod; 100% gate	Constant PRF; 100% on-time	CW-like	-100.5	-143.7 dBW
No Mod; 20% gate	Constant PRF; 20% on-time	pulse-like <sup>a</sup>	-47.5 <sup>b</sup>	-97.6 dBW/MHz <sup>c</sup>
		noise-like <sup>d</sup>	-91.5	-134.5 dBW/MHz
OOK; 100% gate	On Off Keying Modulated; 100% on-time	pulse-like <sup>a</sup>	-78.0	-121.2 dBW/MHz
		noise like <sup>d</sup>	-91.5	-134.5 dBW/MHz
OOK; 20% gate	On-Off Keying Modulated; 20% on-time	pulse-like <sup>a</sup>	-51.0 <sup>b</sup>	-101.1 dBW/MHz <sup>c</sup>
		noise-like <sup>d</sup>	-91.5	-134.5 dBW/MHz
50% abs; 100% gate	50% Absolute Dithered; 100% on-time	pulse-like <sup>a</sup>	-70.0	-113.0 dBW/MHz
		noise-like <sup>d</sup>	-91.5	-134.5 dBW/MHz
50% abs; 20% gate	50% Absolute Dithering; 20% on-time	pulse-like <sup>a</sup>	-47.5 <sup>b</sup>	-97.5 dBW/MHz <sup>c</sup>
		noise-like <sup>d</sup>	-91.5	-134.5 dBW/MHz
2% rel; 100% gate	2% Relative Dithering; 100% on-time	pulse-like <sup>a</sup>	-88.0	-131.0 dBW/MHz
		noise-like <sup>d</sup>	-91.5	-134.5 dBW/MHz
2% rel; 20% gate	2% Relative Dithering; 20% on-time	pulse-like <sup>a</sup>	-47.0	-97.0 dBW/MHz
		noise-like <sup>d</sup>	-91.5	-134.5 dBW/MHz
<b>Notes:</b>				
<sup>a</sup> Single-entry (one UWB transmitter-to-GPS receiver) interaction.				
<sup>b</sup> Interference threshold not reached at maximum available UWB generator power.				
<sup>c</sup> $I_T$ computed from maximum available UWB generator power reading.				
<sup>d</sup> Aggregate (multiple (\$3) UWB transmitters-to-GPS receiver) interaction, based on broad-band noise measurement.				

Table 4-3 lists the measured interference thresholds for the eight UWB signal permutations considered that utilized a PRF of 5 MHz. As can be seen from this table, the CW-like impact to the GPS C/A-code receiver becomes more prevalent at the higher PRF. At this PRF, four of these eight UWB waveforms were classified as CW-like with respect to their impact to the GPS C/A-code receiver under test. The results presented in this table also indicate that the dithering techniques considered in this effort can be effective in improving the interference impact to the GPS C/A-code receiver. This is likely due to the spreading of the spectral lines from dithering the signal in the time domain, making it appear more noise-like in the frequency domain. For the two UWB waveforms examined that employed a

combination of dithering and gating, the impact observed to the GPS C/A-code receiver in the single-entry case was characteristic of low-duty cycle pulsed interference. However, based on the results of the aggregate measurements, when a multiple of these UWB signals are considered with PRFs greater than 100 kHz, the duty cycle of the effective aggregate signal at the output of the GPS C/A-code receiver IF begins to transition to a noise-like effect, for which the C/A-code receiver shows a greater susceptibility.

**TABLE 4-3. UWB Interference Thresholds for C/A-Code Receiver (5 MHz PRF)**

UWB Signal Permutation	Signal Description	Category of Interfering Signal	I <sub>meas</sub> (dBm/20 MHz)	I <sub>r</sub> (see Table 3-11)
No Mod; 100% gate	Constant PRF; 100% on-time	CW-like	-108.5	-145.5 dBW
No Mod; 20% gate	Constant PRF; 20% on-time	CW-like	-94.5	-145.2 dBW
OOK; 100% gate	On-Off Keying Modulated; 100% on-time	CW-like	-104.5	-144.5 dBW
OOK; 20% gate	On-Off Keying Modulated; 20% on-time	CW-like	-90.5	-144.2 dBW
50% abs; 100% gate	50% Absolute Dithered; 100% on-time	noise-like	-94.0	-137.0 dBW/MHz
50% abs; 20% gate	50% Absolute Dithered; 20% on-time	pulse-like <sup>a</sup>	-55.0 <sup>b</sup>	-105.0 dBW/MHz <sup>c</sup>
		noise-like <sup>d</sup>	-91.5	-134.5 dBW/MHz
2% rel; 100% gate	2% Relative Dithered; 100% on-time	noise-like	-93.5	-136.5 dBW/MHz
2% rel; 20% gate	2% Relative Dithered; 20% on-time	pulse-like <sup>a</sup>	-39.0 <sup>b</sup>	-89.0 dBW/MHz <sup>c</sup>
		noise-like <sup>d</sup>	-91.5	-134.5 dBW/MHz
<b>Notes:</b>				
<sup>a</sup> Single-entry (one UWB transmitter-to-GPS receiver) interaction.				
<sup>b</sup> Interference threshold not reached at maximum available UWB generator power.				
<sup>c</sup> I <sub>r</sub> computed from maximum available UWB generator power reading.				
<sup>d</sup> Aggregate (multiple (3) UWB transmitters-to-GPS receiver) interaction, based on broad-band noise measurement.				

Table 4-4 lists the measured interference thresholds for the eight UWB waveforms using a PRF of 20 MHz. The results are similar to those of the 5 MHz PRF UWB signals. Four of the eight UWB waveforms examined cause a CW-like interference effect to the GPS C/A-code receiver. Dithering of the signal using the techniques considered in this assessment appears to continue to be effective in spreading the spectral lines and thus causing an effect to the GPS C/A-code receiver more characteristic



of pulse-like interference when employed in combination with gating (in the single-entry interaction), or noise-like when gating is not used. For those UWB waveforms that were classified as pulse-like, the aggregate measurement results suggest that when three or more of these UWB signals are considered, the effective pulse duty cycle increases to a point where the interference effect to the GPS receiver transitions to that of noise-like interference.

**TABLE 4-4. UWB Interference Thresholds for C/A-Code Receiver (20 MHz PRF)**

UWB Signal Permutation	Signal Description	Category of Interfering Signal	$I_{meas}$ (dBm/20 MHz)	$I_T$ (see Table 3-11)
No Mod; 100% gate	Constant PRF; 100% on-time	CW-like	-115.0	-145.0 dBW
No Mod; 20% gate	Constant PRF; 20% on-time	CW-like	-102.0	-145.8 dBW
OOK; 100% gate	On Off Keying Modulated; 100% on-time	CW-like	-111.5	-144.5 dBW
OOK; 20% gate	On-Off Keying Modulated; 20% on-time	CW-like	-99.5	-146.3 dBW
50% abs; 100% gate	50% Absolute Dithered; 100% on-time	noise-like	-95.0	-138.0 dBW/MHz
50% abs; 20% gate	50% Absolute Dithered; 20% on-time	pulse-like <sup>a</sup>	-85.0	-135.0 dBW/MHz <sup>c</sup>
		noise-like <sup>d</sup>	-91.5	-134.5 dBW/MHz
2% rel; 100% gate	2% Relative Dithered; 100% on-time	noise-like	-93.0	-136.0 dBW/MHz
2% rel; 20% gate	2% Relative Dithered; 20% on-time	pulse-like <sup>a</sup>	-83.0	-133 dBW/MHz <sup>c</sup>
		noise-like <sup>d</sup>	-91.5	-134.5 dBW/MHz
<b>Notes:</b> <sup>a</sup> Single-entry (one UWB transmitter-to-GPS receiver) interaction. <sup>b</sup> Interference threshold not reached at maximum available UWB generator power. <sup>c</sup> $I_T$ computed from maximum available UWB generator power reading. <sup>d</sup> Aggregate (multiple (\$3) UWB transmitters-to-GPS receiver) interaction, based on broad-band noise measurement.				

#### 4.1.2 Semi-Codeless GPS Receiver

In this section, the results from the measurement of the susceptibility of a GPS semi-codeless receiver to the set of UWB signal permutations are presented and discussed.

A semi-codeless GPS receiver processes the transmitted GPS P-code signals at the L1 (1575.42 MHz) and L2 (1227.60 MHz) frequencies to provide an accurate measure of the ionospheric delay of the signal received from the satellite. The GPS P-code signal employs a longer pseudorandom code as compared with the Gold code used with the GPS C/A signal. As a result of the use of this longer code, the P-code signal has essentially no spectral line content within its power spectral envelope. Thus, it was anticipated that the CW-like interference mechanism to which the GPS C/A-code tracking receiver is most susceptible, would not be an interference mechanism of concern to the semi-codeless GPS receiver. This premise was borne out in the measurement results for this receiver when an unmodulated 20 MHz PRF and an OOK modulated UWB signal (known from the APDs to be CW-like) were introduced. Therefore, having verified through measurement that spectral line content in the UWB signal is not of particular concern to this GPS receiver architecture, and in an effort to expedite the measurement effort, NTIA reduced the number of signal permutations examined, by eliminating those UWB signal permutations known to produce CW-like signals for the 1 MHz and 5 MHz PRFs. The full complement of UWB signal permutations was retained for the 100 kHz and the 20 MHz PRFs.

Tables 4-5 through 4-8 list the measured semi-codeless receiver interference thresholds for each of the eight UWB waveforms produced, grouped according to PRF.

The results presented in Table 4-5 indicate that the semi-codeless receiver shows a tolerance to low duty cycle pulsed interference, similar to that of the C/A-code tracking receiver. In four of the eight 100 kHz PRF UWB waveforms, the interference threshold was not reached at the maximum output power available from the UWB generator. For the remaining four 100 kHz PRF UWB waveforms, the interference threshold was realized, but at relatively high UWB power levels.

The results presented in Tables 4-6 through 4-8 list the measured interference thresholds at the input to the semi-codeless GPS receiver when subjected to the UWB signal permutations at PRFs of 1, 5, and 20 MHz. These results indicate that the UWB waveforms examined with a PRF greater than 100 kHz, impact the GPS semi-codeless receiver similar to broadband noise-like interference. The results presented in the table also support the observation that this receiver architecture is more sensitive to broadband noise-like interference than the C/A-code tracking GPS receiver. This increased sensitivity to noise-like interference was attributed to the following two factors. The GPS signal level provided to this receiver was 3 dB lower than what was provided in the measurement of the C/A-code receiver, in order to represent the lower signal power of the L1 and L2 P-code signals. Also, semi-codeless processing is inherently noisy and thus is likely more sensitive to an increase in additive noise. It should also be noted that these receiver architectures are not completely independent from C/A-code operation. Not only do they rely on the C/A-code for initial acquisition, they also typically default to C/A-code operations if the P-code signals become unavailable.

**TABLE 4-5. UWB Interference Thresholds for Semi-Codeless Receiver (100 kHz PRF)**

UWB Signal Permutation	Signal Description	Category of Interfering Signal	$I_{meas}$ (dBm/20 MHz)	$I_r$ (dBW/MHz)
No Mod; 100% gate	Constant PRF; 100% on-time	pulse-like	-75.0	-118.0
No Mod; 20% gate	Constant PRF; 20% on-time	pulse-like	-66.0 <sup>a</sup>	-116.5
OOK; 100% gate	On Off Keying Modulated; 100% on-time	pulse-like	-68.0 <sup>a</sup>	-112.0
OOK; 20% gate	On-Off Keying Modulated; 20% on-time	pulse-like	-68.0 <sup>a</sup>	-118.5
50% abs; 100% gate	50% Absolute Dithered; 100% on-time	pulse-like	-78.0	-121.0
50% abs; 20% gate	50% Absolute Dithered; 20% on-time	pulse-like	-66.0 <sup>a</sup>	-116.0
2% rel; 100% gate	2% Relative Dithered; 100% on-time	pulse-like	-76.0	-119.0
2% rel; 20% gate	2% Relative Dithered; 20% on-time	noise-like	-88.0	-138.0
<b>Notes:</b> <sup>a</sup> Interference threshold not reached at maximum available UWB generator power.				

**TABLE 4-6. UWB Interference Thresholds for Semi-Codeless Receiver (1 MHz PRF)**

UWB Signal Permutation	Signal Description	Category of Interfering Signal	$I_{meas}$ (dBm/20 MHz)	$I_r$ (dBW/MHz)
50% abs; 100% gate	50% Absolute Dithered; 100% on-time	noise-like	-108.0	-151.0
50% abs; 20% gate	50% Absolute Dithering; 20% on-time	noise-like	-82.0	-132.0
2% rel; 100% gate	2% Relative Dithering; 100% on-time	noise-like	-106.0	-149.0
2% rel; 20% gate	2% Relative Dithering; 20% on-time	noise-like	-84.0	-134.0

**TABLE 4-7. UWB Interference Thresholds for Semi-Codeless Receiver (5 MHz PRF)**

UWB Signal Permutation	Signal Description	Category of Interfering Signal	$I_{meas}$ (dBm/20 MHz)	$I_r$ (dBW/MHz)
50% abs; 100% gate	50% Absolute Dithered; 100% on-time	noise-like	-108.0	-151.0
50% abs; 20% gate	50% Absolute Dithered; 20% on-time	noise-like	-101.0	-151.0
2% rel; 100% gate	2% Relative Dithered; 100% on-time	noise-like	-106.0	-149.0
2% rel; 20% gate	2% Relative Dithered; 20% on-time	noise-like	-92.5	-142.5

**TABLE 4-8. UWB Interference Thresholds for Semi-Codeless Receiver (20 MHz PRF)**

UWB Signal Permutation	Signal Description	Category of Interfering Signal	$I_{meas}$ (dBm/20 MHz)	$I_r$ (dBW/MHz)
No Mod; 100% gate	Constant PRF; 100% on-time	noise-like	-102.0	-145.0
No Mod; 20% gate	Constant PRF; 20% on-time	noise-like	-98.0	-148.0
OOK; 100% gate	On Off Keying Modulated; 100% on-time	noise-like	-94.0	-137.0
OOK; 20% gate	On-Off Keying Modulated; 20% on-time	noise-like	-96.0	-146.0
50% abs; 100% gate	50% Absolute Dithered; 100% on-time	noise-like	-106.5	-149.5
50% abs; 20% gate	50% Absolute Dithered; Gated (20% on-time)	noise-like	-98.0	-148.0
2% rel; 100% gate	2% Relative Dithered; 100% on-time	noise-like	-106.5	-149.5
2% rel; 20% gate	2% Relative Dithered; 20% on-time	noise-like	-93.5	-143.5

### 4.1.3 Measurement Conclusions

The measurements indicate that both the C/A-code tracking GPS receiver and the semi-codeless GPS receiver demonstrate a tolerance to all of the UWB signal permutations examined with a PRF of

100 kHz. For the scenarios considered in this assessment, aggregate effects were deemed not to be a concern with respect to those UWB waveforms with a PRF of 100 kHz. When the PRF was increased to 1 MHz, the C/A-code receiver began to show CW-like interference susceptibility to the unmodulated UWB signal permutations at low power levels. When the PRF was increased to 5 MHz and then to 20 MHz, CW-like interference effects to the C/A-code receiver became more prevalent.

These measurements also show that dithering of the UWB pulses in the time domain, using the techniques considered in this assessment, can be effective in spreading the spectral lines in the frequency domain, making the effective signal appear more noise-like. The GPS C/A-code receiver showed approximately 10 dB less sensitivity to these noise-like UWB signals. For PRFs above 100 kHz, a few of the UWB waveforms caused an effect similar to low duty cycle pulsed interference, to which the GPS C/A-code receiver is relatively tolerant. However, the multiple-entry (aggregate) measurements indicate that this advantage is lost when a multiple of as few as three of these UWB signals are considered in aggregation. The aggregate measurements also tend to verify that when multiple noise-like UWB signals are considered, the effective aggregate signal level in the GPS receiver IF is determined by adding the average power of each of the interfering signals.

The semi-codeless receiver measured in this assessment showed a susceptibility similar to what would be expected from broadband noise-like interference for all of the UWB signal permutations employing PRFs of greater than 100 kHz. The semi-codeless GPS receiver was also observed to be more susceptible than the C/A-code receiver to noise-like interference.

The results of the radiated measurements verified that only the GPS antenna gain in the direction of the UWB transmitting device need be considered in the calculating the EIRP from the measured interference thresholds. These results demonstrate that the UWB signals provided to the GPS receivers via a conducted path were consistent with what the GPS receiver would see when the signals were received by a GPS antenna and preamplifier via a radiated path as will be the case in actual operational conditions.

The measurements performed for this assessment assumed GPS operation in the tracking mode of operation (i.e., the GPS receiver was allowed to acquire the satellites necessary to obtain a navigation solution before UWB interference was introduced). The initial (cold-start) acquisition mode of GPS receiver operation is known to be more sensitive to interference than the tracking mode. However, measurements of GPS receiver susceptibility to interference when operating in the cold-start acquisition mode are difficult to perform. Within the RTCA and ITU-R working groups, mentioned previously in this report, the initial acquisition mode of operation is accounted for by reducing the tracking mode interference protection levels by 6 dB.

Additionally, for some of the UWB signal permutations considered in this assessment, a statistically meaningful measurement of the preferred reacquisition interference threshold could not be made. The reacquisition threshold is the UWB power level that results in an abrupt increase in reacquisition time.

For these cases, it was necessary to utilize the UWB power level resulting in break-lock as a threshold. A break-lock condition occurs when a GPS receiver can no longer adequately determine the pseudorange for a given satellite because of interference. This was particularly true for those UWB signals that caused a CW-like interference effect in the C/A-code GPS receiver. This does not constitute an endorsement of the use of break-lock as the preferred interference threshold on which to establish final rules for UWB operation.

## **4.2 SUMMARY OF ANALYSIS FINDINGS**

There are literally hundreds of applications of GPS, with additional applications being defined on a seemingly daily basis. To attempt to define a unique operational scenario for each of these applications would be a massive, if not impossible undertaking. Therefore, within the context of this assessment, an effort was made to define a set of operational scenarios, in conjunction with the GPS user and UWB communities, that could be used to bound the possible GPS applications.

The two main parameters needed to perform the analyses, which are defined by the operational scenarios, are the likely separation distance between a GPS receiver and UWB transmitter, and the likely orientation of the antennas with respect to one another. The likely separation distance is used to assess the propagation path loss, to formulate an assumption as to the likelihood of multiple UWB devices in view of the GPS receiver, and to determine the interference allotment for UWB devices within the constraints defined by the application. The likely antenna orientation is used to estimate the antenna gain realized by the GPS antenna in the direction of the UWB devices.

In the public meetings that were held, a set of operational scenarios were defined that NTIA accepts as bounding the parameters of interest. For example, the terrestrial scenarios involving the public safety use of GPS, define a minimum separation distance of 2 meters. The en-route aviation operational scenario defines a minimum separation distance of 1000 feet (approximately 300 meters). These two cases bound the distance separation of the remaining operational scenarios. Furthermore, it appears reasonable that these two scenarios will also bound operational scenarios not specifically considered within this effort, with respect to distance separation. Additionally, it is reasonable to assume that there will be a limited number of UWB devices operating at a distance of 2 meters from a GPS receiver, as defined by the terrestrial operational scenario discussed in Section 3. However, when the en-route aviation scenario is considered, a larger number of UWB devices can be in view from an aircraft at an altitude of 1000 feet. Therefore, it is believed that the operational scenarios considered also bound the GPS application space with respect to the potential aggregation of UWB devices.

In this analysis, NTIA determined the maximum allowable EIRP for the different UWB signal permutations, using the operational scenarios proposed in the public meetings. The results of the analysis are summarized in Tables 4-9 through 4-12. Each table corresponds to a UWB PRF examined in the analysis. The tables provide a description of the: operational scenario; UWB signal characteristics; GPS receiver architecture; interfering signal classification; interference threshold; and the computed values of

maximum allowable EIRP. The values of maximum allowable EIRP shown in the Tables 4-9 through 4-12 are for a single UWB device, and represent the highest EIRP at which UWB devices can operate and still provide protection to the GPS receiver architecture under consideration for the conditions specified in the operational scenarios.

Tables 4-9 through 4-12 also include a comparison of the computed values of maximum allowable EIRP with the current Part 15 level of -71.3 dBW/MHz. When the interference effects are classified as pulse-like or noise-like, the values of maximum allowable EIRP can be directly compared to the current Part 15 level. When the interference effect is classified as being CW-like, the maximum allowable EIRP can be compared to the Part 15 level, if it is assumed that there is only a single spectral line in the measurement bandwidth. If the difference between the current Part 15 level and the computed maximum allowable EIRP is negative, no additional attenuation below the current Part 15 level is necessary to protect the GPS receiver architecture under consideration. If the difference is positive, this value specifies the additional attenuation below the current Part 15 level that is necessary to protect the GPS receiver architecture under consideration.

Table 4-9 summarizes the analysis results for UWB devices that operate with a PRF of 100 kHz. For the C/A-code receiver architecture, when the operational scenario includes either a single UWB device or a small number of UWB devices operating with a PRF of 100 kHz, the interference effect was categorized as being pulse-like. The computed values of maximum allowable EIRP range from -73.2 to -40.5 dBW/MHz depending upon the operational scenario under consideration. In the aviation (en-route navigation) operational scenarios, it is assumed that there is a large number of UWB devices present such that, independent of the individual UWB signal parameters, the interference effect can be classified as noise-like (i.e., central limit theorem). The computed values of maximum allowable EIRP are -76.6 dBW/MHz when all of the UWB devices were operating inside of a building and -85.6 dBW/MHz when all of the UWB devices were operating outside of a building.

In the surveying operational scenarios the semi-codeless receiver architecture was considered. As a result of the correlation process that uses the longer P-code signals, the interference effect was classified as noise-like. As shown in Table 4-9, the values of computed maximum allowable EIRP are -81.1 dBW/MHz and -81.2 dBW/MHz for single and multiple (as defined by the operational scenario) UWB device interactions respectively.

Table 4-10 summarizes the analysis results for UWB devices that operate with a PRF of 1 MHz. For the C/A-code receiver architecture, when the operational scenario includes either a single UWB device or a small number of UWB devices operating with a PRF of 1 MHz, the interference effect was classified as CW-like, pulse-like, or noise-like. This classification depends on the modulation and gating percentage employed. When the operational scenario considered a single UWB device employing 100% gating and no modulation, the interference effect was classified as CW-like. For all other signal permutations, the single entry UWB device interaction interference effect was classified as pulse-like. For the single UWB device operational scenario, the interference effect was classified as pulse-like, the

maximum allowable EIRP is -91.6 dBW/MHz. When the interference effect was classified as CW-like, the computed values of maximum allowable EIRP range from -104.3 to -71.6 dBW, depending on the operational scenario under consideration. In the operational scenarios where multiple UWB device interactions were considered, the interference effect for 1 MHz, 100% gating, was still CW-like. However, for all other 1 MHz UWB signal permutations, the interference effect was classified as noise-like. When the multiple UWB device interaction interference effect was classified as noise-like, the computed values of maximum allowable EIRP range from -90.2 to -68.4 dBW/MHz, depending upon the operational scenario under consideration. In the aviation (en-route navigation) operational scenarios, there were a large number of UWB devices assumed to be present, therefore the interfering signal was classified as noise-like. The computed values of maximum allowable EIRP are -76.6 dBW/MHz when all of the UWB devices were operating inside of a building and -85.6 dBW/MHz when all of the UWB devices were operating outside of a building.

In the surveying operational scenarios, where the semi-codeless receiver architecture was analyzed, the interference effect was classified as noise-like. As shown in Table 4-10, the values of computed maximum allowable EIRP were -94.1 dBW/MHz and -94.2 dBW/MHz for single and multiple (as defined by the operational scenario) UWB device interactions respectively.

Table 4-11 summarizes the analysis results for UWB devices that operate with a PRF of 5 MHz. In the terrestrial operational scenario where a single UWB device is operating with a PRF of 5 MHz, the interference effect was classified as CW-like, pulse-like, or noise-like. This classification depends on the type of modulation and gating percentage that was employed. The computed values of maximum allowable EIRP for the different interfering signal classifications were: -106.1 dBW (CW-like), -65.6 dBW/MHz (pulse-like), and -97.6 dBW/MHz (noise-like). In the operational scenarios where a small number of UWB devices with a PRF of 5 MHz were operating, the interference effect was classified as either CW-like or noise-like. This classification depends on the type of modulation and gating percentage that was employed. When the interference effect was classified as being CW-like, the values of maximum allowable EIRP range from -95.2 to -73.4 dBW, depending on the operational scenario under consideration. When the interference effect was classified as noise-like, the values of maximum allowable EIRP range from -92.7 dBW/MHz to -70.9 dBW/MHz, depending on the operational scenario under consideration. In the aviation (en-route navigation) operational scenarios, there were a large number of UWB devices assumed to be present, therefore the interfering signal was classified as noise-like. The computed values of maximum allowable EIRP are -76.6 dBW/MHz when all of the UWB devices were operating inside of a building and -85.6 dBW/MHz when all of the UWB devices were operating outside of a building.

In the surveying operational scenarios, where the semi-codeless receiver architecture was considered, the interference effect was classified as being noise-like. As shown in Table 4-11, the values of computed maximum allowable EIRP were -94.1 dBW/MHz and -94.2 dBW/MHz for single and multiple (as defined by the operational scenario) UWB device interactions respectively.



Table 4-12 summarizes the analysis results for UWB devices that operate with a PRF of 20 MHz. In the terrestrial operational scenario where a single UWB device is operating with a PRF of 20 MHz, the interference effect was classified as CW-like, pulse-like, or noise-like. This classification depends on the type of modulation and gating percentage that was employed. The computed values of maximum allowable EIRP for the different interfering signal classifications were: -106.9 dBW (CW-like), -95.6 dBW/MHz (pulse-like), and -98.6 dBW/MHz (noise-like). In the operational scenarios where a small number of UWB devices with a PRF of 20 MHz are operating, the interference effect was classified as being either CW-like or noise-like. This classification depends on the type of modulation and gating percentage that was employed. When the interference effect was classified as CW-like, the values of maximum allowable EIRP range from -96 dBW to -74.2 dBW, depending on the operational scenario under consideration. When the interference effect was classified as being noise-like, the values of maximum allowable EIRP range from -93.7 to -71.9 dBW/MHz, depending on the operational scenario under consideration. In the aviation (en-route navigation) operational scenarios, there were a large number of UWB devices assumed to be present, and the interference effect was classified as being noise-like. The computed values of maximum allowable EIRP are -76.6 dBW/MHz when all of the UWB devices were operating inside of a building and -85.6 dBW/MHz when all of the UWB devices were operating outside of a building.

In the surveying operational scenarios, where the semi-codeless receiver architecture was considered, the interference effect was classified as being noise-like. As shown in Table 4-12, the values of computed maximum allowable EIRP were -92.6 dBW/MHz and -92.7 dBW/MHz for single and multiple (as defined by the operational scenario) UWB device interactions respectively.

**Table 4-9. Summary of Analysis Results (PRF = 100 kHz)**

Operational Scenario Description					UWB Signal Characteristics			GPS Receiver Architecture	Classification of Interfering Signal	Maximum Interference Threshold (dBW/MHz)	Maximum Allowable EIRP (dBW/MHz)	Comparison with the Current Part 15 Level (dB)
Application	UWB Single	UWB Multiple	UWB Indoor	UWB Outdoor	PRF (MHz)	Gating %	Mod.					
Terrestrial	X			X	0.1	100	None	C/A-code	Pulse-Like	-112.6	-73.2	1.9
Terrestrial		X	X		0.1	100	None	C/A-code	Pulse-Like	-112.6	-57.6	-13.7
Terrestrial		X		X	0.1	100	None	C/A-code	Pulse-Like	-112.6	-62.3	-9
Maritime		X	X		0.1	100	None	C/A-code	Pulse-Like	-112.6	-41.7	-29.6
Maritime		X		X	0.1	100	None	C/A-code	Pulse-Like	-112.6	-48.1	-23.2
Railway		X	X		0.1	100	None	C/A-code	Pulse-Like	-112.6	-56.3	-15
Railway		X		X	0.1	100	None	C/A-code	Pulse-Like	-112.6	-57.8	-13.5
Surveying	X			X	0.1	20	2% Rel.	Semi-Codeless	Noise-Like	-138	-81.1	9.8
Surveying		X		X	0.1	20	2% Rel.	Semi-Codeless	Noise-Like	-138	-81.2	9.9
Aviation-NPA		X		X	0.1	100	None	C/A-code	Pulse-Like	-112.6	-52.9	-18.4
Aviation-ER		X	X		Note 1	Note 1	Note 1	C/A-code	Noise-Like	-134.8	-76.6 <sup>2</sup>	5.3
Aviation-ER		X		X	Note 1	Note 1	Note 1	C/A-code	Noise-Like	-134.8	-85.6 <sup>2</sup>	14.3

**Notes:** En-Route Navigation (ER), Non-Precision Approach (NPA)

1. In this operational scenario, it is assumed that there is a large enough number of UWB devices such that independent of the individual UWB signal parameters, the aggregate effect causes noise-like interference.
2. This maximum allowable EIRP is based on a density of 200 UWB devices per square kilometer transmitting simultaneously.

**Table 4-10. Summary of Analysis Results (PRF = 1 MHz)**

Operational Scenario Description					UWB Signal Characteristics			GPS Receiver Architecture	Classification of Interfering Signal	Maximum Interference Threshold <sup>1</sup>	Maximum Allowable EIRP <sup>3</sup>	Comparison with the Current Part 15 Level (dB)
Application	UWB Single	UWB Multiple	UWB Indoor	UWB Outdoor	PRF (MHz)	Gating %	Mod.					
Terrestrial	X			X	1	100	None	C/A-code	CW-Like	-143.7	-104.3	33
Terrestrial	X			X	1	100	2% Rel.	C/A-code	Pulse-Like	-131	-91.6	20.3
Terrestrial		X	X		1	100	None	C/A-code	CW-Like	-143.7	-88.7	17.4
Terrestrial		X	X		1	20 & 100	Multiple	C/A-code	Noise-Like	-134.5	-85.5	14.2
Terrestrial		X		X	1	100	None	C/A-code	CW-Like	-143.7	-93.4	22.1
Terrestrial		X		X	1	20 & 100	Multiple	C/A-code	Noise-Like	-134.5	-90.2	18.9
Maritime		X	X		1	100	None	C/A-code	CW-Like	-143.7	-72.8	1.5
Maritime		X	X		1	20 & 100	Multiple	C/A-code	Noise-Like	-134.5	-69.6	-1.7
Maritime		X		X	1	100	None	C/A-code	CW-Like	-143.7	-79.2	7.9
Maritime		X		X	1	20 & 100	Multiple	C/A-code	Noise-Like	-134.5	-76	4.7
Railway		X	X		1	100	None	C/A-code	CW-Like	-143.7	-87.4	16.1
Railway		X	X		1	20 & 100	Multiple	C/A-code	Noise-Like	-134.5	-83	11.7
Railway		X		X	1	100	None	C/A-code	CW-Like	-143.7	-88.9	17.6
Railway		X		X	1	20 & 100	Multiple	C/A-code	Noise-Like	-134.5	-84.5	13.2
Surveying	X			X	1	100	50% Abs.	Semi-Codeless	Noise-Like	-151	-94.1	22.8
Surveying		X		X	1	100	50% Abs.	Semi-Codeless	Noise-Like	-151	-94.2	22.9
Aviation-NPA		X		X	1	100	None	C/A-code	CW-Like	-143.7	-84	12.7
Aviation-NPA		X		X	1	20 & 100	Multiple	C/A-code	Noise-Like	-134.5	-80.8	9.5
Aviation-ER		X	X		Note 2	Note 2	Note 2	C/A-code	Noise-Like	-134.8	-76.6 <sup>3</sup>	5.3
Aviation-ER		X		X	Note 2	Note 2	Note 2	C/A-code	Noise-Like	-134.8	-85.6 <sup>3</sup>	14.3

**Notes:** En-Route Navigation (ER), Non-Precision Approach (NPA)

1. When the interference effect has been classified as pulse-like or noise-like, the value is expressed in units of dBW/MHz. The value is expressed in units of dBW when the interference effect has been classified as being CW-like.

2. In this operational scenario, it is assumed that there is a large enough number of UWB devices, such that independent of the individual UWB signal parameters the aggregate effect causes noise-like interference.

3. This maximum allowable EIRP is based on a density of 200 UWB devices per square kilometer transmitting simultaneously.

**Table 4-11. Summary of Analysis Results (PRF = 5 MHz)**

Operational Scenario Description					UWB Signal Characteristics			GPS Receiver Architecture	Classification of Interfering Signal	Maximum Interference Threshold <sup>1</sup>	Maximum Allowable EIRP <sup>1</sup>	Comparison with the Current Part 15 Level (dB)
Application	UWB Single	UWB Multiple	UWB Indoor	UWB Outdoor	PRF (MHz)	Gating %	Mod.					
Terrestrial	X			X	5	100	None	C/A-code	CW-Like	-145.5	-106.1	34.8
Terrestrial	X			X	5	20	50% Abs.	C/A-code	Pulse-Like	-105	-65.6	-5.7
Terrestrial	X			X	5	100	50% Abs.	C/A-code	Noise-Like	-137	-97.6	26.3
Terrestrial		X	X		5	100	None	C/A-code	CW-Like	-145.5	-90.5	19.2
Terrestrial		X	X		5	100	50% Abs.	C/A-code	Noise-Like	-137	-88	16.7
Terrestrial		X		X	5	100	None	C/A-code	CW-Like	-145.5	-95.2	23.9
Terrestrial		X		X	5	100	50% Abs.	C/A-code	Noise-Like	-137	-92.7	21.4
Maritime		X	X		5	100	None	C/A-code	CW-Like	-145.5	-74.6	3.3
Maritime		X	X		5	100	50% Abs.	C/A-code	Noise-Like	-137	-72.1	0.8
Maritime		X		X	5	100	None	C/A-code	CW-Like	-145.5	-81	9.7
Maritime		X		X	5	100	50% Abs.	C/A-code	Noise-Like	-137	-78.5	7.2
Railway		X	X		5	100	None	C/A-code	CW-Like	-145.5	-89.2	17.9
Railway		X	X		5	100	50% Abs.	C/A-code	Noise-Like	-137	-85.5	14.2
Railway		X		X	5	100	None	C/A-code	CW-Like	-145.5	-90.7	19.4
Railway		X		X	5	100	50% Abs.	C/A-code	Noise-Like	-137	-87	15.7
Surveying	X			X	5	20 & 100	50% Abs.	Semi-Codeless	Noise-Like	-151	-94.1	22.8
Surveying		X		X	5	20 & 100	50% Abs.	Semi-Codeless	Noise-Like	-151	-94.2	22.9
Aviation-NPA		X		X	5	100	None	C/A-code	CW-Like	-145.5	-85.8	14.5
Aviation-NPA		X		X	5	100	50% Abs.	C/A-code	Noise-Like	-137	-83.3	12
Aviation-ER		X	X		Note 2	Note 2	Note 2	C/A-code	Noise-Like	-134.8	-76.6 <sup>3</sup>	5.3
Aviation-ER		X		X	Note 2	Note 2	Note 2	C/A-code	Noise-Like	-134.8	-85.6 <sup>3</sup>	14.3

**Notes:** En-Route Navigation (ER), Non-Precision Approach (NPA)  
 1. When the interference effect has been classified as pulse-like or noise-like, the value is expressed in units of dBW/MHz. The value is expressed in units of dBW when the interference effect has been classified as CW-like.  
 2. In this operational scenario, it is assumed that there is a large enough number of UWB devices, such that independent of the individual UWB signal parameters the aggregate effect causes noise-like interference.  
 3. This maximum allowable EIRP is based on a density of 200 UWB devices per square kilometer transmitting simultaneously.

**Table 4-12. Summary of Analysis Results (PRF = 20 MHz)**

Operational Scenario Description					UWB Signal Characteristics			GPS Receiver Architecture	Classification of Interfering Signal	Maximum Interference Threshold <sup>1</sup>	Maximum Allowable EIRP <sup>1</sup>	Comparison with the Current Part 15 Level (dB)
Application	UWB Single	UWB Multiple	UWB Indoor	UWB Outdoor	PRF (MHz)	Gating %	Mod.					
Terrestrial	X			X	20	20	OOK	C/A-code	CW-Like	-146.3	-106.9	35.6
Terrestrial	X			X	20	20	50% Abs.	C/A-code	Pulse-Like	-135	-95.6	24.3
Terrestrial	X			X	20	100	50% Abs.	C/A-code	Noise-Like	-138	-98.6	27.3
Terrestrial		X	X		20	20	OOK	C/A-code	CW-Like	-146.3	-91.3	20
Terrestrial		X	X		20	100	50% Abs.	C/A-code	Noise-Like	-138	-89	17.7
Terrestrial		X		X	20	20	OOK	C/A-code	CW-Like	-146.3	-96	24.7
Terrestrial		X		X	20	100	50% Abs.	C/A-code	Noise-Like	-138	-93.7	22.4
Maritime		X	X		20	20	OOK	C/A-code	CW-Like	-145	-75.4	4.1
Maritime		X	X		5	100	50% Abs.	C/A-code	Noise-Like	-138	-73.1	1.8
Maritime		X		X	20	20	OOK	C/A-code	CW-Like	-145	-81.8	10.5
Maritime		X		X	20	100	50% Abs.	C/A-code	Noise-Like	-138	-79.5	8.2
Railway		X	X		20	20	OOK	C/A-code	CW-Like	-145	-90	18.7
Railway		X	X		20	100	50% Abs.	C/A-code	Noise-Like	-138	-86.5	15.2
Railway		X		X	20	20	OOK	C/A-code	CW-Like	-145	-91.5	20.2
Railway		X		X	20	100	50% Abs.	C/A-code	Noise-Like	-138	-88	16.7
Surveying	X			X	20	100	50% Abs. & 2% Rel.	Semi-Codeless	Noise-Like	-149.5	-92.6	21.3
Surveying		X		X	20	100	50% Abs. & 2% Rel.	Semi-Codeless	Noise-Like	-149.5	-92.7	21.4
Aviation-NPA		X		X	20	20	OOK	C/A-code	CW-Like	-145	-86.6	15.3
Aviation-NPA		X		X	20	100	50% Abs.	C/A-code	Noise-Like	-138	-84.3	13
Aviation-ER		X	X		Note 2	Note 2	Note 2	C/A-code	Noise-Like	-134.8	-76.6 <sup>3</sup>	5.3
Aviation-ER		X		X	Note 2	Note 2	Note 2	C/A-code	Noise-Like	-134.8	-85.6 <sup>3</sup>	14.3

**Notes:** En-Route Navigation (ER), Non-Precision Approach (NPA)

1. When the interference effect has been classified as pulse-like or noise-like, the value is expressed in units of dBW/MHz. The value is expressed in units of dBW when the interference effect has been classified as being CW-like.

2. In this operational scenario, it is assumed that there is a large enough number of UWB devices, such that independent of the individual UWB signal parameters the aggregate effect causes noise-like interference.

3. This maximum allowable EIRP is based on a density of 200 UWB devices per square kilometer transmitting simultaneously.

Certain observations were made based on a review of the last column in Tables 4-9 through 4-12. This column lists the difference between the current Part 15 level of -71.3 dBW/MHz (considered as an average power limit) and the computed maximum allowable EIRP values. A positive number in the last column indicates that the computed allowable EIRP is less than the current Part 15 level.

An examination of Table 4-9 (PRF = 100 kHz) shows the effect of the C/A-code signal process being fairly robust to low-duty cycle pulsed interference. The worse-case comparison to the current Part 15 level for the C/A-code architecture is the aviation en-route navigation operational scenario with UWB devices operating outdoors (14.3 dB below the Part 15 level). This is based on a density of active UWB devices of 200/km<sup>2</sup>. If one considers the use of 100 kHz PRF could be of interest in only UWB device applications such as ground penetrating radars and through-the-wall imaging radars, the projected density of UWB devices may not be high, as the use of such devices could be limited. If, for example, the density of UWB devices operating at 100 kHz is 20/km<sup>2</sup>, the maximum allowable EIRP would increase by 10 dB. That is the comparison to the Part 15 level would be 4.3 dB for the aviation en-route navigation operational scenario with UWB devices operating outdoors and a limit of 10 dB below the current Part 15 level could be appropriate for all C/A-code uses at 100 kHz.

The 100 kHz PRF also shows the effect of the use of semi-codeless receiver architecture in the surveying operational scenario. It should be noted that surveyors are not the only users of GPS receiver employing semi-codeless techniques. The result of the use of semi-codeless receivers is extremely beneficial in applications for GPS reference stations, high accuracy distance and location measurements (i.e., low dynamic applications). However, the semi-codeless process is inherently more susceptible to interference that is classified as pulsed-like or noise-like, than the C/A-code process (the signal processing is not usually as effective and the P-code signals are not as strong as the C/A-code signal). The results of the analysis for the surveying operational scenario shows the UWB signals would need to be 10 dB below the current Part 15 level to protect the semi-codeless receiver architecture.

Tables 2 through 4 (UWB waveforms with PRFs of 1, 5, and 20 MHz) show that the maximum allowable EIRP level necessary to satisfy the measured GPS performance criteria must be less than the current Part 15 level for most of the operational scenarios considered. Those interactions that involve operational scenario/UWB signal parameter combinations that require an attenuation of 20 dB or more below the Part 15 level were selected for closer inspection. This examination indicates that in most of these cases, the interactions involve: 1) UWB waveforms that were deemed CW-like in their interference effect to the GPS C/A-code receiver architecture, for which the measurements indicate a greater interference susceptibility; 2) applications using semi-codeless receivers, which were determined from the measurements to be more susceptible to UWB waveforms classified as noise-like or pulse-like interference; or 3) operational scenarios in which the UWB transmitter is considered to be operating at a close distance (within several meters) relative to the GPS receiver. This data suggests that if the spectral line content of the UWB waveforms could be removed from consideration, perhaps through regulation, there still remains a number of interactions involving noise-like UWB waveforms at these PRFs for which the EIRP levels would have to be attenuated to levels up to 27 dB below the current Part 15 level.

As shown in Tables 4-9 through 4-12, the results of the analysis indicate that the values of maximum allowable EIRP that are necessary to preclude interference to GPS receivers is highly dependent on the parameters of the UWB signal. This is consistent with the findings from the measurement effort where the performance of the GPS receiver in the presence of a UWB signal was also found to be highly dependent on the UWB signal structure. Figures 4-2 through 4-5 display computed maximum allowable EIRP levels for those UWB signal permutations that were classified within this study as pulse-like, noise-like, and CW-like with respect to their interference effects on the GPS C/A-code receiver. The values reported in these charts represent the maximum allowable EIRP level determined from an analysis of each UWB signal permutation in potential interactions with the GPS C/A-code receiver that were defined by all of the operational scenarios considered in the study

For the operational scenarios that considered multiple UWB devices, Figure 4-2 displays the range maximum allowable EIRP for the UWB signal structures that were classified within this study as pulse-like. Figure 4-4 presents the range of maximum allowable EIRP levels for those UWB waveforms that were classified as noise-like when considered in the analysis based on the operational scenarios. Figure 4-5 presents the range of maximum allowable EIRP levels for those UWB signals that were classified as CW-like in their effects on the GPS C/A-code receiver examined in this study. The labels on the y-axis in Figures 4-2 through 4-5 identify the various UWB signal structures in terms of PRF, percent gating, and type of modulation. For example, a UWB signal structure with a PRF of 100 kHz, 100% gating, and no modulation will have a y-axis label of: 100 kHz, 100%, None.

Figure 4-3 shows those pulse-like interference cases for which a range of EIRP values was not determined in the analysis. These cases involve UWB parameters that cause pulse-like interference in the operational scenario that considered a single UWB device, but result in noise-like interference in the operational scenarios that considered multiple UWB devices. For the C/A code receiver architecture, there was only one scenario considered in the analysis (Single UWB Device Terrestrial Operational Scenario) that involved a single UWB device. Thus only a single EIRP value is shown in Figure 4-3.

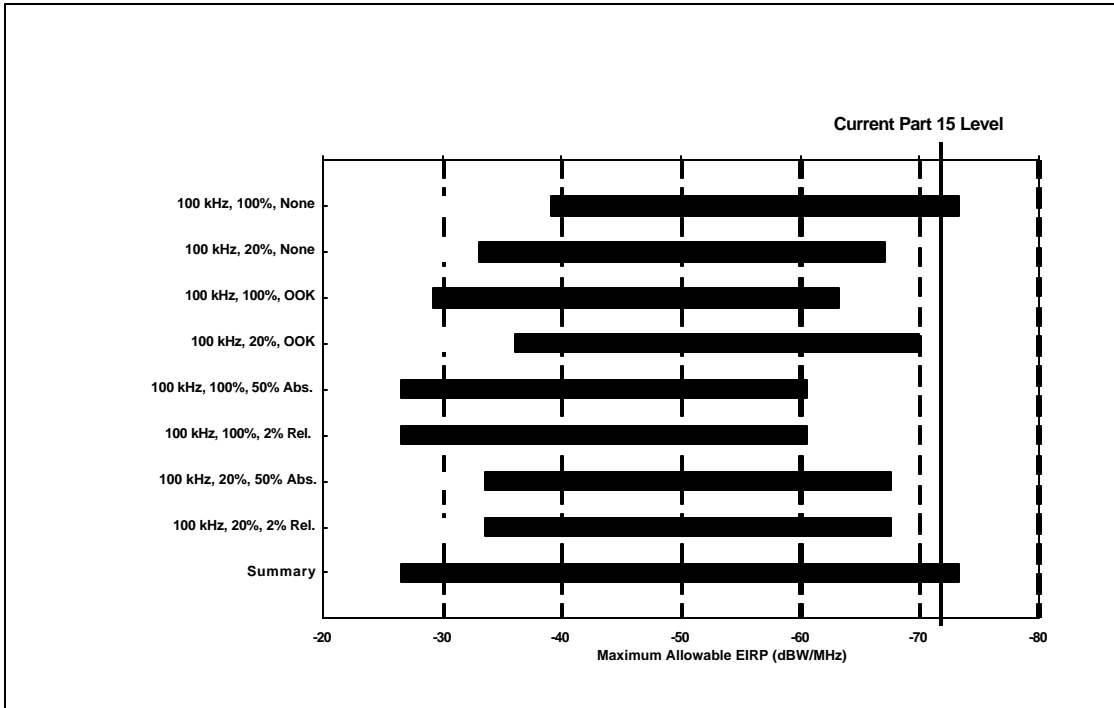


Figure 4-2. Range of Maximum Allowable EIRP for Pulse-Like UWB Signal Structures for the C/A-code Receiver Architecture (Multiple UWB Device Operational Scenarios)

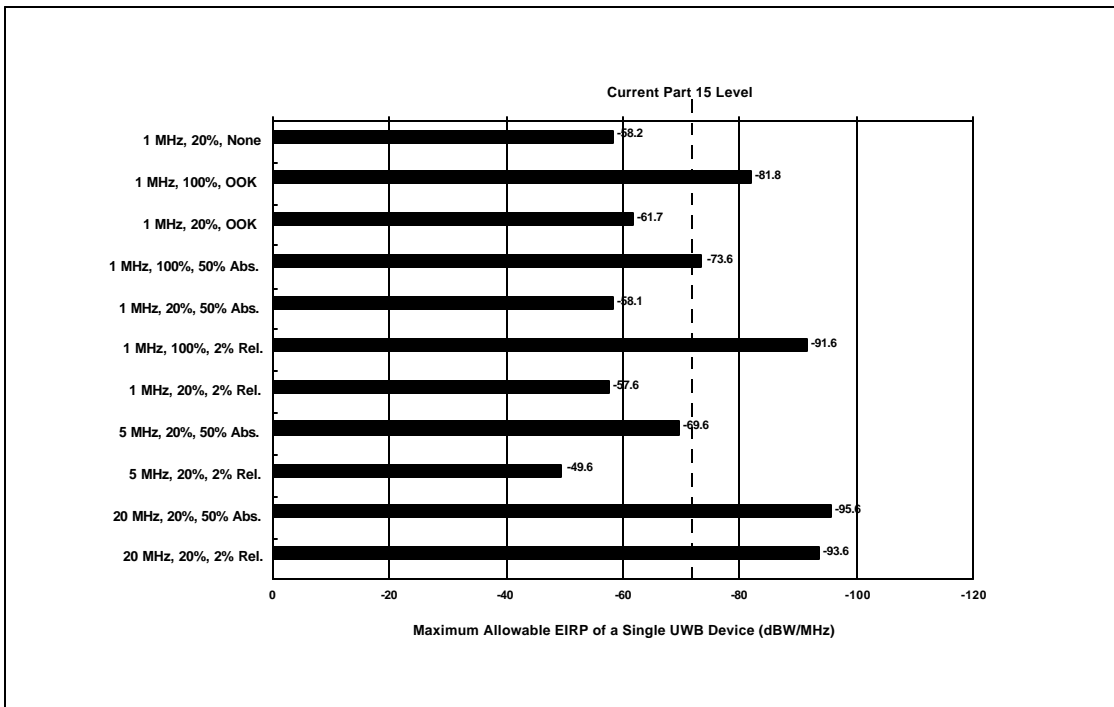
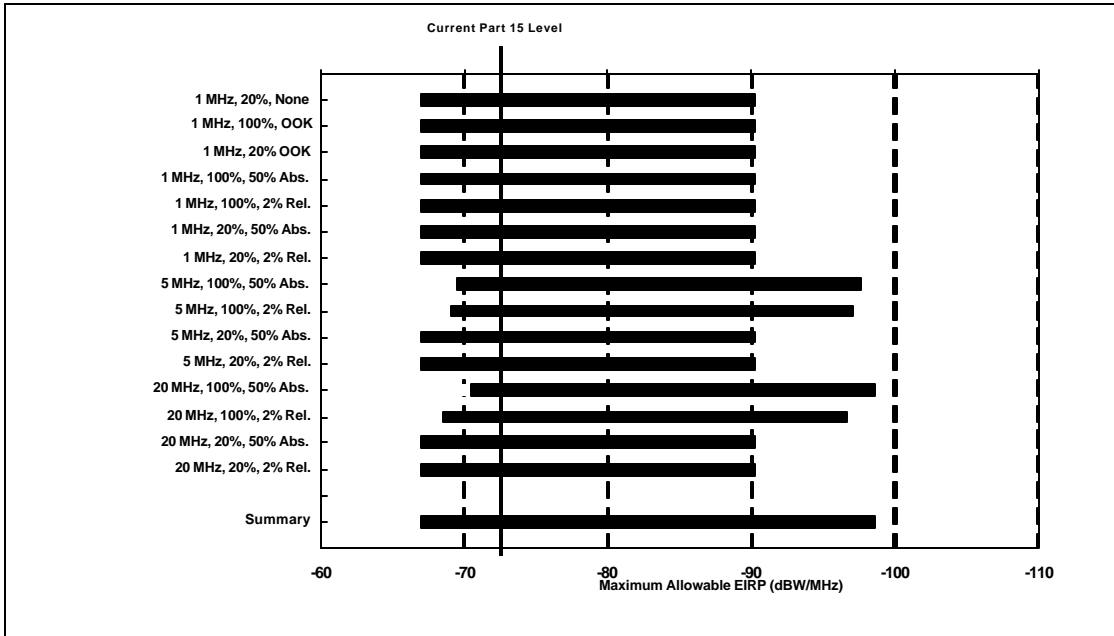
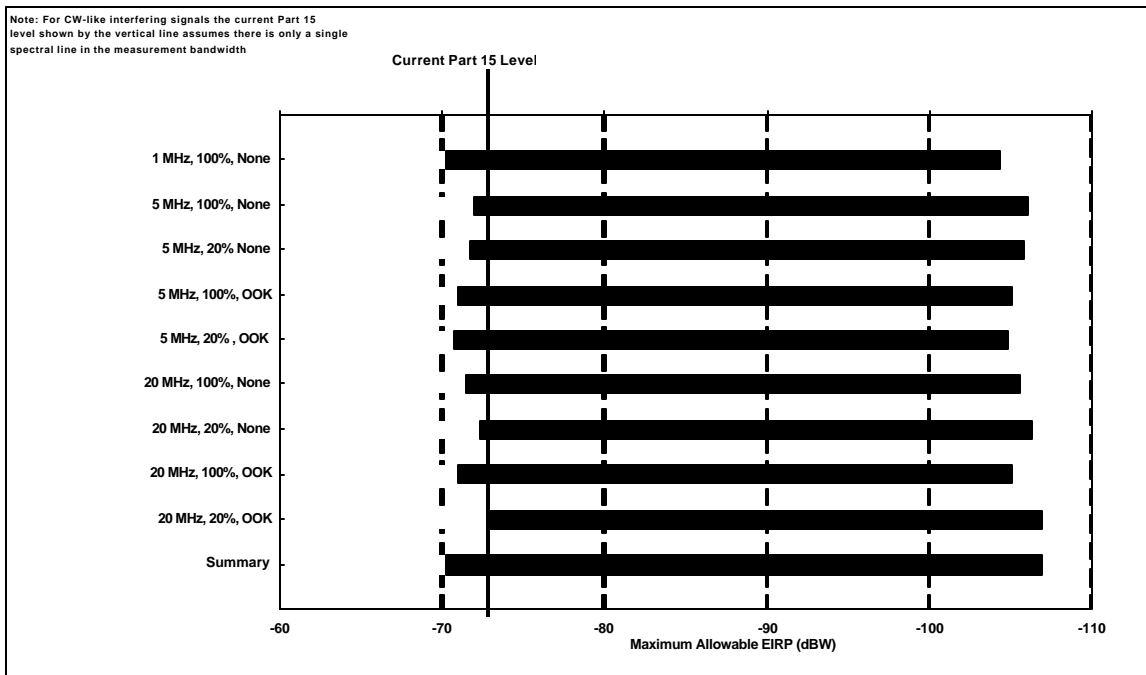


Figure 4-3. Maximum Allowable EIRP for Pulse-Like UWB Signal Structures for the C/A-code Receiver Architecture (Single UWB Device Operational Scenario)





**Figure 4-4. Range of Maximum Allowable EIRP for Noise-Like UWB Signal Structures for the C/A-code Receiver Architecture (Multiple UWB Device Operational Scenarios)**



**Figure 4-5. Range of Maximum Allowable EIRP for CW-Like UWB Signal Structures for the C/A-code Receiver Architecture (Multiple UWB Device Operational Scenarios)**

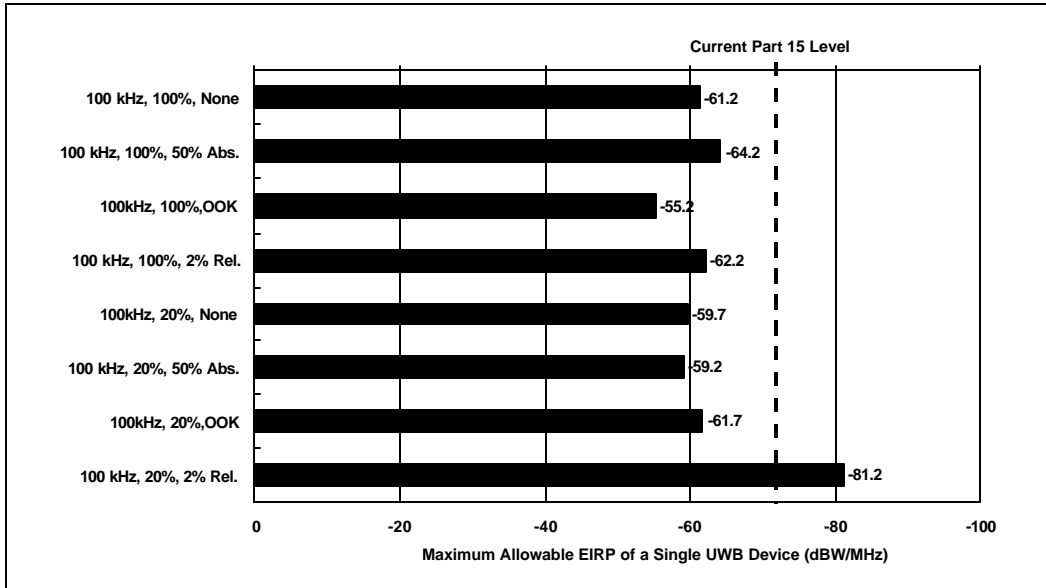
An examination of Figures 4-2 through 4-5 indicates that the maximum allowable EIRP levels required to satisfy the measured performance threshold of the GPS C/A-code receiver, across all of the operational scenarios, is a function of the PRF of the UWB device. Figure 4-2 shows that the maximum allowable EIRP levels corresponding to those UWB signal permutations with a PRF of 100 kHz. The EIRP levels shown in this figure for the unmodulated, 100% gated UWB waveform was computer based on a measured break-lock threshold. For the remaining UWB signal permutations represented in the figure, neither a break-lock nor a reacquisition could be measured for UWB power levels up to the maximum power available from the UWB signal generator. For these cases, the maximum UWB signal generator power level was used to compute the EIRP level. Thus the reported EIRP level represents a lower limit for these cases. That is, the actual maximum allowable EIRP level may higher than the level shown in the figure for these 100 kHz PRF UWB waveforms. From Figure 4-2, it can be observed that the maximum EIRP levels necessary to satisfy the measured performance threshold for the C/A-code GPS receiver over all of the operational scenarios considered in this study range from -73.2 to -26.5 dBW/MHz.

Figure 4-4 shows that the maximum allowable EIRP levels necessary to satisfy the measured performance thresholds over all of the operational scenarios considered in this study range from -98.6 to -67.0 dBW/MHz for those UWB signals employing PRFs of 1 MHz, 5 MHz, and 20 MHz, that are classified as noise-like in their interference effects to the GPS C/A-code receiver.

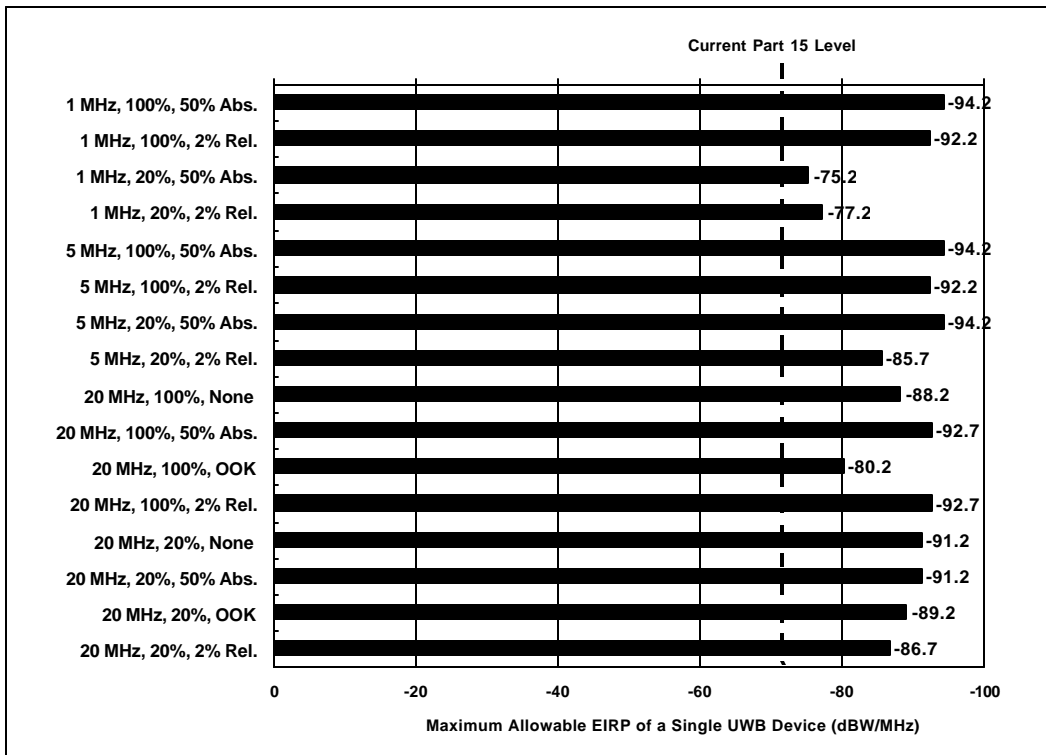
The data presented in Figure 4-5 shows that the maximum allowable EIRP levels range from -106.9 to -70.2 dBW over all of the operational scenarios considered for those UWB signals that are classified as CW-like in their interference effects on the GPS C/A-code receiver. These EIRP levels are based on the power in a single spectral line and in order to compare to the Part 15 level, it must be assumed that only a single spectral line appears in the measurement bandwidth.

Figures 4-6 and 4-7 present summary plots showing the maximum allowable EIRP calculated for the surveying operational scenarios assuming the use of the semi-codeless receiver architecture measured in this study. The analysis results are presented as a function of the various UWB signal structures examined. For the semi-codeless receiver architecture, the interference effects of all of the UWB signals examined are classified as either pulse-like or noise-like. Figure 4-6 shows that for those UWB signals examined with a PRF of 100 kHz, the calculated maximum level EIRP is above the current Part 15 emission level (i.e. no additional attenuation is necessary) with one exception: the 20% gated, 2% relative dithered signal.

Figure 4-7 shows the for the PRF's of 1 MHz, 5 MHz, and 20 MHz, those UWB signal structures that were classified as noise-like, the maximum allowable EIRP level must be as much as 23 dB below the current Part 15 level to satisfy the measured performance threshold of the semi-codeless GPS receiver in the applicable operational scenarios. The measurements of the semi-codeless receiver indicate a relative immunity to CW-like interference effects. This is because the semi-codeless receiver architecture uses the P-code signal which, because of its longer code length, has essentially no spectral lines.



**Figure 4-5. Maximum Allowable EIRP as a Function of UWB Signal Structure for the Semi-Codeless Receiver Architecture (Pulse-Like UWB Signals)**



**Figure 4-6. Maximum Allowable EIRP as a Function of UWB Signal Structure for the Semi-Codeless Receiver Architecture (Noise-Like UWB Signals)**

## 4.3 CONCLUSIONS

The data collected in this assessment demonstrates that when considered in potential interactions with GPS receivers used in applications represented by the operational scenarios considered in this study, some of the UWB signal permutations examined exceeded the measured GPS performance thresholds at EIRP levels well below the current Part 15 emission level. Likewise, other UWB signal permutations (e.g., the 100 kHz PRF UWB signals) only slightly exceeded, and in some cases did not exceed, the measured GPS performance thresholds when considered in potential interactions with GPS receivers defined by the operational scenarios considered as a part of this study.

The following general conclusions were drawn based on the findings of this study:

- 1) The GPS receiver performance thresholds measured within this study are consistent with the interference protection limits developed within national and international GPS study groups.
- 2) When multiple noise-like UWB signals with equivalent power levels at the GPS receiver input are considered, the effective aggregate signal level in the receiver IF bandwidth is determined by adding the average power of each of the UWB signals.
- 3) Within the limitations of this study (i.e., the available number of UWB signal generators), it was found that when multiple CW-like UWB signals are considered, the effective aggregate interference effect to a C/A-code GPS receiver is the same as that of a single CW-like signal. The interference mechanism is a result of the alignment of a UWB spectral line with a dominant GPS C/A-code line.
- 4) The CW-like interference effect is not applicable to the semi-codeless receiver examined when operating in the dual frequency mode.
- 5) A GPS antenna does not offer any additional attenuation to that portion of a UWB signal within the GPS frequency band.
- 6) For those UWB signals examined with a PRF of 100 kHz, maximum permissible EIRP levels between -73.2 and -26.5 dBW/MHz are necessary to ensure EMC with the GPS applications defined by the operational scenarios considered within this study.
- 7) For those UWB signals examined with a PRF of 1 MHz, the maximum allowable EIRP levels necessary to achieve EMC with the GPS receiver applications considered in this study range from -70.2 to -104.3 dBW for the CW-like (unmodulated) UWB waveforms, and -57.6 to -91.6 dBW/MHz for the noise-like (modulated and/or dithered) UWB waveforms.
- 8) For those UWB signals examined with a PRF of 5 MHz, the maximum allowable EIRP levels necessary to ensure EMC with the GPS receiver applications considered in this study range from

-70.7 to -106.1 dBW for the CW-like (non-dithered) UWB waveforms, and from -49.6 to -97.6 dBW/MHz for the noise-like (dithered) UWB waveforms.

9) For those UWB signals examined with a PRF of 20 MHz, the maximum allowable EIRP levels required to ensure EMC with all of the GPS receiver applications considered in this study range from -71.0 to -106.9 dBW for the CW-like (non-dithered) UWB waveforms, and from -60.0 to -98.6 dBW/MHz for the noise-like (dithered) UWB waveforms.

It must be noted that these results are applicable only to those UWB signal permutations examined within this study and to those applications of GPS that are defined by the operational scenarios presented for consideration herein.

# APPENDIX A

## Derivation of Equations for Aggregate Effects Of UWB Devices in the Non-Precision Approach Landing Operational Scenario

This appendix provides the derivation of the equations used to compute the aggregate effects of UWB devices in the non-precision approach operational scenario. The parameters used to derive the equations are shown in Figure A-1.

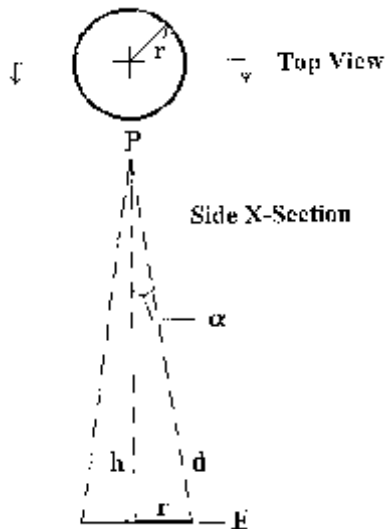


Figure A-1

The parameters in Figure A-1 are defined as:

Point P is the airborne GPS receiver antenna;

Surface E is the plane containing the interfering sources;

h is the minimum distance from point P to plane E

d is the distance from points on plane E whose propagation loss differs from the minimum loss at distance h by a fixed pathloss ratio LR;

r is the radius circle containing the points of the fixed pathloss ratio; and

$\alpha$  is the angle between lines h and d.

$$\text{Let } d/h = (\text{LR})^{0.5}$$

Then

$$d^2 = r^2 + h^2 = h^2 (\text{LR})$$

$$r^2 = h^2 (\text{LR}) - h^2$$

$$r^2 = h^2 (\text{LR}-1)$$

The radius of the circle containing the interfering sources is given by:

$$r = h (\text{LR}-1)^{0.5}$$

To derive the equation for computing the angle  $\acute{a}$  use the trigonometric relationship for the cosine:

$$\cos \acute{a} = h/d$$

$$\acute{a} = \cos^{-1} (h/d) = \cos^{-1} (1/(\text{LR})^{0.5})$$

The pathloss is proportional to  $20 \text{ Log } d = 20 \text{ Log } (h(\text{LR})^{0.5})$ . This can be rewritten as

$$20 \text{ Log } d = 20 \text{ Log } h + 10 \text{ Log } \text{LR}$$

**Appendix B**  
**Results of Spreadsheet Analysis Program**



**Operational Scenario: Terrestrial GPS Receiver and Single UWB Device**  
**GPS Receiver Architecture: C/A-code**

			Imax (dBW/MHz)	Hgps (m)	Huw b (m)	Hsep (m)	Theta (deg)	Gr (dBic)	Dmin (m)	Lp (dB)	Lmul t (dB)	Lallot (dB)	Lman (dB)	Laf (dB)	Lba (dB)	Lsm (dB)	UWB EIRP (dBW/MHz)	GPS Receiver Criteria
<b>Broadband Noise</b>			-134.5	3	3	2	0	0	2	42.4	0	0	3	0	0	0	-95.1	RQT
UWB PRF	UWB Gating	UWB Mod	Imax (dBW)	Hgps (m)	Huw b (m)	Hsep (m)	Theta (deg)	Gr (dBic)	Dmin (m)	Lp (dB)	Lmul t (dB)	Lallot (dB)	Lman (dB)	Laf (dB)	Lba (dB)	Lsm (dB)	UWB EIRP (dBW)	GPS Receiver Criteria
1 MHz	100%	None	-143.7	3	3	2	0	0	2	42.4	0	0	3	0	0	0	-104.3	BL
5 MHz	100%	None	-145.5	3	3	2	0	0	2	42.4	0	0	3	0	0	0	-106.1	BL
20 MHz	100%	None	-145	3	3	2	0	0	2	42.4	0	0	3	0	0	0	-105.6	BL
5 MHz	20%	None	-145.2	3	3	2	0	0	2	42.4	0	0	3	0	0	0	-105.8	BL
20 MHz	20%	None	-145.8	3	3	2	0	0	2	42.4	0	0	3	0	0	0	-106.4	BL
5 MHz	100%	OOK	-144.5	3	3	2	0	0	2	42.4	0	0	3	0	0	0	-105.1	BL
20 MHz	100%	OOK	-144.5	3	3	2	0	0	2	42.4	0	0	3	0	0	0	-105.1	BL
5 MHz	20%	OOK	-144.2	3	3	2	0	0	2	42.4	0	0	3	0	0	0	-104.8	BL
20 MHz	20%	OOK	-146.3	3	3	2	0	0	2	42.4	0	0	3	0	0	0	-106.9	BL
UWB PRF	UWB Gating	UWB Mod	Imax (dBW/MHz)	Hgps (m)	Huw b (m)	Hsep (m)	Theta (deg)	Gr (dBic)	Dmin (m)	Lp (dB)	Lmul t (dB)	Lallot (dB)	Lman (dB)	Laf (dB)	Lba (dB)	Lsm (dB)	UWB EIRP (dBW/MHz)	GPS Receiver Criteria
100 kHz	100%	None	-112.6	3	3	2	0	0	2	42.4	0	0	3	0	0	0	-73.2	BL
100 kHz	20%	None	-106.5	3	3	2	0	0	2	42.4	0	0	3	0	0	0	-67.1	DNBL
1 MHz	20%	None	-97.6	3	3	2	0	0	2	42.4	0	0	3	0	0	0	-58.2	DNBL
100 kHz	100%	OOK	-102.6	3	3	2	0	0	2	42.4	0	0	3	0	0	0	-63.2	DNBL
1 MHz	100%	OOK	-121.2	3	3	2	0	0	2	42.4	0	0	3	0	0	0	-81.8	BL
100 kHz	20%	OOK	-109.4	3	3	2	0	0	2	42.4	0	0	3	0	0	0	-70.0	DNBL
1 MHz	20%	OOK	-101.1	3	3	2	0	0	2	42.4	0	0	3	0	0	0	-61.7	DNBL
100 kHz	100%	50% Abs.	-100	3	3	2	0	0	2	42.4	0	0	3	0	0	0	-60.6	DNBL
1 MHz	100%	50% Abs.	-113	3	3	2	0	0	2	42.4	0	0	3	0	0	0	-73.6	RQT
5 MHz	100%	50% Abs.	-137	3	3	2	0	0	2	42.4	0	0	3	0	0	0	-97.6	RQT
20 MHz	100%	50% Abs.	-138	3	3	2	0	0	2	42.4	0	0	3	0	0	0	-98.6	RQT
100 kHz	100%	2% Rel.	-100	3	3	2	0	0	2	42.4	0	0	3	0	0	0	-60.6	DNBL
1 MHz	100%	2% Rel.	-131	3	3	2	0	0	2	42.4	0	0	3	0	0	0	-91.6	RQT
5 MHz	100%	2% Rel.	-136.5	3	3	2	0	0	2	42.4	0	0	3	0	0	0	-97.1	RQT
20 MHz	100%	2% Rel.	-136	3	3	2	0	0	2	42.4	0	0	3	0	0	0	-96.6	RQT
100 kHz	20%	50% Abs.	-107	3	3	2	0	0	2	42.4	0	0	3	0	0	0	-67.6	DNBL
1 MHz	20%	50% Abs.	-97.5	3	3	2	0	0	2	42.4	0	0	3	0	0	0	-58.1	DNBL
5 MHz	20%	50% Abs.	-105	3	3	2	0	0	2	42.4	0	0	3	0	0	0	-65.6	RQT
20 MHz	20%	50% Abs.	-135	3	3	2	0	0	2	42.4	0	0	3	0	0	0	-95.6	RQT
100 kHz	20%	2% Rel.	-107	3	3	2	0	0	2	42.4	0	0	3	0	0	0	-67.6	DNBL
1 MHz	20%	2% Rel.	-97	3	3	2	0	0	2	42.4	0	0	3	0	0	0	-57.6	RQT
5 MHz	20%	2% Rel.	-89	3	3	2	0	0	2	42.4	0	0	3	0	0	0	-49.6	DNBL
20 MHz	20%	2% Rel.	-133	3	3	2	0	0	2	42.4	0	0	3	0	0	0	-93.6	RQT

BL - Break-Lock

RQT - Reacquisition Time

DNBL - Did not break-lock at the maximum UWB generator signal power

**Operational Scenario: Terrestrial GPS Receiver and Multiple UWB Device  
(Outdoor Operation)  
GPS Receiver Architecture: C/A-code**

			$I_{max}$ (dBW/MHz)	Hgps (m)	Huwb (m)	Hsep (m)	Theta (deg)	Gr (dBic)	Dmin (m)	Lp (dB)	Lmul t (dB)	Lallot (dB)	Lman (dB)	Laf (dB)	Lba (dB)	Lsm (dB)	UWB EIRP (dBW/MHz)	Single Entry GPS Receiver Criteria
<b>Broadband Noise</b>			-134.5	3	3	10	0	0	10	56.4	6	3	3	0	0	0	-90.2	RQT
UWB PRF	UWB Gating	UWB Mod.	$I_{max}$ (dBW)	Hgps (m)	Huwb (m)	Hsep (m)	Theta (deg)	Gr (dBic)	Dmin (m)	Lp (dB)	Lmul t (dB)	Lallot (dB)	Lman (dB)	Laf (dB)	Lba (dB)	Lsm (dB)	UWB EIRP (dBW)	GPS Receiver Criteria
1 MHz	100%	None	-143.7	3	3	10	0	0	10	56.4	0	3	3	0	0	0	-93.4	BL
5 MHz	100%	None	-145.5	3	3	10	0	0	10	56.4	0	3	3	0	0	0	-95.2	BL
20 MHz	100%	None	-145	3	3	10	0	0	10	56.4	0	3	3	0	0	0	-94.7	BL
5 MHz	20%	None	-145.2	3	3	10	0	0	10	56.4	0	3	3	0	0	0	-94.9	BL
20 MHz	20%	None	-145.8	3	3	10	0	0	10	56.4	0	3	3	0	0	0	-95.5	BL
5 MHz	100%	OOK	-144.5	3	3	10	0	0	10	56.4	0	3	3	0	0	0	-94.2	BL
20 MHz	100%	OOK	-144.5	3	3	10	0	0	10	56.4	0	3	3	0	0	0	-94.2	BL
5 MHz	20%	OOK	-144.2	3	3	10	0	0	10	56.4	0	3	3	0	0	0	-93.9	BL
20 MHz	20%	OOK	-146.3	3	3	10	0	0	10	56.4	0	3	3	0	0	0	-96.0	BL
100 kHz	100%	None	-112.6	3	3	10	0	0	10	56.4	0	3	3	0	0	0	-62.3	BL
100 kHz	20%	None	-106.5	3	3	10	0	0	10	56.4	0	3	3	0	0	0	-56.2	DNBL
1 MHz	20%	None	-134.5	3	3	10	0	0	10	56.4	6	3	3	0	0	0	-90.2	NRQT
100 kHz	100%	OOK	-102.6	3	3	10	0	0	10	56.4	0	3	3	0	0	0	-53.3	DNBL
1 MHz	100%	OOK	-134.5	3	3	10	0	0	10	56.4	6	3	3	0	0	0	-90.2	NRQT
100 kHz	20%	OOK	-109.4	3	3	10	0	0	10	56.4	0	3	3	0	0	0	-59.1	DNBL
1 MHz	20%	OOK	-134.5	3	3	10	0	0	10	56.4	6	3	3	0	0	0	-90.2	NRQT
100 kHz	100%	50% Abs.	-100	3	3	10	0	0	10	56.4	0	3	3	0	0	0	-49.7	DNBL
1 MHz	100%	50% Abs.	-134.5	3	3	10	0	0	10	56.4	6	3	3	0	0	0	-90.2	NRQT
5 MHz	100%	50% Abs.	-137	3	3	10	0	0	10	56.4	6	3	3	0	0	0	-92.7	RQT
20 MHz	100%	50% Abs.	-138	3	3	10	0	0	10	56.4	6	3	3	0	0	0	-93.7	RQT
100 kHz	100%	2% Rel.	-100	3	3	10	0	0	10	56.4	0	3	3	0	0	0	-49.7	DNBL
1 MHz	100%	2% Rel.	-134.5	3	3	10	0	0	10	56.4	6	3	3	0	0	0	-90.2	NRQT
5 MHz	100%	2% Rel.	-136.5	3	3	10	0	0	10	56.4	6	3	3	0	0	0	-92.2	RQT
20 MHz	100%	2% Rel.	-136	3	3	10	0	0	10	56.4	6	3	3	0	0	0	-91.7	RQT
100 kHz	20%	50% Abs.	-107	3	3	10	0	0	10	56.4	0	3	3	0	0	0	-56.7	DNBL
1 MHz	20%	50% Abs.	-134.5	3	3	10	0	0	10	56.4	6	3	3	0	0	0	-90.2	NRQT
5 MHz	20%	50% Abs.	-134.5	3	3	10	0	0	10	56.4	6	3	3	0	0	0	-90.2	NRQT
20 MHz	20%	50% Abs.	-134.5	3	3	10	0	0	10	56.4	6	3	3	0	0	0	-90.2	NRQT
100 kHz	20%	2% Rel.	-107	3	3	10	0	0	10	56.4	0	3	3	0	0	0	-56.7	DNBL
1 MHz	20%	2% Rel.	-134.5	3	3	10	0	0	10	56.4	6	3	3	0	0	0	-90.2	NRQT
5 MHz	20%	2% Rel.	-134.5	3	3	10	0	0	10	56.4	6	3	3	0	0	0	-90.2	NRQT
20 MHz	20%	2% Rel.	-134.5	3	3	10	0	0	10	56.4	6	3	3	0	0	0	-90.2	NRQT

BL - Break-lock

RQT-Reacquisition Time

DNBL- Did not break lock at the maximum available UWB generator signal power

NRQT - Broadband Noise Reacquisition

**Operational Scenario: Terrestrial GPS Receiver and Multiple UWB Device (Indoor Operation)**  
**GPS Receiver Architecture: C/A-code**

			I <sub>max</sub> (dBW/MHz)	H <sub>gps</sub> (m)	H <sub>uw</sub> b (m)	H <sub>sep</sub> (m)	Theta (deg)	Gr (dBic)	D <sub>min</sub> (m)	L <sub>p</sub> (dB)	L <sub>mul</sub> t (dB)	L <sub>allot</sub> (dB)	L <sub>man</sub> (dB)	L <sub>af</sub> (dB)	L <sub>ba</sub> (dB)	L <sub>sm</sub> (dB)	UWB EIRP (dBW/MHz)	Single Entry GPS Receiver Criteria RQT
<b>Broadband Noise</b>																		
UWB PRF	UWB Gating	UWB Mod.	I <sub>max</sub> (dBW)	H <sub>gps</sub> (m)	H <sub>uw</sub> b (m)	H <sub>sep</sub> (m)	Theta (deg)	Gr (dBic)	D <sub>min</sub> (m)	L <sub>p</sub> (dB)	L <sub>mul</sub> t (dB)	L <sub>allot</sub> (dB)	L <sub>man</sub> (dB)	L <sub>af</sub> (dB)	L <sub>ba</sub> (dB)	L <sub>sm</sub> (dB)	UWB EIRP (dBW)	
1 MHz	100%	None	-143.7	3	10	5	54.5	3	8.6	55.0	0	3	3	0	9	0	-88.7	BL
5 MHz	100%	None	-145.5	3	10	5	54.5	3	8.6	55.0	0	3	3	0	9	0	-90.5	BL
20 MHz	100%	None	-145	3	10	5	54.5	3	8.6	55.0	0	3	3	0	9	0	-90.0	BL
5 MHz	20%	None	-145.2	3	10	5	54.5	3	8.6	55.0	0	3	3	0	9	0	-90.2	BL
20 MHz	20%	None	-145.8	3	10	5	54.5	3	8.6	55.0	0	3	3	0	9	0	-90.8	BL
5 MHz	100%	OOK	-144.5	3	10	5	54.5	3	8.6	55.0	0	3	3	0	9	0	-89.5	BL
20 MHz	100%	OOK	-144.5	3	10	5	54.5	3	8.6	55.0	0	3	3	0	9	0	-89.5	BL
5 MHz	20%	OOK	-144.2	3	10	5	54.5	3	8.6	55.0	0	3	3	0	9	0	-89.2	BL
20 MHz	20%	OOK	-146.3	3	10	5	54.5	3	8.6	55.0	0	3	3	0	9	0	-91.3	BL
UWB PRF	UWB Gating	UWB Mod.	I <sub>max</sub> (dBW/MHz)	H <sub>gps</sub> (m)	H <sub>uw</sub> b (m)	H <sub>sep</sub> (m)	Theta (deg)	Gr (dBic)	D <sub>min</sub> (m)	L <sub>p</sub> (dB)	L <sub>mul</sub> t (dB)	L <sub>allot</sub> (dB)	L <sub>man</sub> (dB)	L <sub>af</sub> (dB)	L <sub>ba</sub> (dB)	L <sub>sm</sub> (dB)	UWB EIRP (dBW/MHz)	Single Entry GPS Receiver Criteria
100 kHz	100%	None	-112.6	3	10	5	54.5	3	8.6	55.0	0	3	3	0	9	0	-57.6	BL
100 kHz	20%	None	-106.5	3	10	5	54.5	3	8.6	55.0	0	3	3	0	9	0	-51.5	DNBL
1 MHz	20%	None	-134.5	3	10	5	54.5	3	8.6	55.0	6	3	3	0	9	0	-85.5	NRQT
100 kHz	100%	OOK	-102.6	3	10	5	54.5	3	8.6	55.0	0	3	3	0	9	0	-47.6	DNBL
1 MHz	100%	OOK	-134.5	3	10	5	54.5	3	8.6	55.0	6	3	3	0	9	0	-85.5	NRQT
100 kHz	20%	OOK	-109.4	3	10	5	54.5	3	8.6	55.0	0	3	3	0	9	0	-54.4	DNBL
1 MHz	20%	OOK	-134.5	3	10	5	54.5	3	8.6	55.0	6	3	3	0	9	0	-85.5	NRQT
100 kHz	100%	50% Abs.	-100	3	10	5	54.5	3	8.6	55.0	0	3	3	0	9	0	-45.0	DNBL
1 MHz	100%	50% Abs.	-134.5	3	10	5	54.5	3	8.6	55.0	6	3	3	0	9	0	-85.5	NRQT
5 MHz	100%	50% Abs.	-137	3	10	5	54.5	3	8.6	55.0	6	3	3	0	9	0	-88.0	RQT
20 MHz	100%	50% Abs.	-138	3	10	5	54.5	3	8.6	55.0	6	3	3	0	9	0	-89.0	RQT
100 kHz	100%	2% Rel.	-100	3	10	5	54.5	3	8.6	55.0	0	3	3	0	9	0	-45.0	DNBL
1 MHz	100%	2% Rel.	-134.5	3	10	5	54.5	3	8.6	55.0	6	3	3	0	9	0	-85.5	NRQT
5 MHz	100%	2% Rel.	-136.5	3	10	5	54.5	3	8.6	55.0	6	3	3	0	9	0	-87.5	RQT
20 MHz	100%	2% Rel.	-136	3	10	5	54.5	3	8.6	55.0	6	3	3	0	9	0	-87.0	RQT
100 kHz	20%	50% Abs.	-107	3	10	5	54.5	3	8.6	55.0	0	3	3	0	9	0	-52.0	DNBL
1 MHz	20%	50% Abs.	-134.5	3	10	5	54.5	3	8.6	55.0	6	3	3	0	9	0	-85.5	NRQT
5 MHz	20%	50% Abs.	-134.5	3	10	5	54.5	3	8.6	55.0	6	3	3	0	9	0	-85.5	NRQT
20 MHz	20%	50% Abs.	-134.5	3	10	5	54.5	3	8.6	55.0	6	3	3	0	9	0	-85.5	NRQT
100 kHz	20%	2% Rel.	-107	3	10	5	54.5	3	8.6	55.0	0	3	3	0	9	0	-52.0	DNBL
1 MHz	20%	2% Rel.	-134.5	3	10	5	54.5	3	8.6	55.0	6	3	3	0	9	0	-85.5	NRQT
5 MHz	20%	2% Rel.	-134.5	3	10	5	54.5	3	8.6	55.0	6	3	3	0	9	0	-85.5	NRQT
20 MHz	20%	2% Rel.	-134.5	3	10	5	54.5	3	8.6	55.0	6	3	3	0	9	0	-85.5	NRQT

BL - Break-lock

RQT - Reacquisition Time

DNBL - Did not break lock at the maximum available UWB generator signal power

NRQT - Broadband Noise Reacquisition

**Operational Scenario: Navigation in Constricted Waterways GPS Receiver and Multiple UWB Device (Indoor Operation) (I)**

**GPS Receiver Architecture: C/A-code**

			<b>Imax</b> (dBW/MHz)	<b>Hgps</b> (m)	<b>Huw</b> b (m)	<b>Hsep</b> (m)	<b>Theta</b> (deg)	<b>Gr</b> (dBic)	<b>Dmin</b> (m)	<b>Lp</b> (dB)	<b>Lmult</b> (dB)	<b>Lallot</b> (dB)	<b>Lman</b> (dB)	<b>Laf</b> (dB)	<b>Lba</b> (dB)	<b>Lsm</b> (dB)	<b>UWB EIRP</b> (dBW/MHz)	<b>Single Entry GPS Receiver Criteria</b> RQT
<b>Broadband Noise</b>			-134.5	13.5	10	37.5	-5.3	0	37.7	67.9	6	3	3	0	9	0	-69.6	
<b>UWB PRF</b>	<b>UWB Gating</b>	<b>UWB Mod.</b>	<b>Imax</b> (dBW/MHz)	<b>Hgps</b> (m)	<b>Huw</b> b (m)	<b>Hsep</b> (m)	<b>Theta</b> (deg)	<b>Gr</b> (dBic)	<b>Dmin</b> (m)	<b>Lp</b> (dB)	<b>Lmult</b> (dB)	<b>Lallot</b> (dB)	<b>Lman</b> (dB)	<b>Laf</b> (dB)	<b>Lba</b> (dB)	<b>Lsm</b> (dB)	<b>UWB EIRP</b> (dBW)	
1 MHz	100%	None	-143.7	13.5	10	37.5	-5.3	0	37.7	67.9	0	3	3	0	9	0	-72.8	BL
5 MHz	100%	None	-145.5	13.5	10	37.5	-5.3	0	37.7	67.9	0	3	3	0	9	0	-74.6	BL
20 MHz	100%	None	-145	13.5	10	37.5	-5.3	0	37.7	67.9	0	3	3	0	9	0	-74.1	BL
5 MHz	20%	None	-145.2	13.5	10	37.5	-5.3	0	37.7	67.9	0	3	3	0	9	0	-74.3	BL
20 MHz	20%	None	-145.8	13.5	10	37.5	-5.3	0	37.7	67.9	0	3	3	0	9	0	-74.9	BL
5 MHz	100%	OOK	-144.5	13.5	10	37.5	-5.3	0	37.7	67.9	0	3	3	0	9	0	-73.6	BL
20 MHz	100%	OOK	-144.5	13.5	10	37.5	-5.3	0	37.7	67.9	0	3	3	0	9	0	-73.6	BL
5 MHz	20%	OOK	-144.2	13.5	10	37.5	-5.3	0	37.7	67.9	0	3	3	0	9	0	-73.3	BL
20 MHz	20%	OOK	-146.3	13.5	10	37.5	-5.3	0	37.7	67.9	0	3	3	0	9	0	-75.4	BL
<b>UWB PRF</b>	<b>UWB Gating</b>	<b>UWB Mod.</b>	<b>Imax</b> (dBW/MHz)	<b>Hgps</b> (m)	<b>Huw</b> b (m)	<b>Hsep</b> (m)	<b>Theta</b> (deg)	<b>Gr</b> (dBic)	<b>Dmin</b> (m)	<b>Lp</b> (dB)	<b>Lmult</b> (dB)	<b>Lallot</b> (dB)	<b>Lman</b> (dB)	<b>Laf</b> (dB)	<b>Lba</b> (dB)	<b>Lsm</b> (dB)	<b>UWB EIRP</b> (dBW/MHz)	<b>GPS Receiver Criteria</b>
100 kHz	100%	None	-112.6	13.5	10	37.5	-5.3	0	37.7	67.9	0	3	3	0	9	0	-41.7	BL
100 kHz	20%	None	-106.5	13.5	10	37.5	-5.3	0	37.7	67.9	0	3	3	0	9	0	-35.6	DNBL
1 MHz	20%	None	-134.5	13.5	10	37.5	-5.3	0	37.7	67.9	6	3	3	0	9	0	-69.6	NRQT
100 kHz	100%	OOK	-102.6	13.5	10	37.5	-5.3	0	37.7	67.9	0	3	3	0	9	0	-31.7	DNBL
1 MHz	100%	OOK	-134.5	13.5	10	37.5	-5.3	0	37.7	67.9	6	3	3	0	9	0	-69.6	NRQT
100 kHz	20%	OOK	-109.4	13.5	10	37.5	-5.3	0	37.7	67.9	0	3	3	0	9	0	-38.5	DNBL
1 MHz	20%	OOK	-134.5	13.5	10	37.5	-5.3	0	37.7	67.9	6	3	3	0	9	0	-69.6	NRQT
100 kHz	100%	50%	-100	13.5	10	37.5	-5.3	0	37.7	67.9	0	3	3	0	9	0	-29.1	DNBL
1 MHz	100%	50% Abs.	-134.5	13.5	10	37.5	-5.3	0	37.7	67.9	6	3	3	0	9	0	-69.6	NRQT
5 MHz	100%	50% Abs.	-137	13.5	10	37.5	-5.3	0	37.7	67.9	6	3	3	0	9	0	-72.1	RQT
20 MHz	100%	50% Abs.	-138	13.5	10	37.5	-5.3	0	37.7	67.9	6	3	3	0	9	0	-73.1	RQT
100 kHz	100%	2% Rel.	-100	13.5	10	37.5	-5.3	0	37.7	67.9	0	3	3	0	9	0	-29.1	DNBL
1 MHz	100%	2% Rel.	-134.5	13.5	10	37.5	-5.3	0	37.7	67.9	6	3	3	0	9	0	-69.6	NRQT
5 MHz	100%	2% Rel.	-136.5	13.5	10	37.5	-5.3	0	37.7	67.9	6	3	3	0	9	0	-71.6	RQT
20 MHz	100%	2% Rel.	-136	13.5	10	37.5	-5.3	0	37.7	67.9	6	3	3	0	9	0	-71.1	RQT
100 kHz	20%	50% Abs.	-107	13.5	10	37.5	-5.3	0	37.7	67.9	0	3	3	0	9	0	-36.1	DNBL
1 MHz	20%	50% Abs.	-134.5	13.5	10	37.5	-5.3	0	37.7	67.9	6	3	3	0	9	0	-69.6	NRQT
5 MHz	20%	50% Abs.	-134.5	13.5	10	37.5	-5.3	0	37.7	67.9	6	3	3	0	9	0	-69.6	NRQT
20 MHz	20%	50% Abs.	-134.5	13.5	10	37.5	-5.3	0	37.7	67.9	6	3	3	0	9	0	-69.6	NRQT
100 kHz	20%	2% Rel.	-107	13.5	10	37.5	-5.3	0	37.7	67.9	0	3	3	0	9	0	-36.1	DNBL
1 MHz	20%	2% Rel.	-134.5	13.5	10	37.5	-5.3	0	37.7	67.9	6	3	3	0	9	0	-69.6	NRQT
5 MHz	20%	2% Rel.	-134.5	13.5	10	37.5	-5.3	0	37.7	67.9	6	3	3	0	9	0	-69.6	NRQT
20 MHz	20%	2% Rel.	-134.5	13.5	10	37.5	-5.3	0	37.7	67.9	6	3	3	0	9	0	-69.6	NRQT

BL -Break-lock

RQT - Reacquisition Time

DNBL - Did not break lock at the maximum available

UWB generator signal power

NRQT - Broadband Noise Reacquisition

Operational Scenario: Navigation in Constricted Waterways GPS Receiver and Multiple UWB Device (Outdoor Operation) (I)

GPS Receiver Architecture: C/A-code

Broadband Noise			Imax (dBW/MHz)	Hgps (m)	Huw b (m)	Hsep (m)	Theta (deg)	Gr (dBic)	Dmin (m)	Lp (dB)	Lmul t (dB)	Lallot (dB)	Lman (dB)	Laf (dB)	Lba (dB)	Lsm (dB)	UWB EIRP (dBW/MHz)	GPS Receiver Criteria
UWB PRF	UWB Gating	UWB Mod.	Imax (dBW)	Hgps (m)	Huw b (m)	Hsep (m)	Theta (deg)	Gr (dBic)	Dmin (m)	Lp (dB)	Lmul t (dB)	Lallot (dB)	Lman (dB)	Laf (dB)	Lba (dB)	Lsm (dB)	UWB EIRP (dBW)	GPS Receiver Criteria
			-134.5	13.5	3	37.5	-15.6	-3	38.9	68.2	6	3	3	0	0	0	-75.3	RQT
1 MHz	100%	None	-143.7	13.5	3	37.5	-15.6	-3	38.9	68.2	0	3	3	0	0	0	-78.5	BL
5 MHz	100%	None	-145.5	13.5	3	37.5	-15.6	-3	38.9	68.2	0	3	3	0	0	0	-80.3	BL
20 MHz	100%	None	-145	13.5	3	37.5	-15.6	-3	38.9	68.2	0	3	3	0	0	0	-79.8	BL
5 MHz	20%	None	-145.2	13.5	3	37.5	-15.6	-3	38.9	68.2	0	3	3	0	0	0	-80.0	BL
20 MHz	20%	None	-145.8	13.5	3	37.5	-15.6	-3	38.9	68.2	0	3	3	0	0	0	-80.6	BL
5 MHz	100%	OOK	-144.5	13.5	3	37.5	-15.6	-3	38.9	68.2	0	3	3	0	0	0	-79.3	BL
20 MHz	100%	OOK	-144.5	13.5	3	37.5	-15.6	-3	38.9	68.2	0	3	3	0	0	0	-79.3	BL
5 MHz	20%	OOK	-144.2	13.5	3	37.5	-15.6	-3	38.9	68.2	0	3	3	0	0	0	-79.0	BL
20 MHz	20%	OOK	-146.3	13.5	3	37.5	-15.6	-3	38.9	68.2	0	3	3	0	0	0	-81.1	BL
UWB PRF	UWB Gating	UWB Mod.	Imax (dBW/MHz)	Hgps (m)	Huw b (m)	Hsep (m)	Theta (deg)	Gr (dBic)	Dmin (m)	Lp (dB)	Lmul t (dB)	Lallot (dB)	Lman (dB)	Laf (dB)	Lba (dB)	Lsm (dB)	UWB EIRP (dBW/MHz)	GPS Receiver Criteria
100 kHz	100%	None	-112.6	13.5	3	37.5	-15.6	-3	38.9	68.2	0	3	3	0	0	0	-47.4	BL
100 kHz	20%	None	-106.5	13.5	3	37.5	-15.6	-3	38.9	68.2	0	3	3	0	0	0	-41.3	DNBL
1 MHz	20%	None	-134.5	13.5	3	37.5	-15.6	-3	38.9	68.2	6	3	3	0	0	0	-75.3	NRQT
100 kHz	100%	OOK	-102.6	13.5	3	37.5	-15.6	-3	38.9	68.2	0	3	3	0	0	0	-37.4	DNBL
1 MHz	100%	OOK	-134.5	13.5	3	37.5	-15.6	-3	38.9	68.2	6	3	3	0	0	0	-75.3	NRQT
100 kHz	20%	OOK	-109.4	13.5	3	37.5	-15.6	-3	38.9	68.2	0	3	3	0	0	0	-44.2	DNBL
1 MHz	20%	OOK	-134.5	13.5	3	37.5	-15.6	-3	38.9	68.2	6	3	3	0	0	0	-75.3	NRQT
100 kHz	100%	50%	-100	13.5	3	37.5	-15.6	-3	38.9	68.2	0	3	3	0	0	0	-34.8	DNBL
		Abs.																
1 MHz	100%	50%	-134.5	13.5	3	37.5	-15.6	-3	38.9	68.2	6	3	3	0	0	0	-75.3	NRQT
		Abs.																
5 MHz	100%	50%	-137	13.5	3	37.5	-15.6	-3	38.9	68.2	6	3	3	0	0	0	-77.8	RQT
		Abs.																
20 MHz	100%	50%	-138	13.5	3	37.5	-15.6	-3	38.9	68.2	6	3	3	0	0	0	-78.8	RQT
		Abs.																
100 kHz	100%	2% Rel.	-100	13.5	3	37.5	-15.6	-3	38.9	68.2	0	3	3	0	0	0	-34.8	DNBL
1 MHz	100%	2% Rel.	-134.5	13.5	3	37.5	-15.6	-3	38.9	68.2	6	3	3	0	0	0	-75.3	NRQT
5 MHz	100%	2% Rel.	-136.5	13.5	3	37.5	-15.6	-3	38.9	68.2	6	3	3	0	0	0	-77.3	RQT
20 MHz	100%	2% Rel.	-136	13.5	3	37.5	-15.6	-3	38.9	68.2	6	3	3	0	0	0	-76.8	RQT
100 kHz	20%	50%	-107	13.5	3	37.5	-15.6	-3	38.9	68.2	0	3	3	0	0	0	-41.8	DNBL
		Abs.																
1 MHz	20%	50%	-13.5	13.5	3	37.5	-15.6	-3	38.9	68.2	6	3	3	0	0	0	-75.3	NRQT
		Abs.																
5 MHz	20%	50%	-134.5	13.5	3	37.5	-15.6	-3	38.9	68.2	6	3	3	0	0	0	-75.3	NRQT
		Abs.																
20 MHz	20%	50%	-134.5	13.5	3	37.5	-15.6	-3	38.9	68.2	6	3	3	0	0	0	-75.3	NRQT
		Abs.																
100 kHz	20%	2% Rel.	-107	13.5	3	37.5	-15.6	-3	38.9	68.2	0	3	3	0	0	0	-41.8	DNBL
1 MHz	20%	2% Rel.	-134.5	13.5	3	37.5	-15.6	-3	38.9	68.2	6	3	3	0	0	0	-75.3	NRQT
5 MHz	20%	2% Rel.	-134.5	13.5	3	37.5	-15.6	-3	38.9	68.2	6	3	3	0	0	0	-75.3	NRQT
20 MHz	20%	2% Rel.	-134.5	13.5	3	37.5	-15.6	-3	38.9	68.2	6	3	3	0	0	0	-75.3	NRQT

BL - Break-lock

RQT - Reacquisition Time

DNBL - Did not break lock at the maximum

UWB generator signal power

NRQT - Broadband Noise Reacquisition

**Operational Scenario: Navigation in Constricted Waterways GPS Receiver and Multiple UWB Device (Indoor Operation) (II)**  
**GPS Receiver Architecture: C/A-code**

			I <sub>max</sub>	H <sub>gps</sub>	H <sub>uw</sub>	H <sub>sep</sub>	Theta	Gr	D <sub>min</sub>	L <sub>p</sub>	L <sub>mult</sub>	L <sub>allot</sub>	L <sub>man</sub>	L <sub>af</sub>	L <sub>ba</sub>	L <sub>sm</sub>	UWB EIRP	GPS Receiver
			(dBW/MHz)	(m)	b (m)	(m)	(deg)	(dBic)	(m)	(dB)	(dB)	(dB)	(dB)	(dB)	(dB)	(dB)	(dBW/MHz)	Criteria
<b>Broadband Noise</b>			-134.5	7.5	10	51	2.8	0	51.1	70.5	6	3	3	0	9	0	-67.0	RQT
UWB PRF	UWB Gating	UWB Mod.	I <sub>max</sub>	H <sub>gps</sub>	H <sub>uw</sub>	H <sub>sep</sub>	Theta	Gr	D <sub>min</sub>	L <sub>p</sub>	L <sub>mult</sub>	L <sub>allot</sub>	L <sub>man</sub>	L <sub>af</sub>	L <sub>ba</sub>	L <sub>sm</sub>	UWB EIRP	GPS Receiver
			(dBW)	(m)	b (m)	(m)	(deg)	(dBic)	(m)	(dB)	(dB)	(dB)	(dB)	(dB)	(dB)	(dB)	(dBW)	Criteria
1 MHz	100%	None	-143.7	7.5	10	51	2.8	0	51.1	70.5	0	3	3	0	9	0	-70.2	BL
5 MHz	100%	None	-145.5	7.5	10	51	2.8	0	51.1	70.5	0	3	3	0	9	0	-72.0	BL
20 MHz	100%	None	-145	7.5	10	51	2.8	0	51.1	70.5	0	3	3	0	9	0	-71.5	BL
5 MHz	20%	None	-145.2	7.5	10	51	2.8	0	51.1	70.5	0	3	3	0	9	0	-71.7	BL
20 MHz	20%	None	-145.8	7.5	10	51	2.8	0	51.1	70.5	0	3	3	0	9	0	-72.3	BL
5 MHz	100%	OOK	-144.5	7.5	10	51	2.8	0	51.1	70.5	0	3	3	0	9	0	-71.0	BL
20 MHz	100%	OOK	-144.5	7.5	10	51	2.8	0	51.1	70.5	0	3	3	0	9	0	-71.0	BL
5 MHz	20%	OOK	-144.2	7.5	10	51	2.8	0	51.1	70.5	0	3	3	0	9	0	-70.7	BL
20 MHz	20%	OOK	-146.3	7.5	10	51	2.8	0	51.1	70.5	0	3	3	0	9	0	-72.8	BL
UWB PRF	UWB Gating	UWB Mod.	I <sub>max</sub>	H <sub>gps</sub>	H <sub>uw</sub>	H <sub>sep</sub>	Theta	Gr	D <sub>min</sub>	L <sub>p</sub>	L <sub>mult</sub>	L <sub>allot</sub>	L <sub>man</sub>	L <sub>af</sub>	L <sub>ba</sub>	L <sub>sm</sub>	UWB EIRP	GPS Receiver
			(dBW/MHz)	(m)	b (m)	(m)	(deg)	(dBic)	(m)	(dB)	(dB)	(dB)	(dB)	(dB)	(dB)	(dB)	(dBW/MHz)	Criteria
100 kHz	100%	None	-112.6	7.5	10	51	2.8	0	51.1	70.5	0	3	3	0	9	0	-39.1	BL
100 kHz	20%	None	-106.5	7.5	10	51	2.8	0	51.1	70.5	0	3	3	0	9	0	-33.0	DNBL
1 MHz	20%	None	-134.5	7.5	10	51	2.8	0	51.1	70.5	6	3	3	0	9	0	-67.0	NRQT
100 kHz	100%	OOK	-102.6	7.5	10	51	2.8	0	51.1	70.5	0	3	3	0	9	0	-29.1	DNBL
1 MHz	100%	OOK	-134.5	7.5	10	51	2.8	0	51.1	70.5	6	3	3	0	9	0	-67.0	NRQT
100 kHz	20%	OOK	-109.4	7.5	10	51	2.8	0	51.1	70.5	0	3	3	0	9	0	-35.9	DNBL
1 MHz	20%	OOK	-134.5	7.5	10	51	2.8	0	51.1	70.5	6	3	3	0	9	0	-67.0	NRQT
100 kHz	100%	50% Abs.	-100	7.5	10	51	2.8	0	51.1	70.5	0	3	3	0	9	0	-26.5	DNBL
1 MHz	100%	50% Abs.	-134.5	7.5	10	51	2.8	0	51.1	70.5	6	3	3	0	9	0	-67.0	NRQT
5 MHz	100%	50% Abs.	-137	7.5	10	51	2.8	0	51.1	70.5	6	3	3	0	9	0	-69.5	RQT
20 MHz	100%	50% Abs.	-138	7.5	10	51	2.8	0	51.1	70.5	6	3	3	0	9	0	-70.5	RQT
100 kHz	100%	2% Rel.	-100	7.5	10	51	2.8	0	51.1	70.5	0	3	3	0	9	0	-26.5	DNBL
1 MHz	100%	2% Rel.	-134.5	7.5	10	51	2.8	0	51.1	70.5	6	3	3	0	9	0	-67.0	NRQT
5 MHz	100%	2% Rel.	-136.5	7.5	10	51	2.8	0	51.1	70.5	6	3	3	0	9	0	-69.0	RQT
20 MHz	100%	2% Rel.	-136	7.5	10	51	2.8	0	51.1	70.5	6	3	3	0	9	0	-68.5	RQT
100 kHz	20%	50% Abs.	-107	7.5	10	51	2.8	0	51.1	70.5	0	3	3	0	9	0	-33.5	DNBL
1 MHz	20%	50% Abs.	-134.5	7.5	10	51	2.8	0	51.1	70.5	6	3	3	0	9	0	-67.0	NRQT
5 MHz	20%	50% Abs.	-134.5	7.5	10	51	2.8	0	51.1	70.5	6	3	3	0	9	0	-67.0	NRQT
20 MHz	20%	50% Abs.	-134.5	7.5	10	51	2.8	0	51.1	70.5	6	3	3	0	9	0	-67.0	NRQT
100 kHz	20%	2% Rel.	-107	7.5	10	51	2.8	0	51.1	70.5	0	3	3	0	9	0	-33.5	DNBL
1 MHz	20%	2% Rel.	-134.5	7.5	10	51	2.8	0	51.1	70.5	6	3	3	0	9	0	-67.0	NRQT
5 MHz	20%	2% Rel.	-134.5	7.5	10	51	2.8	0	51.1	70.5	6	3	3	0	9	0	-67.0	NRQT
20 MHz	20%	2% Rel.	-134.5	7.5	10	51	2.8	0	51.1	70.5	6	3	3	0	9	0	-67.0	NRQT

BL - Break-lock

RQT - Reacquisition Time

DNBL - Did not break lock at the maximum available UWB generator signal power

NRQT - Broadband Noise Reacquisition

**Operational Scenario: Navigation in Constricted Waterways GPS Receiver and Multiple UWB Device (Outdoor Operation) (II)**

**GPS Receiver Architecture: C/A-code**

			I <sub>max</sub> (dBW/MHz)	H <sub>gps</sub> (m)	H <sub>uw</sub> b (m)	H <sub>sep</sub> (m)	Theta (deg)	Gr (dBic)	D <sub>min</sub> (m)	L <sub>p</sub> (dB)	L <sub>mult</sub> (dB)	L <sub>allot</sub> (dB)	L <sub>man</sub> (dB)	L <sub>af</sub> (dB)	L <sub>ba</sub> (dB)	L <sub>sm</sub> (dB)	UWB EIRP (dBW/MHz)	GPS Receiver Criteria
<b>Broadband Noise</b>			-134.5	7.5	3	51	-5.0	0	51.2	70.5	6	3	3	0	0	0	-76.0	RQT
UWB PRF	UWB Gating	UWB Mod.	I <sub>max</sub> (dBW)	H <sub>gps</sub> (m)	H <sub>uw</sub> b (m)	H <sub>sep</sub> (m)	Theta (deg)	Gr (dBic)	D <sub>min</sub> (m)	L <sub>p</sub> (dB)	L <sub>mult</sub> (dB)	L <sub>allot</sub> (dB)	L <sub>man</sub> (dB)	L <sub>af</sub> (dB)	L <sub>ba</sub> (dB)	L <sub>sm</sub> (dB)	UWB EIRP (dBW)	GPS Receiver Criteria
1 MHz	100%	None	-143.7	7.5	3	51	-5.0	0	51.2	70.5	0	3	3	0	0	0	-79.2	BL
5 MHz	100%	None	-145.5	7.5	3	51	-5.0	0	51.2	70.5	0	3	3	0	0	0	-81.0	BL
20 MHz	100%	None	-145	7.5	3	51	-5.0	0	51.2	70.5	0	3	3	0	0	0	-80.5	BL
5 MHz	20%	None	-145.2	7.5	3	51	-5.0	0	51.2	70.5	0	3	3	0	0	0	-80.7	BL
20 MHz	20%	None	-145.8	7.5	3	51	-5.0	0	51.2	70.5	0	3	3	0	0	0	-81.3	BL
5 MHz	100%	OOK	-144.5	7.5	3	51	-5.0	0	51.2	70.5	0	3	3	0	0	0	-80.0	BL
20 MHz	100%	OOK	-144.5	7.5	3	51	-5.0	0	51.2	70.5	0	3	3	0	0	0	-80.0	BL
5 MHz	20%	OOK	-144.2	7.5	3	51	-5.0	0	51.2	70.5	0	3	3	0	0	0	-79.7	BL
20 MHz	20%	OOK	-146.3	7.5	3	51	-5.0	0	51.2	70.5	0	3	3	0	0	0	-81.8	BL
UWB PRF	UWB Gating	UWB Mod.	I <sub>max</sub> (dBW/MHz)	H <sub>gps</sub> (m)	H <sub>uw</sub> b (m)	H <sub>sep</sub> (m)	Theta (deg)	Gr (dBic)	D <sub>min</sub> (m)	L <sub>p</sub> (dB)	L <sub>mult</sub> (dB)	L <sub>allot</sub> (dB)	L <sub>man</sub> (dB)	L <sub>af</sub> (dB)	L <sub>ba</sub> (dB)	L <sub>sm</sub> (dB)	UWB EIRP (dBW/MHz)	GPS Receiver Criteria
100 kHz	100%	None	-112.6	7.5	3	51	-5.0	0	51.2	70.5	0	3	3	0	0	0	-48.1	BL
100 kHz	20%	None	-106.5	7.5	3	51	-5.0	0	51.2	70.5	0	3	3	0	0	0	-42.0	DNBL
1 MHz	20%	None	-134.5	7.5	3	51	-5.0	0	51.2	70.5	6	3	3	0	0	0	-76.0	NRQT
100 kHz	100%	OOK	-102.6	7.5	3	51	-5.0	0	51.2	70.5	0	3	3	0	0	0	-38.1	DNBL
1 MHz	100%	OOK	-134.5	7.5	3	51	-5.0	0	51.2	70.5	6	3	3	0	0	0	-76.0	NRQT
100 kHz	20%	OOK	-109.4	7.5	3	51	-5.0	0	51.2	70.5	0	3	3	0	0	0	-44.9	DNBL
1 MHz	20%	OOK	-134.5	7.5	3	51	-5.0	0	51.2	70.5	6	3	3	0	0	0	-76.0	NRQT
100 kHz	100%	50% Abs.	-100	7.5	3	51	-5.0	0	51.2	70.5	0	3	3	0	0	0	-35.5	DNBL
1 MHz	100%	50% Abs.	-134.5	7.5	3	51	-5.0	0	51.2	70.5	6	3	3	0	0	0	-76.0	NRQT
5 MHz	100%	50% Abs.	-137	7.5	3	51	-5.0	0	51.2	70.5	6	3	3	0	0	0	-78.5	RQT
20 MHz	100%	50% Abs.	-138	7.5	3	51	-5.0	0	51.2	70.5	6	3	3	0	0	0	-79.5	RQT
100 kHz	100%	2% Rel.	-100	7.5	3	51	-5.0	0	51.2	70.5	0	3	3	0	0	0	-35.5	DNBL
1 MHz	100%	2% Rel.	-134.5	7.5	3	51	-5.0	0	51.2	70.5	6	3	3	0	0	0	-76.0	NRQT
5 MHz	100%	2% Rel.	-136.5	7.5	3	51	-5.0	0	51.2	70.5	6	3	3	0	0	0	-78.0	RQT
20 MHz	100%	2% Rel.	-136	7.5	3	51	-5.0	0	51.2	70.5	6	3	3	0	0	0	-77.5	RQT
100 kHz	20%	50% Abs.	-107	7.5	3	51	-5.0	0	51.2	70.5	0	3	3	0	0	0	-42.5	DNBL
1 MHz	20%	50% Abs.	-134.5	7.5	3	51	-5.0	0	51.2	70.5	6	3	3	0	0	0	-76.0	NRQT
5 MHz	20%	50% Abs.	-134.5	7.5	3	51	-5.0	0	51.2	70.5	6	3	3	0	0	0	-76.0	NRQT
20 MHz	20%	50% Abs.	-134.5	7.5	3	51	-5.0	0	51.2	70.5	6	3	3	0	0	0	-76.0	NRQT
100 kHz	20%	2% Rel.	-107	7.5	3	51	-5.0	0	51.2	70.5	0	3	3	0	0	0	-42.5	DNBL
1 MHz	20%	2% Rel.	-134.5	7.5	3	51	-5.0	0	51.2	70.5	6	3	3	0	0	0	-76.0	NRQT
5 MHz	20%	2% Rel.	-134.5	7.5	3	51	-5.0	0	51.2	70.5	6	3	3	0	0	0	-76.0	NRQT
20 MHz	20%	2% Rel.	-134.5	7.5	3	51	-5.0	0	51.2	70.5	6	3	3	0	0	0	-76.0	NRQT

BL - Break-lock

RQT - Reacquisition Time

DNBL - Did not break lock at the maximum

UWB generator signal power

NRQT - Broadband Noise Reacquisition

**Operational Scenario: Railway GPS Receiver and Multiple UWB Device (Outdoor Operation)**

**GPS Receiver Architecture: C/A-code**

			I <sub>max</sub> (dBW/MHz)	H <sub>gps</sub> (m)	H <sub>w</sub> b (m)	H <sub>sep</sub> (m)	Theta (deg)	Gr (dBic)	D <sub>min</sub> (m)	L <sub>p</sub> (dB)	L <sub>mult</sub> (dB)	L <sub>allot</sub> (dB)	L <sub>man</sub> (dB)	L <sub>af</sub> (dB)	L <sub>ba</sub> (dB)	L <sub>sm</sub> (dB)	UWB EIRP (dBW/MHz)	GPS Receiver Criteria
<b>B r o a d b a n d Noise</b>			-134.5	10	3	7	-45	-4.5	9.9	56.3	4.8	3	3	0	0	0	-84.5	RQT
UWB PRF	UWB Gating	UWB Mod.	I <sub>max</sub> (dBW)	H <sub>gps</sub> (m)	H <sub>w</sub> b (m)	H <sub>sep</sub> (m)	Theta (deg)	Gr (dBic)	D <sub>min</sub> (m)	L <sub>p</sub> (dB)	L <sub>mult</sub> (dB)	L <sub>allot</sub> (dB)	L <sub>man</sub> (dB)	L <sub>af</sub> (dB)	L <sub>ba</sub> (dB)	L <sub>sm</sub> (dB)	UWB EIRP (dBW)	GPS Receiver Criteria
1 MHz	100%	None	-143.7	10	3	7	-45	-4.5	9.9	56.3	0	3	3	0	0	0	-88.9	BL
5 MHz	100%	None	-145.5	10	3	7	-45	-4.5	9.9	56.3	0	3	3	0	0	0	-90.7	BL
20 MHz	100%	None	-145	10	3	7	-45	-4.5	9.9	56.3	0	3	3	0	0	0	-90.2	BL
5 MHz	20%	None	-145.2	10	3	7	-45	-4.5	9.9	56.3	0	3	3	0	0	0	-90.4	BL
20 MHz	20%	None	-145.8	10	3	7	-45	-4.5	9.9	56.3	0	3	3	0	0	0	-91.0	BL
5 MHz	100%	OOK	-144.5	10	3	7	-45	-4.5	9.9	56.3	0	3	3	0	0	0	-89.7	BL
20 MHz	100%	OOK	-144.5	10	3	7	-45	-4.5	9.9	56.3	0	3	3	0	0	0	-89.7	BL
5 MHz	20%	OOK	-144.2	10	3	7	-45	-4.5	9.9	56.3	0	3	3	0	0	0	-89.4	BL
20 MHz	20%	OOK	-146.3	10	3	7	-45	-4.5	9.9	56.3	0	3	3	0	0	0	-91.5	BL
100 kHz	100%	None	-112.6	10	3	7	-45	-4.5	9.9	56.3	0	3	3	0	0	0	-57.8	BL
100 kHz	20%	None	-106.5	10	3	7	-45	-4.5	9.9	56.3	0	3	3	0	0	0	-51.7	DNBL
1 MHz	20%	None	-134.5	10	3	7	-45	-4.5	9.9	56.3	4.8	3	3	0	0	0	-84.5	NRQT
100 kHz	100%	OOK	-102.6	10	3	7	-45	-4.5	9.9	56.3	0	3	3	0	0	0	-47.8	DNBL
1 MHz	100%	OOK	-134.5	10	3	7	-45	-4.5	9.9	56.3	4.8	3	3	0	0	0	-84.5	NRQT
100 kHz	20%	OOK	-109.4	10	3	7	-45	-4.5	9.9	56.3	0	3	3	0	0	0	-54.6	DNBL
1 MHz	20%	OOK	-134.5	10	3	7	-45	-4.5	9.9	56.3	4.8	3	3	0	0	0	-84.5	NRQT
100 kHz	100%	50% Abs.	-100	10	3	7	-45	-4.5	9.9	56.3	0	3	3	0	0	0	-45.2	DNBL
1 MHz	100%	50% Abs.	-134.5	10	3	7	-45	-4.5	9.9	56.3	4.8	3	3	0	0	0	-84.5	NRQT
5 MHz	100%	50% Abs.	-137	10	3	7	-45	-4.5	9.9	56.3	4.8	3	3	0	0	0	-87	RQT
20 MHz	100%	50% Abs.	-138	10	3	7	-45	-4.5	9.9	56.3	4.8	3	3	0	0	0	-88	RQT
100 kHz	100%	2% Rel.	-100	10	3	7	-45	-4.5	9.9	56.3	0	3	3	0	0	0	-45.2	DNBL
1 MHz	100%	2% Rel.	-134.5	10	3	7	-45	-4.5	9.9	56.3	4.8	3	3	0	0	0	-84.5	NRQT
5 MHz	100%	2% Rel.	-136.5	10	3	7	-45	-4.5	9.9	56.3	4.8	3	3	0	0	0	-86.5	RQT
20 MHz	100%	2% Rel.	-136	10	3	7	-45	-4.5	9.9	56.3	4.8	3	3	0	0	0	-86	RQT
100 kHz	20%	50% Abs.	-107	10	3	7	-45	-4.5	9.9	56.3	0	3	3	0	0	0	-52.2	DNBL
1 MHz	20%	50% Abs.	-134.5	10	3	7	-45	-4.5	9.9	56.3	4.8	3	3	0	0	0	-84.5	NRQT
5 MHz	20%	50% Abs.	-134.5	10	3	7	-45	-4.5	9.9	56.3	4.8	3	3	0	0	0	-84.5	NRQT
20 MHz	20%	50% Abs.	-134.5	10	3	7	-45	-4.5	9.9	56.3	4.8	3	3	0	0	0	-84.5	NRQT
100 kHz	20%	2% Rel.	-107	10	3	7	-45	-4.5	9.9	56.3	0	3	3	0	0	0	-52.2	DNBL
1 MHz	20%	2% Rel.	-134.5	10	3	7	-45	-4.5	9.9	56.3	4.8	3	3	0	0	0	-84.5	NRQT
5 MHz	20%	2% Rel.	-134.5	10	3	7	-45	-4.5	9.9	56.3	4.8	3	3	0	0	0	-84.5	NRQT
20 MHz	20%	2% Rel.	-134.5	10	3	7	-45	-4.5	9.9	56.3	4.8	3	3	0	0	0	-84.5	NRQT

BL - Break-lock

RQT - Reacquisition Time

DNBL - Did not break lock at the maximum UWB generator signal power

NRQT - Broadband Noise Reacquisition



**Operational Scenario: Railway GPS Receiver and Multiple UWB Device (Indoor Operation)**  
**GPS Receiver Architecture: C/A-code**

			Imax (dBW/MHz)	Hgps (m)	Huw b (m)	Hsep (m)	Theta (deg)	Gr (dBic)	Dmin (m)	Lp (dB)	Lmult (dB)	Lallot (dB)	Lman (dB)	Laf (dB)	Lba (dB)	Lsm (dB)	UWB EIRP (dBW/MHz)	GPS Receiver Criteria
<b>B r o a d b a n d N o i s e</b>			-134.5	10	10	7	0.0	0	7.0	53.3	4.8	3	3	0	9	0	-83.0	RQT
UWB PRF	UWB Gating	UWB Mod.	Imax (dBW)	Hgps (m)	Huw b (m)	Hsep (m)	Theta (deg)	Gr (dBic)	Dmin (m)	Lp (dB)	Lmult (dB)	Lallot (dB)	Lman (dB)	Laf (dB)	Lba (dB)	Lsm (dB)	UWB EIRP (dBW)	GPS Receiver Criteria
1 MHz	100%	None	-143.7	10	10	7	0.0	0	7.0	53.3	0	3	3	0	9	0	-87.4	BL
5 MHz	100%	None	-145.5	10	10	7	0.0	0	7.0	53.3	0	3	3	0	9	0	-89.2	BL
20 MHz	100%	None	-145	10	10	7	0.0	0	7.0	53.3	0	3	3	0	9	0	-88.7	BL
5 MHz	20%	None	-145.2	10	10	7	0.0	0	7.0	53.3	0	3	3	0	9	0	-88.9	BL
20 MHz	20%	None	-145.8	10	10	7	0.0	0	7.0	53.3	0	3	3	0	9	0	-89.5	BL
5 MHz	100%	OOK	-144.5	10	10	7	0.0	0	7.0	53.3	0	3	3	0	9	0	-88.2	BL
20 MHz	100%	OOK	-144.5	10	10	7	0.0	0	7.0	53.3	0	3	3	0	9	0	-88.2	BL
5 MHz	20%	OOK	-144.2	10	10	7	0.0	0	7.0	53.3	0	3	3	0	9	0	-87.9	BL
20 MHz	20%	OOK	-146.3	10	10	7	0.0	0	7.0	53.3	0	3	3	0	9	0	-90.0	BL
UWB PRF	UWB Gating	UWB Mod.	Imax (dBW/MHz)	Hgps (m)	Huw b (m)	Hsep (m)	Theta (deg)	Gr (dBic)	Dmin (m)	Lp (dB)	Lmult (dB)	Lallot (dB)	Lman (dB)	Laf (dB)	Lba (dB)	Lsm (dB)	UWB EIRP (dBW/MHz)	GPS Receiver Criteria
100 kHz	100%	None	-112.6	10	10	7	0.0	0	7.0	53.3	0	3	3	0	9	0	-56.3	BL
100 kHz	20%	None	-106.5	10	10	7	0.0	0	7.0	53.3	0	3	3	0	9	0	-50.2	DNBL
1 MHz	20%	None	-134.5	10	10	7	0.0	0	7.0	53.3	4.8	3	3	0	9	0	-83	NRQT
100 kHz	100%	OOK	-102.6	10	10	7	0.0	0	7.0	53.3	0	3	3	0	9	0	-46.3	DNBL
1 MHz	100%	OOK	-134.5	10	10	7	0.0	0	7.0	53.3	4.8	3	3	0	9	0	-83	NRQT
100 kHz	20%	OOK	-109.4	10	10	7	0.0	0	7.0	53.3	0	3	3	0	9	0	-53.1	DNBL
1 MHz	20%	OOK	-134.5	10	10	7	0.0	0	7.0	53.3	4.8	3	3	0	9	0	-83	NRQT
100 kHz	100%	50% Abs.	-100	10	10	7	0.0	0	7.0	53.3	0	3	3	0	9	0	-43.7	DNBL
1 MHz	100%	50% Abs.	-134.5	10	10	7	0.0	0	7.0	53.3	4.8	3	3	0	9	0	-83	NRQT
5 MHz	100%	50% Abs.	-137	10	10	7	0.0	0	7.0	53.3	4.8	3	3	0	9	0	-85.5	RQT
20 MHz	100%	50% Abs.	-138	10	10	7	0.0	0	7.0	53.3	4.8	3	3	0	9	0	-86.5	RQT
100 kHz	100%	2% Rel.	-100	10	10	7	0.0	0	7.0	53.3	0	3	3	0	9	0	-43.7	DNBL
1 MHz	100%	2% Rel.	-134.5	10	10	7	0.0	0	7.0	53.3	4.8	3	3	0	9	0	-83	NRQT
5 MHz	100%	2% Rel.	-136.5	10	10	7	0.0	0	7.0	53.3	4.8	3	3	0	9	0	-85	RQT
20 MHz	100%	2% Rel.	-136	10	10	7	0.0	0	7.0	53.3	4.8	3	3	0	9	0	-84.5	RQT
100 kHz	20%	50% Abs.	-107	10	10	7	0.0	0	7.0	53.3	0	3	3	0	9	0	-50.7	DNBL
1 MHz	20%	50% Abs.	-134.5	10	10	7	0.0	0	7.0	53.3	4.8	3	3	0	9	0	-83	NRQT
5 MHz	20%	50% Abs.	-134.5	10	10	7	0.0	0	7.0	53.3	4.8	3	3	0	9	0	-83	NRQT
20 MHz	20%	50% Abs.	-134.5	10	10	7	0.0	0	7.0	53.3	4.8	3	3	0	9	0	-83	NRQT
100 kHz	20%	2% Rel.	-107	10	10	7	0.0	0	7.0	53.3	0	3	3	0	9	0	-50.7	DNBL
1 MHz	20%	2% Rel.	-134.5	10	10	7	0.0	0	7.0	53.3	4.8	3	3	0	9	0	-83	NRQT
5 MHz	20%	2% Rel.	-134.5	10	10	7	0.0	0	7.0	53.3	4.8	3	3	0	9	0	-83	NRQT
20 MHz	20%	2% Rel.	-134.5	10	10	7	0.0	0	7.0	53.3	4.8	3	3	0	9	0	-83	NRQT

BL - Break-lock

RQT - Reacquisition Time

DNBL - Did not break lock at the maximum UWB generator signal power

NRQT - Broadband Noise Reacquisition

**Operational Scenario: Surveying GPS Receiver and Single UWB Device**  
**GPS Receiver Architecture: Semi-Codeless**

Broadband Noise			I <sub>max</sub> (dBW/MHz)	H <sub>gps</sub> (m)	H <sub>uwb</sub> (m)	H <sub>sep</sub> (m)	Theta (deg)	Gr (dBic)	D <sub>min</sub> (m)	L <sub>p</sub> (dB)	L <sub>mult</sub> (dB)	L <sub>allot</sub> (dB)	L <sub>man</sub> (dB)	L <sub>af</sub> (dB)	L <sub>ba</sub> (dB)	L <sub>sm</sub> (dB)	UWB EIRP (dBW/MHz)	GPS Receiver Criteria
			-150	3	10	30	13.1	3	30.0	65.9	0	3	3	0	0	0	-93.1	RQT
UWB PRF	UWB Gating	UWB Mod.	I <sub>max</sub> (dBW/MHz)															
100 kHz	100%	None	-118.00	3	10	30	13.1	3	30.0	65.9	0	3	3	0	0	0	-61.1	RQT
20 MHz	100%	None	-145.00	3	10	30	13.1	3	30.0	65.9	0	3	3	0	0	0	-88.1	BL
100 kHz	100%	50% Abs.	-121	3	10	30	13.1	3	30.0	65.9	0	3	3	0	0	0	-64.1	RQT
1 MHz	100%	50% Abs.	-151	3	10	30	13.1	3	30.0	65.9	0	3	3	0	0	0	-94.1	RQR
5 MHz	100%	50% Abs.	-151	3	10	30	13.1	3	30.0	65.9	0	3	3	0	0	0	-94.1	RQT
20 MHz	100%	50% Abs.	-149.5	3	10	30	13.1	3	30.0	65.9	0	3	3	0	0	0	-92.6	RQT
100 kHz	100%	OOK	-112	3	10	30	13.1	3	30.0	65.9	0	3	3	0	0	0	-55.1	DNBL
20 MHz	100%	OOK	-137	3	10	30	13.1	3	30.0	65.9	0	3	3	0	0	0	-80.1	BL
100 kHz	100%	2% Rel.	-119	3	10	30	13.1	3	30.0	65.9	0	3	3	0	0	0	-62.1	RQT
1 MHz	100%	2% Rel.	-149	3	10	30	13.1	3	30.0	65.9	0	3	3	0	0	0	-92.1	RQT
5 MHz	100%	2% Rel.	-149	3	10	30	13.1	3	30.0	65.9	0	3	3	0	0	0	-92.1	RQT
20 MHz	100%	2% Rel.	-149.5	3	10	30	13.1	3	30.0	65.9	0	3	3	0	0	0	-92.6	RQT
100 kHz	20%	None	-116.5	3	10	30	13.1	3	30.0	65.9	0	3	3	0	0	0	-59.6	DNBL
20 MHz	20%	None	-148	3	10	30	13.1	3	30.0	65.9	0	3	3	0	0	0	-91.1	BL
100 kHz	20%	50% Abs.	-116	3	10	30	13.1	3	30.0	65.9	0	3	3	0	0	0	-59.1	DNBL
1 MHz	20%	50% Abs.	-132	3	10	30	13.1	3	30.0	65.9	0	3	3	0	0	0	-75.1	RQT
5 MHz	20%	50% Abs.	-151	3	10	30	13.1	3	30.0	65.9	0	3	3	0	0	0	-94.1	RQT
20 MHz	20%	50% Abs.	-148	3	10	30	13.1	3	30.0	65.9	0	3	3	0	0	0	-91.1	RQT
100 kHz	20%	OOK	-118.5	3	10	30	13.1	3	30.0	65.9	0	3	3	0	0	0	-61.6	DNBL
20 MHz	20%	OOK	-146	3	10	30	13.1	3	30.0	65.9	0	3	3	0	0	0	-89.1	BL
100 kHz	20%	2% Rel.	-138	3	10	30	13.1	3	30.0	65.9	0	3	3	0	0	0	-81.1	RQT
1 MHz	20%	2% Rel.	-134	3	10	30	13.1	3	30.0	65.9	0	3	3	0	0	0	-77.1	RQT
5 MHz	20%	2% Rel.	-142.5	3	10	30	13.1	3	30.0	65.9	0	3	3	0	0	0	-85.6	RQT
20 MHz	20%	2% Rel.	-143.5	3	10	30	13.1	3	30.0	65.9	0	3	3	0	0	0	-86.6	RQT

BL - Break-lock

RQT - Reacquisition Time

DNBL - Did not break lock at the maximum UWB generator signal power

Operational Scenario: Surveying GPS Receiver and Multiple UWB Devices

GPS Receiver Architecture: Semi-Codeless

Broadband Noise			Imax (dBW/MHz)	Hgps (m)	Huw b (m)	Hsep #1 (m)	Theta #1 (deg)	Gr #1 (dBic)	Dmin #1 (m)	Lp #1 (dB)	Hsep #2 (m)	Theta #2 (deg)	Gr #2 (dBic)	Dmin #2 (m)	Lp #2 (dB)	Hsep #3 (m)	Theta #3 (deg)	Gr #3 (dBic)	Dmin #3 (m)	Lp #3 (dB)	Lpa g (dB)	Lall ot (dB)	Lma n (dB)	Laf (dB)	Lba (dB)	Lsm (dB)	UWB EIRP (dBW/MHz)	GPS Receive Criteria
Broadband Noise			-150.00	3	10	30	13.1	3	30.0	65.9	300.0	1.3	0	300.0	85.9	750	0.5	0	750	93.8	65.8	3.00	3	0	0	0	-93.2	RQT
UWB PRF	UWB Gating	UWB Modulation	Imax (dBW/MHz)	Hgps (m)	Huw b (m)	Vsep #1 (m)	Theta #1 (deg)	Gr #1 (dBic)	Dmin #1 (m)	Lp #1 (dB)	Vsep #2 (m)	Theta #2 (deg)	Gr #2 (dBic)	Dmin #2 (m)	Lp #2 (dB)	Vsep #3 (m)	Theta #3 (deg)	Gr #3 (dBic)	Dmin #3 (m)	Lp #3 (dB)	Lpa gg (dB)	Lall ot (dB)	Lma n (dB)	Laf (dB)	Lba (dB)	Lsm (dB)	UWB EIRP (dBW/MHz)	GPS Receive Criteria
100 kHz	100%	None	-118.00	3	10	30	13.1	3	30.0	65.9	300.0	1.3	0	300.0	85.9	750	0.5	0	750	93.8	65.8	3.00	3	0	0	0	-61.2	RQT
20 MHz	100%	None	-145.00	3	10	30	13.1	3	30.0	65.9	300.0	1.3	0	300.0	85.9	750	0.5	0	750	93.8	65.8	3.00	3	0	0	0	-88.2	BL
100 kHz	100%	50% Abs.	-121	3	10	30	13.1	3	30.0	65.9	300.0	1.3	0	300.0	85.9	750	0.5	0	750	93.8	65.8	3.00	3	0	0	0	-64.2	RQT
1 MHz	100%	50% Abs.	-151	3	10	30	13.1	3	30.0	65.9	300.0	1.3	0	300.0	85.9	750	0.5	0	750	93.8	65.8	3.00	3	0	0	0	-94.2	RQT
5 MHz	100%	50% Abs.	-151	3	10	30	13.1	3	30.0	65.9	300.0	1.3	0	300.0	85.9	750	0.5	0	750	93.8	65.8	3.00	3	0	0	0	-94.2	RQT
20 MHz	100%	50% Abs.	-149.5	3	10	30	13.1	3	30.0	65.9	300.0	1.3	0	300.0	85.9	750	0.5	0	750	93.8	65.8	3.00	3	0	0	0	-92.7	RQT
100 kHz	100%	OOK	-112	3	10	30	13.1	3	30.0	65.9	300.0	1.3	0	300.0	85.9	750	0.5	0	750	93.8	65.8	3.00	3	0	0	0	-55.2	DNBL
20 MHz	100%	OOK	-137	3	10	30	13.1	3	30.0	65.9	300.0	1.3	0	300.0	85.9	750	0.5	0	750	93.8	65.8	3.00	3	0	0	0	-80.2	BL
100 kHz	100%	2% Rel.	-119	3	10	30	13.1	3	30.0	65.9	300.0	1.3	0	300.0	85.9	750	0.5	0	750	93.8	65.8	3.00	3	0	0	0	-62.2	RQT
1 MHz	100%	2% Rel.	-149	3	10	30	13.1	3	30.0	65.9	300.0	1.3	0	300.0	85.9	750	0.5	0	750	93.8	65.8	3.00	3	0	0	0	-92.2	RQT
5 MHz	100%	2% Rel.	-149	3	10	30	13.1	3	30.0	65.9	300.0	1.3	0	300.0	85.9	750	0.5	0	750	93.8	65.8	3.00	3	0	0	0	-92.2	RQT
20 MHz	100%	2% Rel.	-149.5	3	10	30	13.1	3	30.0	65.9	300.0	1.3	0	300.0	85.9	750	0.5	0	750	93.8	65.8	3.00	3	0	0	0	-92.7	RQT
100 kHz	20%	None	-116.5	3	10	30	13.1	3	30.0	65.9	300.0	1.3	0	300.0	85.9	750	0.5	0	750	93.8	65.8	3.00	3	0	0	0	-59.7	DNBL
20 MHz	20%	None	-148	3	10	30	13.1	3	30.0	65.9	300.0	1.3	0	300.0	85.9	750	0.5	0	750	93.8	65.8	3.00	3	0	0	0	-91.2	BL
100 kHz	20%	50% Abs.	-116	3	10	30	13.1	3	30.0	65.9	300.0	1.3	0	300.0	85.9	750	0.5	0	750	93.8	65.8	3.00	3	0	0	0	-59.2	DNBL
1 MHz	20%	50% Abs.	-132	3	10	30	13.1	3	30.0	65.9	300.0	1.3	0	300.0	85.9	750	0.5	0	750	93.8	65.8	3.00	3	0	0	0	-75.2	RQT
5 MHz	20%	50% Abs.	-151	3	10	30	13.1	3	30.0	65.9	300.0	1.3	0	300.0	85.9	750	0.5	0	750	93.8	65.8	3.00	3	0	0	0	-94.2	RQT
20 MHz	20%	50% Abs.	-148	3	10	30	13.1	3	30.0	65.9	300.0	1.3	0	300.0	85.9	750	0.5	0	750	93.8	65.8	3.00	3	0	0	0	-91.2	RQT
100 kHz	20%	OOK	-118.5	3	10	30	13.1	3	30.0	65.9	300.0	1.3	0	300.0	85.9	750	0.5	0	750	93.8	65.8	3.00	3	0	0	0	-61.7	DNBL
20 MHz	20%	OOK	-146	3	10	30	13.1	3	30.0	65.9	300.0	1.3	0	300.0	85.9	750	0.5	0	750	93.8	65.8	3.00	3	0	0	0	-89.2	BL
100 kHz	20%	2% Rel.	-138	3	10	30	13.1	3	30.0	65.9	300.0	1.3	0	300.0	85.9	750	0.5	0	750	93.8	65.8	3.00	3	0	0	0	-81.2	RQT
1 MHz	20%	2% Rel.	-134	3	10	30	13.1	3	30.0	65.9	300.0	1.3	0	300.0	85.9	750	0.5	0	750	93.8	65.8	3.00	3	0	0	0	-77.2	RQT
5 MHz	20%	2% Rel.	-142.5	3	10	30	13.1	3	30.0	65.9	300.0	1.3	0	300.0	85.9	750	0.5	0	750	93.8	65.8	3.00	3	0	0	0	-85.7	RQT
20 MHz	20%	2% Rel.	-143.5	3	10	30	13.1	3	30.0	65.9	300.0	1.3	0	300.0	85.9	750	0.5	0	750	93.8	65.8	3.00	3	0	0	0	-86.7	RQT

BL Break-lock

RQT - Reacquisition Time

DNBL - Did not break lock at the maximum UWB generator signal power

**Operational Scenario: Aviation GPS Receiver Non-Precision Approach  
and Multiple UWB Devices**

**GPS Receiver Architecture: C/A-code**

Broadband Noise			Imax (dBW/MHz)	Hgps (m)	Huwb (m)	Gr (dBic)	Dmin (m)	Lp (dB)	Lmult (dB)	Lallot (dB)	Lman (dB)	Laf (dB)	Lba (dB)	Lsm (dB)	UWB EIRP (dBW/MHz)	GPS Receiver Criteria
Broadband Noise			-134.5	41.4	3	-10	41.4	68.7	6	10	3	0	0	6	-80.8	RQT
UWB PRF	UWB Gating	UWB Mod.	Imax (dBW)	Hgps (m)	Huwb (m)	Gr (dBic)	Dmin (m)	Lp (dB)	Lmult (dB)	Lallot (dB)	Lman (dB)	Laf (dB)	Lba (dB)	Lsm (dB)	UWB EIRP (dBW)	GPS Receiver Criteria
1 MHz	100%	None	-143.7	41.4	3	-10	41.4	68.7	0	10	3	0	0	6	-84.0	BL
5 MHz	100%	None	-145.5	41.4	3	-10	41.4	68.7	0	10	3	0	0	6	-85.8	BL
20 MHz	100%	None	-145	41.4	3	-10	41.4	68.7	0	10	3	0	0	6	-85.3	BL
5 MHz	20%	None	-145.2	41.4	3	-10	41.4	68.7	0	10	3	0	0	6	-85.5	BL
20 MHz	20%	None	-145.8	41.4	3	-10	41.4	68.7	0	10	3	0	0	6	-86.1	BL
5 MHz	100%	OOK	-144.5	41.4	3	-10	41.4	68.7	0	10	3	0	0	6	-84.8	BL
20 MHz	100%	OOK	-144.5	41.4	3	-10	41.4	68.7	0	10	3	0	0	6	-84.8	BL
5 MHz	20%	OOK	-144.2	41.4	3	-10	41.4	68.7	0	10	3	0	0	6	-84.5	BL
20 MHz	20%	OOK	-146.3	41.4	3	-10	41.4	68.7	0	10	3	0	0	6	-86.6	BL
UWB PRF	UWB Gating	UWB Mod.	Imax (dBW)	Hgps (m)	Huwb (m)	Gr (dBic)	Dmin (m)	Lp (dB)	Lmult (dB)	Lallot (dB)	Lman (dB)	Laf (dB)	Lba (dB)	Lsm (dB)	UWB EIRP (dBW/MHz)	GPS Receiver Criteria
100 kHz	100%	None	-112.6	41.4	3	-10	41.4	68.7	0	10	3	0	0	6	-52.9	BL
100 kHz	20%	None	-106.5	41.4	3	-10	41.4	68.7	0	10	3	0	0	6	-46.8	DNBL
1 MHz	20%	None	-134.5	41.4	3	-10	41.4	68.7	6	10	3	0	0	6	-80.8	NRQT
100 kHz	100%	OOK	-102.6	41.4	3	-10	41.4	68.7	0	10	3	0	0	6	-42.9	DNBL
1 MHz	100%	OOK	-134.5	41.4	3	-10	41.4	68.7	6	10	3	0	0	6	-80.8	NRQT
100 kHz	20%	OOK	-109.4	41.4	3	-10	41.4	68.7	0	10	3	0	0	6	-49.7	DNBL
1 MHz	20%	OOK	-134.5	41.4	3	-10	41.4	68.7	6	10	3	0	0	6	-80.8	NRQT
100 kHz	100%	50% Abs.	-100	41.4	3	-10	41.4	68.7	0	10	3	0	0	6	-40.3	DNBL
1 MHz	100%	50% Abs.	-134.5	41.4	3	-10	41.4	68.7	6	10	3	0	0	6	-80.8	NRQT
5 MHz	100%	50% Abs.	-137	41.4	3	-10	41.4	68.7	6	10	3	0	0	6	-83.3	RQT
20 MHz	100%	50% Abs.	-138	41.4	3	-10	41.4	68.7	6	10	3	0	0	6	-84.3	RQT
100 kHz	100%	2% Rel.	-100	41.4	3	-10	41.4	68.7	0	10	3	0	0	6	-40.3	DNBL
1 MHz	100%	2% Rel.	-134.5	41.4	3	-10	41.4	68.7	6	10	3	0	0	6	-80.8	NRQT
5 MHz	100%	2% Rel.	-136.5	41.4	3	-10	41.4	68.7	6	10	3	0	0	6	-82.8	RQT
20 MHz	100%	2% Rel.	-136	41.4	3	-10	41.4	68.7	6	10	3	0	0	6	-82.3	RQT
100 kHz	20%	50% Abs.	-107	41.4	3	-10	41.4	68.7	0	10	3	0	0	6	-47.3	DNBL
1 MHz	20%	50% Abs.	-134.5	41.4	3	-10	41.4	68.7	6	10	3	0	0	6	-80.8	NRQT
5 MHz	20%	50% Abs.	-134.5	41.4	3	-10	41.4	68.7	6	10	3	0	0	6	-80.8	NRQT
20 MHz	20%	50% Abs.	-134.5	41.4	3	-10	41.4	68.7	6	10	3	0	0	6	-80.8	NRQT
100 kHz	20%	2% Rel.	-107	41.4	3	-10	41.4	68.7	0	10	3	0	0	6	-47.3	DNBL
1 MHz	20%	2% Rel.	-134.5	41.4	3	-10	41.4	68.7	6	10	3	0	0	6	-80.8	NRQT
5 MHz	20%	2% Rel.	-134.5	41.4	3	-10	41.4	68.7	6	10	3	0	0	6	-80.8	NRQT
20 MHz	20%	2% Rel.	-134.5	41.4	3	-10	41.4	68.7	6	10	3	0	0	6	-80.8	NRQT

BL - Break-lock

RQT - Reacquisition Time

DNBL - Did not break lock at the maximum UWB generator signal power

NRQT - Broadband Noise Reacquisition

	A	B	C	D	E	F	G	H	I	J	K	L	M	N	O
1	Transmitter			Path Loss	Continental Temperat			Okumura	Receive Antenna	Const	OMNI				
2	<b>uV/m/MHz @ R(m)</b>			Free Space	Flat				bw(deg)	Gain(dBi)		Beamwidth		<input checked="" type="radio"/> V <input type="radio"/> H	
3	500	3	<input checked="" type="radio"/> field st	Tirem & ITM					515.74	-10		horiz/conical	60	back lobe	elev(deg)
4	-41.278	-40	<input type="radio"/> EIRP	Average Ground	10%,50%,50				180	-0.857		vertical			<input type="checkbox"/> back lobe
5	FREQ	1575.42		General	Mode	Parameterize			h(km)	NF(dB)	System Losses	Smin(dBm)	I other(dBm/MHz)	Ring Spacing	
6	RIN	0	<input checked="" type="radio"/> maxvis	Calculate	EIRP[I/N]	Altitude				3	-10			10 meter	
7	ROUT	20	<input type="radio"/> ROUT	<input checked="" type="checkbox"/> Lagg+Lsingle	6.17723	-69.752	0		3	-110.98	dB	0.15	<input type="checkbox"/> I other		<input type="checkbox"/> Make trace file?
8				Criteria(dB)	MxSnalEirp	@R(km)			tranht(m)	N(dBm/MHz)		Bc(MHz)			<input type="checkbox"/> Radar Altimeter
9															
10															
11															
12															
13															
14															
15															
16															
17															
18															
19															
20															
21															
22															
23															
24			<input checked="" type="radio"/>												
25			<input type="radio"/>												
26			<input type="radio"/>												
27			<input type="radio"/>												
28			<input type="radio"/>												
29															
30															

Operational Scenario: En-route Navigation and indoor UWB Device Operation

Active Emitters/km <sup>2</sup>	MAX EIRP (dBW/MHz)
1	-55
10	-65
100	-75
1000	-85
10000	-95

	0.03	0.1	0.1	0.3048		
<input checked="" type="radio"/>	1	-69.882	-59.962	-59.962	-53.651	-104.8
<input type="radio"/>	10	-70.9	-64.096	-64.096	-63.651	6.17723
<input type="radio"/>	200	-77.569	-77.107	-77.107	-76.661	
<input type="radio"/>	1000	-84.558	-84.096	-84.096	-83.651	
<input type="radio"/>	10000	-94.558	-94.096	-94.096	-93.651	

	A	B	C	D	E	F	G	H	I	J	K	L	M	N	O
1	Transmitter			Path Loss	Continental Temperature			Okumura	Receive Antenna	Const	OMNI			V	H
2	<b>uV/m/MHz @ R(m)</b>			Free Space	Flat				<b>bw(deg)</b>	<b>Gain(dBi)</b>		Beamwidth			
3	500	3	<input checked="" type="radio"/> field st	Tirem & ITM	10%,50%,50%				515.74	-10	<input checked="" type="radio"/>	horiz/conical	60	back lobe	elev(deg)
4	-41.278	-40	<input type="radio"/> EIRP	Average Ground					180	-0.857	<input type="radio"/>	vertical			back lobe
5	<b>FREQ</b>	<b>1575.42</b>		General	Mode	Parameterize			h(km)	NF(dB)	System Losses	Smin(dBm)	I other(dBm/MHz)		Ring Spacing
6	<b>RIN</b>	<b>0</b>	<input checked="" type="radio"/> maxvis	<b>Calculate</b>	EIRP[I/N]	Altitude				3	-19				10 meter
7	<b>ROUT</b>	<b>20</b>	<input type="radio"/> ROUT	<input checked="" type="checkbox"/> Lagged + Isingle	<b>6.17723</b>	<b>-78.752</b>	<b>0</b>		<b>3</b>	<b>-110.98</b>	dB	<b>0.15</b>	<input type="checkbox"/> I other		Make trace file?
8					Criteria(dB)	MxSnglEirp	@R(km)	tranht(m)	N(dBm/MHz)			Bf(MHz)			Make trace file?
9															Make trace file?
10															Make trace file?
11															Make trace file?
12															Make trace file?
13															Make trace file?
14															Make trace file?
15															Make trace file?
16															Make trace file?
17															Make trace file?
18															Make trace file?
19															Make trace file?
20															Make trace file?
21															Make trace file?
22															Make trace file?
23															Make trace file?
24															Make trace file?
25															Make trace file?
26															Make trace file?
27															Make trace file?
28															Make trace file?
29															Make trace file?
30															Make trace file?

Operational Scenario: En-route Navigation and outdoor UWB Device Operation

Active Emitters/km <sup>2</sup>	MAX EIRP (dBW/MHz)
1	-62.651
10	-72.651
100	-82.651
1000	-92.651
10000	-102.651

	0.03	0.1	0.1	0.3048	
<input checked="" type="radio"/>	1	-78.882	-68.962	-68.962	-62.651
<input type="radio"/>	10	-79.9	-73.096	-73.096	-72.651
<input type="radio"/>	200	-86.569	-86.107	-86.107	-85.661
<input type="radio"/>	1000	-93.558	-93.096	-93.096	-92.651
<input type="radio"/>	10000	-103.56	-103.1	-103.1	-102.65